



Thermo Scientific APEX 100
Metal Detector

- Sensitive with low false rejects
- Robust and reliable
- Dual frequency and gain

economical metal protection for conveyor and gravity applications

The Thermo Scientific APEX 100 provides cost-effective protection from metal contaminants keeping your brand safe. It is based on industry-leading APEX technology.

Thermo Scientific APEX 100

General Specifications

Construction	Stainless steel 304 straightlined case, ABS plastic control panel
Protection Ratings	IP69K, Type 3 enclosure, ATEX zone 22, hazardous location Class II Division 2 Groups F&G
Operating Temperature	-10°C to +40°C (+14°F to +104°F)
Relative Humidity	20% to 80% non-condensing
Electrical Supply	85 volts to 260 volts AC single phase plus earth ground; 47 Hz to 65 Hz, 100 watts maximum
Air Supply (for AuditCheck)	5.5 bar (80 psi)
Product Speed	0.5 m/min (1.7 ft/min) to 1000 m/min (3,300 ft/min)
Outputs	6 Relays outputs; Relays: 250 volt AC 2 amp max. 50 volt DC 1 amp max.
Output Allocation (selectable via menu)	Reject 1, Reject 2, AuditCheck, Fault, Alarm, Warning, QA Lamp
Inputs	6 Inputs - Active 12v DC+12 volt auxiliary supply for input sensors
Input Allocation (selectable via menu)	Speed Sensor, Keylock, Product Select 1, Product Select 2, Infeed PEC, Reject Confirmation 1 and Bin Full, External Suppression, External Alarm, External Reset
Communications	Optional ModBus serial or Ethernet modules
Safety and Export Approvals	cCSAus, CE, ATEX zone 22
Manufacturing Quality	ISO9001 certified
Help-Text, Users Manual Languages	English, Spanish, French, German, Italian, Dutch, Chinese, Czech, Russian, Polish, Thai, Koren and Brazilian Portuguese

APEX 100 Metal Detector Dimensional Diagram for Conveyor Applications

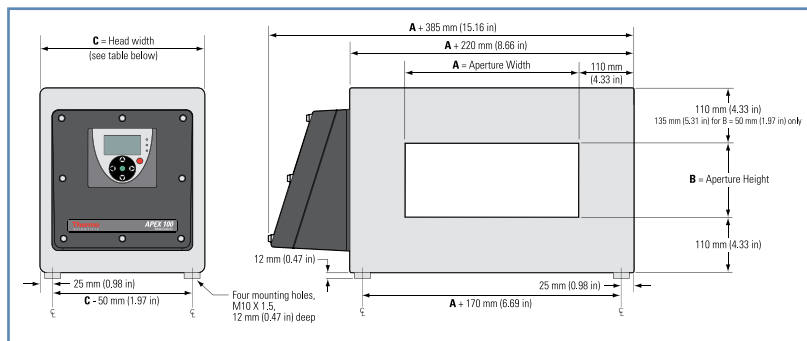

APEX 100 Metal Detector Dimensional Diagram for Drop Through Applications

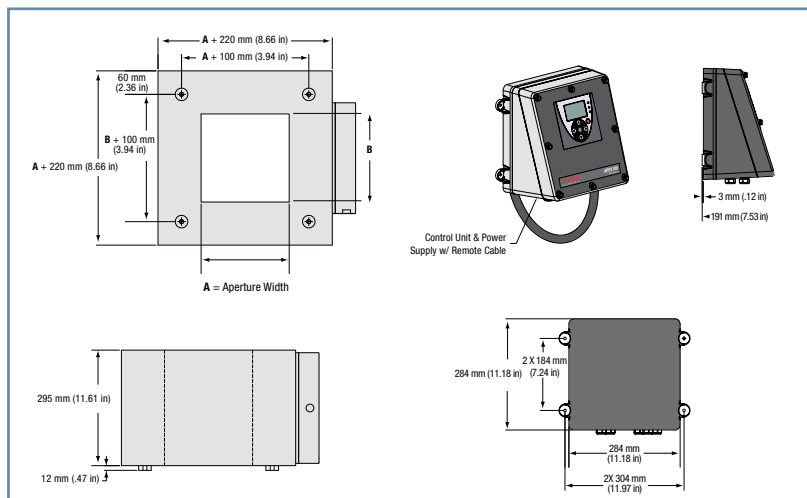

Features & Benefits

- Sensitivity matching the legacy Thermo Scientific™ DSP 3 and Metal Eliminator detectors
- Compact and robust mechanical design makes installation easy and provides for years of reliable operation
- Unique icon driven interface with multilingual Help and Autocalibrate functions
- Dual frequency /dual gain operation for application flexibility
- Available with Thermo Scientific conveyor and drop through systems designed to your specifications
- Optional Modbus serial or Ethernet communications

The Thermo Scientific APEX 100 metal detector provides protection from many types of metal contaminants encountered in food production today. It offers basic magnetics, electronics and software technology developed for the high performance Thermo Scientific APEX 500 metal detector. By offering only the most commonly required metal detection capabilities, the APEX 100 delivers outstanding value.

APEX Head Width

Smallest Aperture Dimension (A or B)	Head Width (C)
50 mm (1.97 in) to 200 mm (7.87 in)	295 mm (11.61 in)
* 225 mm (8.9 in)	295 mm (11.61 in)
250 mm (9.84 in) to 300 mm (11.51 in)	330 mm (12.99 in)
350 mm (13.75 in) to 450 mm (17.72 in)	380 mm (14.96 in)
500 mm (19.69 in) to 600 mm (23.62 in)	480 mm (18.90 in)

* Only available for drop through applications

www.thermoscientific.com/apex

© 2013 Thermo Fisher Scientific Inc. All rights reserved. All trademarks are the property of Thermo Fisher Scientific Inc. and its subsidiaries. Specifications, terms and pricing are subject to change. Not all products are available in all countries. Please consult your local sales representative for details.

US and Canada 800 227 8891
Asia/Australia 800 445 3503
Mexico +52 55 5639 2184
Argentina +54 11 4334 3827
Chile +56 22 2378 5080

India +91 22 4157 8800
Italy +39 0 5217 8861
France +33 (0) 16 092 4800
Germany +49 (0) 20 882 4930
Spain +34 (0) 91 484 5965

UK +44 (0) 17 8882 0300
Netherlands +31 (0) 76 579 5555
South Africa +27 11 776 0000
China 800 810 5118

Thermo
 SCIENTIFIC

Part of Thermo Fisher Scientific

Email: sales.packaging.us@thermofisher.com

Literature Code PI.0048.0114