

Serial Communications Manual

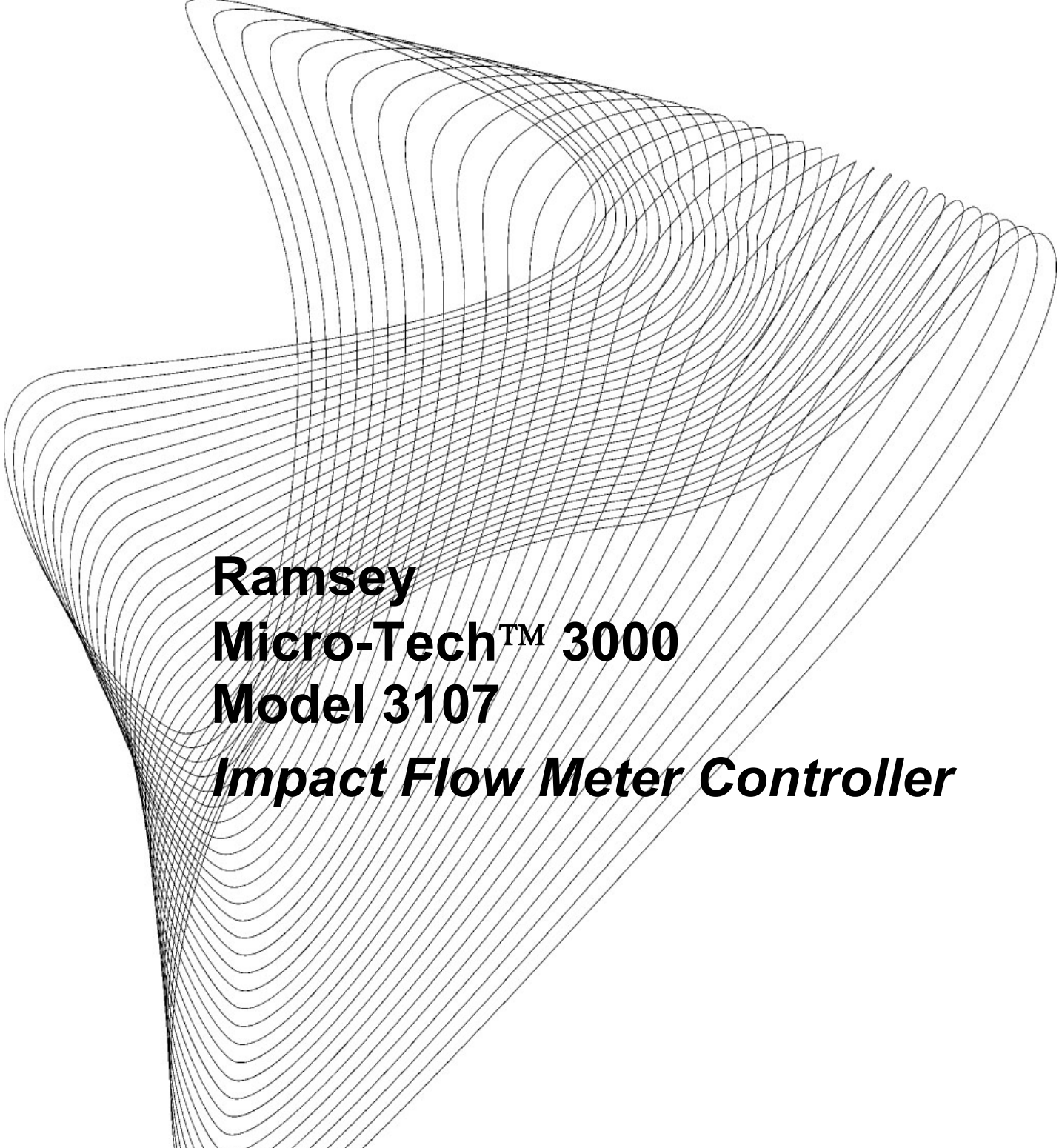

Ramsey
Micro-Tech™ 3000
Model 3107
Impact Flow Meter Controller

Serial Comm-
3107 Rev
Part No.: XXXXX

Thermo
ELECTRON CORPORATION

Ramsey
Micro-Tech™ 3000
Serial Communications
Model 3107
Impact Flow Meter Controller

This document is confidential and is the property of *Thermo Electron*. It may not be copied or reproduced in any way without the express written consent of *Thermo Electron*. This document also is an unpublished work of *Thermo Electron*. *Thermo Electron* intends to, and is maintaining the work as confidential information. *Thermo Electron* also may seek to protect this work as an unpublished copyright. In the event of either inadvertent or deliberate publication, *Thermo Electron* intends to enforce its rights to this work under the copyright laws as a published work. Those having access to this work may not copy, use, or disclose the information in this work unless expressly authorized by *Thermo Electron*.

All registered and unregistered trademarks are the property of their respective owners.



Thermo Electron,
501 90th Avenue N.W.
Minneapolis, MN 55433 U.S.A.
Tel (763) 783-2500
Fax (763) 783-2525
<http://www.thermoelectron.com>
eng@thermoelectron.com
2003 Thermo Electron

Thermo
ELECTRON CORPORATION

Revision History

Preliminary December 2003 Manual first released

Table of Contents

Table of Contents	i
List of Figures	iii
List of Tables	iv
Chapter 1 Introduction	1-1
1.1 General.....	1-1
1.2 Communication Protocols.....	1-1
1.2.1 Protocol Rules	1-2
1.3 Printer.....	1-3
1.4 Thermo Electron Warranty.....	1-3
Disclaimer.....	1-4
Chapter 2 Installation.....	2-1
2.1 General.....	2-1
2.2 Comm A Board (Option) Installation.....	2-1
2.3 Communication Configuration (Mother Board) COMM1	2-6
Chapter 3 Operation	3-1
3.1 General.....	3-1
3.2 Print Key.....	3-1
3.3 Print Formats.....	3-2
3.3.1 Totals	3-2
3.3.2 Batch	3-3
3.3.3 Alarms	3-3
3.3.4 Set Up	3-3
3.3.5 Audit Trails	3-3
3.4 Communication Set-Up.....	3-4
3.4.1 Clock/Calendar Set-Up.....	3-4
3.4.2 COMM A and Print Scroll Set-Up	3-5
3.4.3 Multidrop Operator Set-Up	3-8
3.4.4 Printer Set-Up	3-9
3.4.5 Define Printing Format.....	3-11
3.4.6 Setting the Printer Inhibit Range	3-12
3.4.7 Additional Diagnostic	3-12
3.5 Communication Protocols.....	3-13
3.5.1 Register Definition	3-13
3.6 PC-Master	3-25
3.6.1 Description	3-25
3.6.2 Register Mapping for PC-Master Protocol	3-29
3.7 Siemens 3964R.....	3-32
3.7.1 Description	3-32
3.7.2 Register Mapping for Siemens 3964R Protocol.....	3-35
3.8 Modbus.....	3-39

Serial Communications 3107

3.8.1	Description	3-39
3.8.2	Register Mapping for Modbus	3-42
3.9	Allen-Bradley DF1 (PLC-5)	3-46
3.9.1	Description	3-46
3.9.2	Register Mapping for DF1 Allen-Bradley (PLC-5).....	3-52
Chapter 4	Maintenance	4-1
4.1	General.....	4-1
Chapter 5	Parts.....	5-1
5.1	General.....	5-1

List of Figures

Figure 2-1	COMM A Board	2-2
Figure 2-2	Micro-Tech 3000 Mother Board	2-3
Figure 2-3	Serial Connection RS232	2-4
Figure 2-4	Serial Connection RS485	2-5
Figure 2-5	Mother Board Area of Detail	2-8

List of Tables

Table 2-1:	COMM A Board Jumpers	2-1
Table 2-2:	Mother Board COMM1 Communications Wiring Config. TB3–RS485	2-6
Table 2-3:	Mother Board Wiring Configuration TB3-RS232 Communications	2-6
Table 2-4:	Mother Board Wiring Configuration TB3-20mA Serial Communications	2-7
Table 2-5:	Mother Board Communication Jumper Setting	2-7

Chapter 1 Introduction

1.1 General

The Micro-Tech 3000 Integrator is a bus-based microprocessor instrument equipped with one COMM A (on Mother Board) that can be equipped (optionally) with a second serial communication boards. Each COMM A board has one serial channel that can be configured according to the following standards.

- RS423/RS232C For point to point asynchronous bidirectional communications, maximum 50 feet (15 m). Modem capability.
- RS485/RS422 For point to point or multidrop 4 wire bidirectional communications, maximum 4000 feet (1200 m).
- Current Loop For high immunity bidirectional asynchronous communications. Passive only.

All of the above are optically isolated.

COMM A board (Optionally) can be installed in any available mother board expansion slot. After installing the board and power has been restored, the instrument automatically detects the new board and adds the communication set-up scrolls to the Main Menu scrolls. The Micro-Tech refers to the COMM A on the Mother Board as COM 1, and the COMM A board (if installed) as COM 2.

If two COMM A are available; one can be set up for printing, the other one for transferring data to and from other intelligent devices such as computers and PLC's. The system cannot support two printers or two COMM lines.

Each COMM A contains a perpetual clock/calendar circuit with battery backup. The battery is located on the mother board and is the same battery used for system memory backup. The system automatically detects and uses the clock calendar circuit of the first board and ignores the second.

Time and date set-up screens become visible after the COMM board is installed.

The Micro-Tech 3000 Integrator COMM meets the year 2000 requirements.

1.2 Communication Protocols

When a COMM line is set up for communication (not for a printer), the system is able to send and receive data to and from another device connected to the COMM line. The COMM option comes with the following software communication protocols already built in:

- PC-Master A Thermo Ramsey proprietary protocol, multidrop.
- Modbus An AEG proprietary protocol, multidrop. The COMM option only contains a subset of the protocol as specified in this manual.
- Allen-Bradley A proprietary protocol, multidrop. The COMM option only contains a subset of the protocol in the PLC-5 version of it, as specified in this manual.
- 3964R A Siemens proprietary protocol, single point.

The hardware can be configured (through jumpers on the Mother Board and on the optionally COMM board if available) to one of the three standards as listed in the previous paragraph. However, only the RS485/RS422 standard allows multidrop communications, RS232C and Current Loop can only be used in point to point mode. This does not prevent the use of a protocol; it only prevents physically connecting the Micro-Tech 3000 to more than one device.

CAUTION

The communication protocols have been implemented and tested as described in this document or in other referenced documents. It is the intention of Thermo Ramsey to provide all the necessary information and help the user to connect the instrument to other compatible devices. However, because most of the protocols are specific to other manufacturers, Thermo Ramsey declines any responsibility for any malfunction that may occur when connecting the instrument to devices of other manufacturers, unless tested and approved by Thermo Ramsey.

1.2.1 Protocol Rules

The communication protocol allows a remote intelligent device to read and eventually write information from and to the Micro-Tech 3000. For convenience, the information is organized in a set of registers as listed in this document.

During the communication activity, the Micro-Tech 3000 always acts as Slave, meaning it responds to a request from a Master device on the line, but never attempts to send messages out.

The following rules apply:

- a. The Micro-Tech 3000 responds only if the message is completely received.
- b. The Micro-Tech 3000 reads the message and looks for the address, which is contained into an address byte in the query package. The message is then processed only if the address matches the one specified in the set-up data of the Micro-Tech 3000, otherwise it is ignored.
- c. When the system receives a message, the integrity of the message is checked. An answer-back message is prepared if the message is formally correct.
- d. When a message containing a variable to be written in memory is received, the system checks the correctness of the message and, if it is correct, immediately sends the answer-back message. This does not always mean the data is written in memory. The system first checks the register number (which must correspond to a valid address of a variable), then the minimum and maximum limits, and then the password. If data can be accepted, it is stored in memory and the success flag is set to 0 (no error). If not, it is set to 1. To know if the last variables sent have been stored, the Master checks (reads) the success flag contained in a read only register.

The following procedure applies:

- The Host sends data to the Micro-Tech 3000.

- The Host waits at least 100 ms.
- The Host reads the success flag. It should be 0.

Some data is read only, some is read write, and some is write only.

WARNING

In all cases, the maximum number of words the system can transfer is limited to 41 per time. Requests of registers in excess of 41 are considered errors and do not generate an answer.

1.3 Printer

When a COMM line is set up for printing, the system prints out data in different ways, depending on the set-up. Print menus become visible that allow the user to define when and in which format the data is printed.

1. Periodical printouts at predefined intervals, as well as at predefined times of day, or on command is possible.
2. The format of the printouts is selectable between a number of predefined formats, plus a fully programmable user defined format. In this particular case, the user is able to easily format the printout to fit into any pre-printed ticket or form, without the need of special software.

1.4 Thermo Electron Warranty

The seller agrees, represents, and warrants that the equipment delivered hereunder shall be free from defects in material and workmanship. Such warranty shall not apply to accessories, parts, or material purchased by the seller unless they are manufactured pursuant to seller's design, but shall apply to the workmanship incorporated in the installation of such items in the complete equipment. To the extent purchased parts or accessories are covered by the manufacturer's warranty, seller shall extend such warranty to buyer.

Seller's obligation under said warranty is conditioned upon the return of the defective equipment, transportation charges prepaid, to the seller's factory in Minneapolis, Minnesota, and the submission of reasonable proof to seller prior to return of the equipment that the defect is due to a matter embraced within seller's warranty hereunder. Any such defect in material and workmanship shall be presented to seller as soon as such alleged errors or defects are discovered by purchaser and seller is given opportunity to investigate and correct alleged errors or defects and in all cases, buyer must have notified seller thereof within one (1) year after delivery, or one (1) year after installation if the installation was accomplished by the seller.

Said warranty shall not apply if the equipment shall not have been operated and maintained in accordance with seller's written instructions applicable to such equipment, or if such equipment shall have been repaired or altered or modified without seller's approval; provided, however, that the foregoing limitation of warranty insofar as it relates to repairs, alterations, or modifications, shall not be applicable to routine preventive and corrective maintenance which normally occur in the operation of the equipment.

"EXCEPT FOR THOSE WARRANTIES SPECIFICALLY CONTAINED HEREIN,

SELLER DISCLAIMS ANY AND ALL WARRANTIES WITH RESPECT TO THE EQUIPMENT DELIVERED HEREUNDER, INCLUDING THE IMPLIED WARRANTIES OF MERCHANTABILITY AND FITNESS FOR USE. THE SOLE LIABILITY OF SELLER ARISING OUT OF THE WARRANTY CONTAINED HEREIN SHALL BE EXCLUSIVELY LIMITED TO BREACH OF THOSE WARRANTIES. THE SOLE AND EXCLUSIVE REMEDY FOR BREACH OF THE WARRANTIES SET OUT ABOVE SHALL BE LIMITED TO THE REPAIR OR REPLACEMENT OF ANY DEFECTIVE ACCESSORY, PART OR MATERIAL WITH A SIMILAR ITEM FREE FROM DEFECT, AND THE CORRECTION OF ANY DEFECT IN WORKMANSHIP. IN NO EVENT SHALL SELLER BE LIABLE FOR ANY INCIDENTAL OR CONSEQUENTIAL DAMAGES.”

Purchaser agrees to underwrite the cost of any labor required for replacement; including time, travel, and living expenses of *Thermo Electron Field Service* Engineer at closest factory base.

THERMO ELECTRON
501 90TH AVE. NW
MINNEAPOLIS, MN 55433
PHONE: (763) 783-2500
FAX: (763) 783-2525

Disclaimer

Though the information provided herein is believed to be accurate, be advised that the information contained herein is *not* a guarantee for satisfactory results. Specifically, this information is neither a warranty nor guarantee, expressed or implied, regarding performance, merchantability, fitness, or any other matter with respect to the products, and recommendation for use of the product/process information in conflict with any patent. Please note that *Thermo Electron* reserves the right to change and/or improve the product design and specifications without notice.

Chapter 2 Installation

2.1 General

This chapter describes the installation procedure and hardware configuration for the communications (on Mother Board and on Comm A Board option). If the communication option was installed at the factory, it may not be necessary to continue with this chapter. Proceed to Chapter 3.0, Operation.

2.2 Comm A Board (Option) Installation

To install the COMM A board, proceed as follows:

1. Select the jumper positions on the COMM A board for the desired communication standard. Below is a table which summarizes the jumper positions for selection of the electrical interface. Refer to Figure 2-1 for jumper locations.

**TABLE 2-1
COMM A BOARD JUMPERS**

JUMPERS						
Mode	OP1	OP2	OP3	OP4	OP5	OP6
RS-232	"A"	"A"	"A"	"A"	"A"	"B"
RS-485	"B"	"A"	"B"	"B"	"MDP"	"TRM"
20 mA	"B"	"B"	"A"	"A"	"A"	"C"

[Default]

TABLE "MDP"
FOR RS-485 ONLY

OP5
"A" NORMAL
"B" MULTIDROP

TABLE "TRM"
FOR RS-485 ONLY

OP6
"A" TERMINATED
"B" NOT TERMINATED

2. Open the Micro-Tech wall mount enclosure and turn power off at the mains, or remove panel mount enclosure from the panel and remove top cover allowing access to the mother board.
3. Remove the field mating connector. Wire the connector per the supplied field wiring diagram or install field terminal board cable (wall mount only).
4. Remove the hex head mounting screw from the connector end of the COMM board.
5. Insert the COMM board in any available expansion slot on the mother board (see Figure 2-2).

Figure 2-2 Micro-Tech 3000 Mother Board

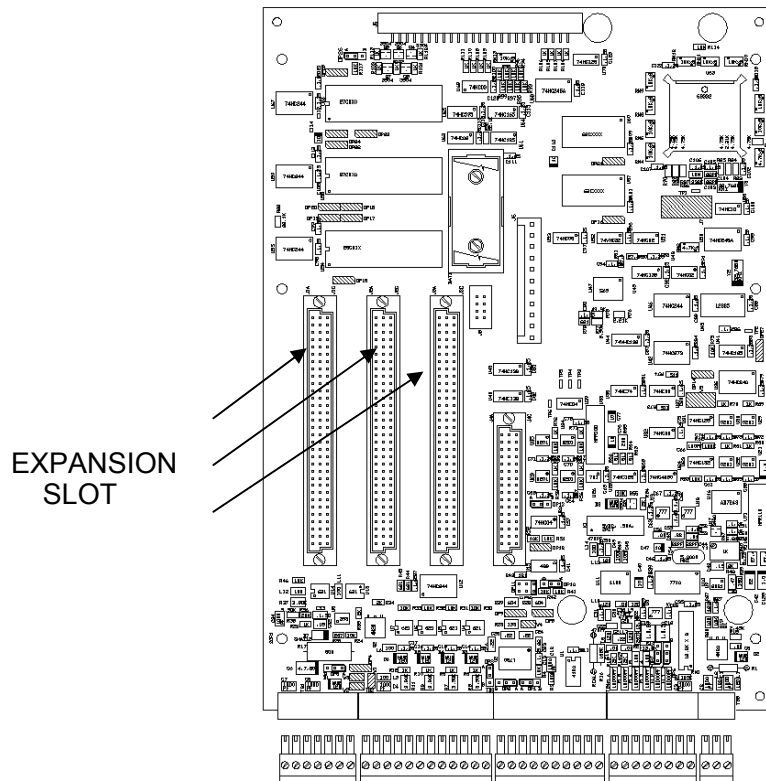

6. Insert the hex head screw through the chassis and tighten.
7. Install the wired mating connector on the COMM board connector.
8. Reinstall panel mount enclosure in the panel.
9. Turn power back on. The following screen appears when power is applied and remains on for 10 seconds.

-SLOT # N CHANGED
Acquire new
configuration?
YES NO

The screen disappears after 10 seconds if the question is not answered, and the Micro-Tech 3000 assumes the answer is NO. "HW CONFIG. CHANGED" alarm is on and cannot be reset. The above screen appears each time power is cycled if the question is not answered.

Answer YES because this is a hardware configuration change.

10. This completes the installation procedure.
11. Set-up data for the newly installed COMM board must now be entered. Proceed to Chapter 3.0, Operation.

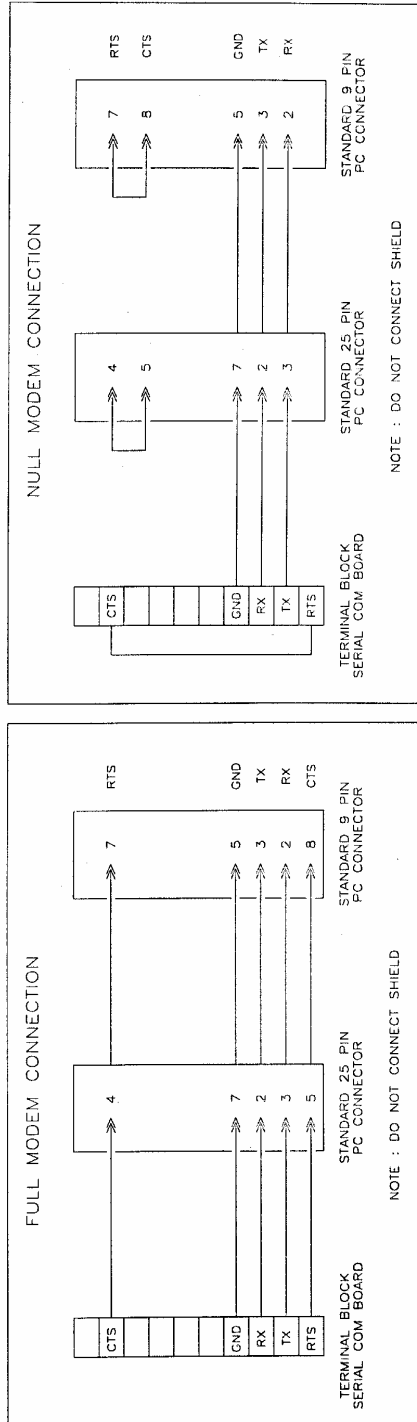

Figure 2-3 Serial Connection RS232

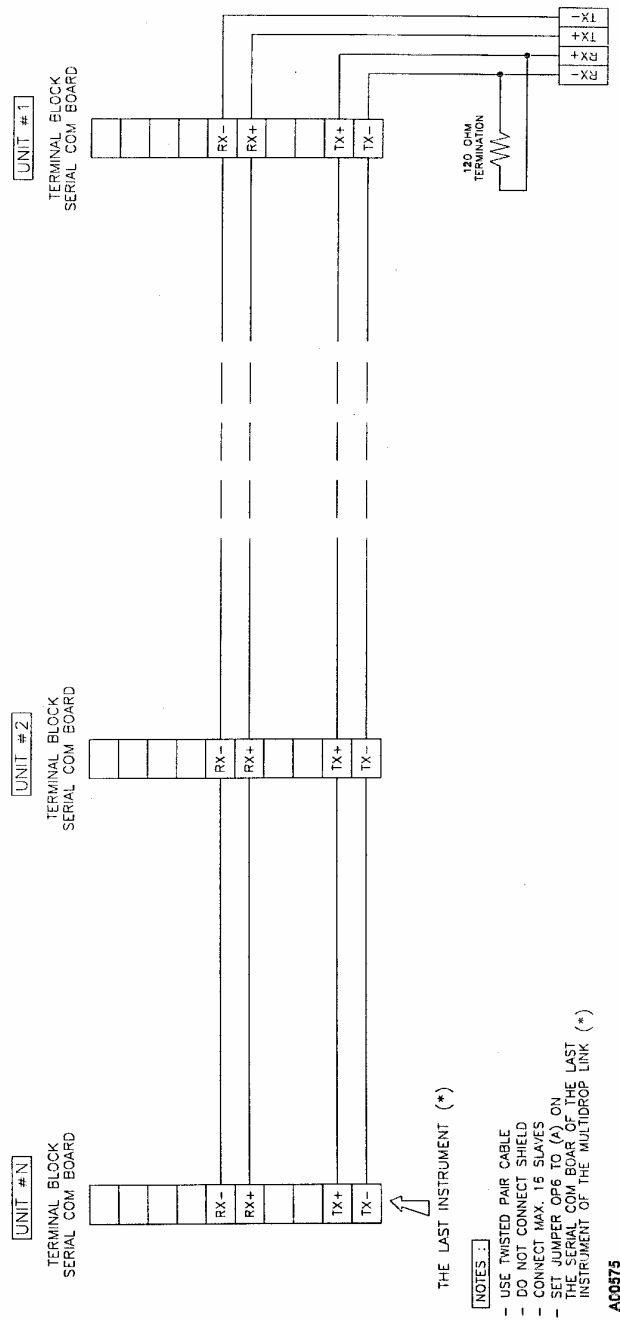

Figure 2-4 Serial Connection RS485

2.3 Communication Configuration (Mother Board) COMM1

This section describes the setup procedure and hardware configuration for the communications from the motherboard. Use the following steps to configure the communications:

Select the jumper positions for the desired communication standard. Refer to Table 2-5 for jumper locations.

Wire to the *Terminal Block 3* on the motherboard for the communication standard selected, *RS-485*, *RS-232c*, *20 mA* current loop.

Table 2-2: Mother Board COMM 1 Communications Wiring Configuration - TB3 – RS-485

Motherboard RS-485 Communications TB 3	
25	Shield
29	-RX
28	+Rx
24	Common
21	+TX
20	-TX

*Maximum cable length 4000 ft
Use Beldon 9830 or equivalent*

Table 2-3: Mother Board Wiring Configuration TB 3 – RS-232 Communications

Motherboard RS-232 Communications TB 3	
25	Shield
23	CTS
24	Common
22	RxD
21	TxD
20	RTS

*Maximum cable length 50 ft
Use Beldon 9538 or equivalent*

Table 2-4: Mother Board Wiring Configuration TB 3 – 20mA Serial Communications

Motherboard 20 mA Serial Communications TB 3	
25	Shield
26	+20 mA (out)
27	-20 mA (out)
28	+20 mA (in)
24	-20 mA (in)

*Maximum cable length 4000 ft
Use Beldon 9829 or equivalent*

Table 2-5: Mother Board Communication Jumper Settings

JUMPERS							
Mode	OP1	OP2	OP3	OP10	OP13	OP11	
RS-485	"A"	"A"	"A"	"A"	"A" Normal "B" Multi-drop	"A" Terminated "B" Not Terminated	Default
RS-232	"B"	"B"	"B"	"A"	"A" Normal	"B" Not Terminated "A" Terminated	Default
20 mA	"A"	"A"	"A"	"B"	"A"	"C"	

Figure 2-5: Mother Board Area of Detail

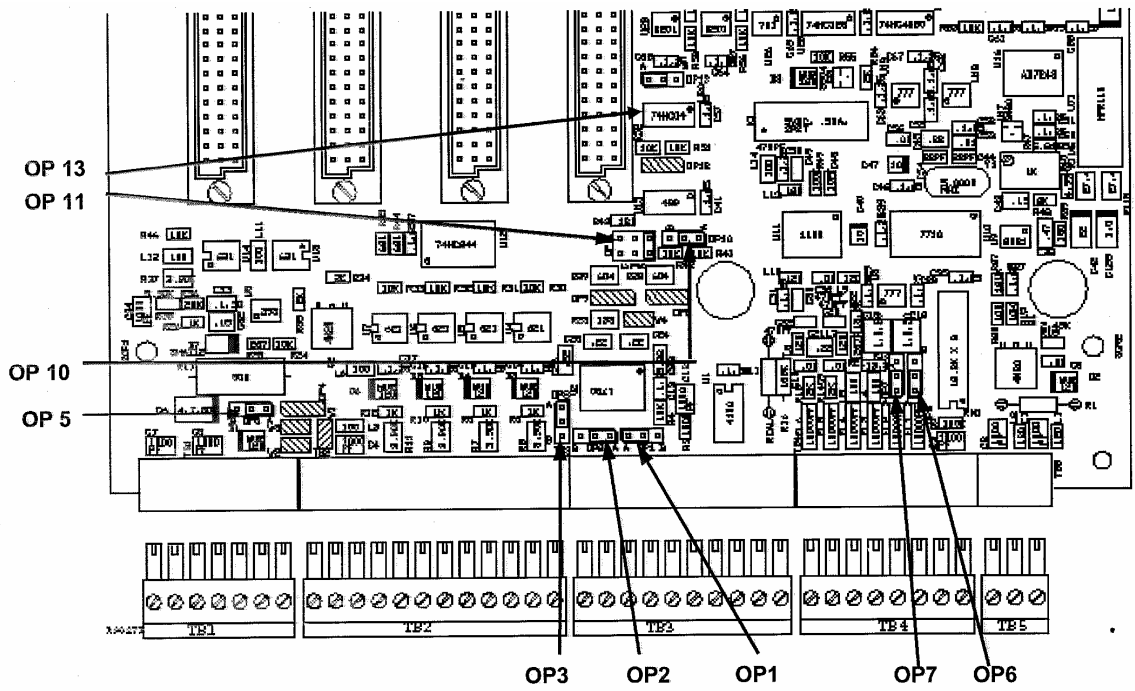

Chapter 3 Operation

3.1 General

The Micro-Tech 3107 Impact Flow Meter Controller is a bus-based menu driven machine that allows the operator easy access to all communication and printer set-up scrolls. Main Menu 3's Diagnostic Scroll contains the clock/calendar set-up screens. Main Menu 2's Display Scroll contains the clock/calendar configuration screens, and Main Menu 5 contains the communications and printer set-up scrolls.

The PRINT key enables the Micro-Tech 3107 to print the data selected in the Printer Scroll. Periodical printing and alarms print when directed by the system if enabled.

3.2 Print Key

NOTE: This section only applies to the Printer. If you are using the COMM for connecting a computer or a PLC and you are using a protocol, skip this section and refer to Chapter 2.

The Micro-Tech 3000 can print out several kinds of data, depending on the system set-up. When the printer has been installed and properly set up, the user can print by means of the PRINT key as described below.

When the PRINT key is pressed, the following screen is displayed:

```
- PRINTER SCROLL -  
COM #1 no data  
Start print TOTALS  
PRINT RETURN COM
```

Password: Not required

The second line gives the status of the printer:

NO DATA Indicates the printer is idle, no data is being sent to the printer.

IS RUNNING Indicates the system is sending data to the printer.

The third line indicates what kind of data is printed if the PRINT soft key is pressed.

The UP and DOWN keys select between:

- a. TOTALS Prints the selected totals format. Default1, Default2, or User Define (see Section 3.4.5).
- b. BATCH Only if load out option is active, print load out information.
- c. SETUP Print the set-up data of the instrument.
- d. TRAILS If audit trails option is active, print audit trails data. (See Main Menu 6 in the Micro-Tech 2000 manuals.)

Print starts after the PRINT soft key is pressed.

The COM key allows the operator to select the printer if more than one is installed.

3.3 Print Formats

The printer can be set up to print totals, batch reports, instrument set-up data, and audit trails upon request. Batch reports and audit trails require optional hardware. In addition, totals can be printed at four predetermined intervals and enabled alarms at the time they occur.

3.3.1 Totals

There are three formats for printing totals; two of them are predefined, one is user programmable. Selection between the different formats is done via menus, as described in the next paragraphs.

The first predefined format is named **DEFAULT1**, and prints data in the following way:

TOTALS REPORT

```
DATE: 03-10-2002
TIME: 8:12a

MASTER TOTAL      :      0.00 Tons
RESET TOTAL #01   :      0.00 Tons
RESET TOTAL #02   :      0.00 Tons
RESET TOTAL ...
OPERATOR TOTAL #01 :      0.00 Tons
OPERATOR TOTAL #02 :      0.00 Tons
OPERATOR TOTAL ...
RATE              :      0.00 Tph
```

The second predefined format is named **DEFAULT 2**, and prints data in the following way:

```
DATE: 03-10-2002
TIME: 8:12a

MASTER START TOTAL : 0.00 Tons
MASTER STOP TOTAL  : 0.00 Tons
QUANTITY           : 0.00 Tons
```

In both cases, the format in which date and time are printed depends on the system set-up.

The last method called **USER DEFINED**, is to define your own format using the printer set up screens as described in Section 3.3.4.

The **USER DEFINED** format includes three programmable strings and a mean of printing the average rate during totalization. The position of each datum on the paper can be assigned by row and column, making it easy to fulfill any custom requirement.

3.3.2 Batch

If the optional Load Out board is installed, the load out data can be printed in the following format:

```
BATCH REPORT  
  
DATE: 03-10-2002  
TIME: 8:12a  
  
BATCH NR: 0  
SET PT: 0.00 Tons  
TOTAL : 0.00 Tons
```

3.3.3 Alarms

The system can optionally print out each alarm (if the alarm has been turned on in the Alarms Menu) in the following format:

```
03-10-2002 8:14a  
High rate
```

where "High rate" is only an example of a possible alarm condition. Date and time corresponds to when the alarm has occurred the first time.

3.3.4 Set Up

The entire system set-up data can be printed by the unit for the customer's record. Format and sequence of data can vary depending on the hardware and software configurations.

3.3.5 Audit Trails

When Audit Trails is installed, the recorded data can be printed out in the following format:

```
TRAIL RECORD NR 1  
DATE 03-10-2002 TIME 11:59p  
VARIABLE scale cap  
NEW 400.00  
OLD 500.00
```

```
TRAIL RECORD NR 2  
DATE 03-10-2002 TIME 11:31p  
VARIABLE span  
NEW 250000  
OLD 300000
```

```
TRAIL RECORD NR 3  
DATE 03-10-2002 TIME 11:59p  
VARIABLE div (e)  
NEW 0.05  
OLD 0.1
```

Each record contains a description of the variable which has been altered, the old and the new values of the variable, and an index number.

3.4 Communication Set-Up

This section explains the communication and printer set-up. See Section for communication protocols detailed description.

3.4.1 Clock/Calendar Set-Up

When an COMM A board is installed, date and time become available and must be set. The battery, located on the mother board, provides backup for the perpetual calendar/clock. Time and date needs to be set only once.

1. Press the MENU key until Main Menu 3 appears. Press the soft key under the DIAGNOSTICS scroll and scroll down until -DIAGNOST SCROLL 7- appears.

The following scroll is provided to set up the date, and enter the day, month and year in sequence.

<p>-DIAGNOST. SCROLL 7- Date: DD-MM-YYYY DAY: DD ENTER</p>
--

Password : SERVICE

Default: 00-00-0000
Min: 01-01-0000
Max: 12-31-2002

Time is entered in a similar way. The **AM/PM** key is used when time is in the English mode (see Display Scroll 7 below).

<p>-DIAGNOST. SCROLL 8- Time: HH:MM HOURS: HH ENTER AM/PM</p>
--

Password: SERVICE

	24 hour	am/pm
Default:	00:00	01:00
Min:	00:00	01:00
Max:	23:59	12:59

2. Press the MENU key until Main Menu 2 appears. Press soft key under DISPLAY scroll and scroll down until -DISPLAY SCROLL 7- appears.

The user can define the format for displaying and printing time and date. Select the 24 hours or 12 hours format:

```
- DISPLAY SCROLL 7 -  
Time  
> 24 h <  
CHOICE ENTER
```

Password: Service

If USA or English: Default: am/pm
If other language: Default: 24 h
Selections: am/pm, 24 h

Then date can be set to show month or day first, in three possible configurations:

```
- DISPLAY SCROLL 8 -  
Date  
> DD-MM-YYYY <  
CHOICE ENTER
```

Password: Service

If USA: Default: MM-DD-YYYY
If other language: Default: DD-MM-YYYY
Selections: DD-MM-YYYY, MM-DD-YYYY, YYYY-MM-DD

3. When a COMM board is installed, date and time can be displayed line three (3) in the RUN screen if selected using DISPLAY SCROLL 9.

```
- DISPLAY SCROLL 9 -  
Run display line 3  
> No Display <  
CHOICE ENTER
```

Password: Service

Default: NO DISPLAY
Selections: NO DISPLAY, LOAD, SPEED, DATE/TIME

3.4.2 COMM A and Print Scroll Set-Up

Main Menu 5 is dedicated to the serial line. COMM A is used to set up the serial line of the COMM A, regardless if the serial line is connected to a computer or a PLC or for printing. The PRINT scroll is used for setting up the printer, and it only appears if the COMM A is set for printer.

```
- MAIN MENU 5 -  
Press MENU for more  
  
COMM A PRINT
```

Serial Communications 3107

1. Line Setting and Protocol Definition

Two COMM line can be installed and programmed, typically one for the printer and one for the supervisor.

The following screens define the communication parameters for the first and the second channel.

```
- COMM. A SCROLL 1 -  
  Baud rate port #1  
> 2400 <  
CHOICE ENTER
```

Password: Service

Default: 9600

Selections: 110, 150, 300, 600, 1200, 2400, 4800, 9600, 19200

```
- COMM. A SCROLL 2 -  
  Set parity port #1  
> No parity <  
CHOICE ENTER
```

Password: Service

Default: NO PARITY

Selections: EVEN PARITY, ODD PARITY, NO PARITY

```
- COMM. A SCROLL 3 -  
  Stop bits port #1  
> 1 <  
CHOICE ENTER
```

Password: Service

Default: 1

Selections: 1,2

```
- COMM. A SCROLL 4 -  
  Wordlength port #1  
> 8 <  
CHOICE ENTER
```

Password: Service

Default: 8

Selections: 7,8

The next screen defines the port use. Some commonly used protocols are implemented in the system. Possible selections are:

PC-MASTER Ramsey proprietary protocol: Multidrop, Master Slave.

SIEMENS 3964R A proprietary protocol of Siemens. Point to point, Multi Master.

ALLEN-BRADLEY A proprietary protocol of Allen-Bradley.
DF1 Multidrop, Master Slave.

MODBUS A proprietary protocol of AEG. Multidrop, Master Slave.

PRINTER Not a protocol, selects printer output.

```
- COMM. A SCROLL 5 -  
Protocol port #1  
> MODBUS <  
CHOICE ENTER
```

Password: Service

Default: MODBUS

Selections: PC-MASTER, SIEMENS 3964R, ALLEN-BRADLEY DF1, MODBUS, PRINTER

If the option COMM A board is installed, the following screen appears. These screens operate exactly as the ones dedicated to the COMM A on the Mother Board.

```
- COMM. A SCROLL 8 -  
  Baud rate port #2  
> 2400 <  
CHOICE ENTER
```

Password: Service

Default: 9600

Selections: 110, 150, 300, 600, 1200, 2400, 4800, 9600, 19200

```
- COMM. A SCROLL 9 -  
Set parity port #2  
> No parity <  
CHOICE ENTER
```

Password: Service

Default: NO PARITY

Selections: EVEN PARITY, ODD PARITY, NO PARITY

```
- COMM. A SCROLL 10 -  
Stop bits port #2  
> 1 <  
CHOICE ENTER
```

Password: Service

Default: 1

Selections: 1,2

```
- COMM. A SCROLL 11 -  
Wordlength port #2  
> 8 <  
CHOICE ENTER
```

Password: Service

Default: 8

Selections: 7,8

```
- COMM. A SCROLL 12 -  
Protocol port #2  
> PRINTER <  
CHOICE ENTER
```

Password: Service

Default: PRINTER
Selections: PC-MASTER, SIEMENS 3964R, ALLEN-BRADLEY DF1, MODBUS, PRINTER

3.4.3 Multidrop Operator Set-Up

NOTE: This section only applies to multidrop operation. If you are using the COMM for connecting a printer, skip this section and refer to Section 3.4.4. The Clear To Send (CTS) line of the port can be used for hardware handshake. Select Enabled if you want to connect the CTS input of the system to a control signal generated by the other device.

WARNING

**THE CTS INPUT CAN ONLY BE USED WHEN JUMPERS ARE SET FOR RS232.
ATTEMPTING TO ENABLE THE CTS SOFTWARE CONTROL IN RS485 MODE
WILL RESULT IN LOCK-UP OF THE LINE.**

```
- COMM. A SCROLL 5A -  
Clear to Send #1  
> Disabled <  
CHOICE ENTER
```

Password: Service

Default: DISABLED
Selections: ACTIVE, DISABLED

The following screens define the ADDRESS of the device in the multidrop line, and the access permission from the remote supervisor. If NONE is selected, the supervisor has full access to the device. If LIMITED is selected, the supervisor can only access those variables that are accessible with the OPERATOR password. If PROTECTED is selected, the unit is read only to the supervisor.

```
- COMM. A SCROLL 6 -  
Address port #1  
> 1 <  
ENTER
```

Password: Service

Default: 1
Min: 1
Max: 255

```
- COMM. A SCROLL 7 -  
Access prot port #1  
> None <  
CHOICE ENTER
```

Password: Service

Default: NONE
Selection: NONE, LIMITED, PROTECTED

Similarly for COMM 2, if installed:

```

- COMM. A SCROLL 12A -
Clear to Send #2
> Disabled <
CHOICE ENTER
    
```

Password: Service

Default: DISABLED
 Selections: ACTIVE, DISABLED

```

- COMM. A SCROLL 13 -
Address port #2
> 1 <
ENTER
    
```

Password: Service

Default: 1
 Min: 1
 Max: 255

```

- COMM. A SCROLL 14 -
Access prot port #2
> None <
CHOICE ENTER
    
```

Password: Service

Default: NONE
 Selection: NONE, LIMITED, PROTECTED

3.4.4 Printer Set-Up

NOTE: This section only applies to printer. If you are using the COMM for connecting a computer, PLC or other device using a protocol, skip this section and refer to Section 3.4.3.

The Micro-Tech 3000 has a fully programmable printer format. The following section explains how to program the Print scroll according to the specific needs.

The system can be configured to operate without any handshake (NONE), or using the Clear To Send signal (CTS) or the XON-XOFF sequence. Refer to the instruction manual of the printer to define which selection is required. The selection NONE is only supplied for testing purposes, but is not recommended for normal use. If NONE is selected, the system is not able to recognize if the printer is on line or not, or if the paper is empty.

The most commonly used protocol is the CTS, which is a signal generated by the printer to indicate whether it is ready to receive data or not.

WARNING

**THE CTS INPUT CAN ONLY BE USED WHEN JUMPERS ARE SET FOR RS232.
 ATTEMPTING TO ENABLE THE CTS SOFTWARE CONTROL IN RS485 MODE
 WILL RESULT IN LOCK-UP OF THE LINE.**

Serial Communications 3107

- PRINTER SCROLL 1 -
Handshaking
> **None** <
CHOICE ENTER

Password: Service

Default: NONE
Selection: NONE, CTS, XON-XOFF

Different printers use different end of line patterns. Select the one you need according to the printer.

- PRINTER SCROLL 2 -
End of line
> **CR** <
CHOICE ENTER

Password: Service

Default: CR
Selection: CR, LF, CR+LF

Some simple printers cannot accept characters while they are printing. In some cases the handshake is not well controlled by the printer, so a delay at end of line is helpful.

- PRINTER SCROLL 3 -
Delay end of line
0 sec
ENTER

Password: Service

Default: 0 sec
Min: 0 sec
Max: 5 sec

A Form Feed character can be sent to the printer after each report to force the printer to eject the paper.

- PRINTER SCROLL 4 -
Form Feed
> **NO** <
CHOICE ENTER

Password: Service

Default: NO
Selections: NO, YES

If you want to generate periodical printing, enter the number of minutes, hours or days in the following screen. By entering 0, the periodical printing is prevented. Use the INTV key to switch from minutes to hours and to days.

- PRINTER SCROLL 5 -
Print interval
0 min
ENTER INTV

Password: Service

Default: 0
Min: 0 min, 0 hour, 0 days
Max: 59 min, 23 hour, 365 days

The system can print at specific times during the day. Enter the time you want to obtain the printing. Use the NEXT keys to scroll between the print times. Up to four discrete times may be entered. The ON/OFF key enables or disables the displayed print time.

```

- PRINTER SCROLL 6 -
Print time # 1
time HH:MM
ENTER ON/OFF NEXT
    
```

Password: Operator

Default: OFF
 Min: 00:00
 Max: 23:59

3.4.5 Define Printing Format

By selecting YES in the following screen, the system is instructed to print one line each time a new alarm condition occurs. The alarm is printed as follows:

```

xx-xx-xxxx yy:yyz
kkkkkkkkkkkkkkkkkkkk
    
```

where:

xx-xx-xxxx	Day, Month, Year, printed according to the local format as defined in Main Menu 2 - Display.
yy:yyz	Hour, Minutes, am/pm printed according to the local format as defined in Main Menu 2 - Display
kkkkkkkkkkkkkkkkkkkk	Alarm message, same message appearing on the screen.

For example:

```

09-10-2002 8:14a
High rate
    
```

```

- PRINTER SCROLL 7 -
Print alarms
> No <
CHOICE ENTER
    
```

Default: NO
 Selections: NO, YES

If YES is selected, the system prints all alarms that have been set to alarm in the Alarm scroll.

There are three ways for defining the printing format. The first two are predefined formats, which are as follows:

1. DEFAULT 1
 TOTALS REPORT

 DATE: 03-10-2002
 TIME: 8:12a

Serial Communications 3107

MASTER TOTAL 0.00 Tons
RESET TOTAL: #01 0.00 Tons
RESET TOTAL: #02 0.00 Tons
OPERATOR TOTAL: #01 0.00 Tons
OPERATOR TOTAL: #02 0.00 Tons
RATE: 0.00 Tph

#1, #2 indicates product number and can change between 1 and 99.

2. DEFAULT 2

DATE: 03-10-95
TIME: 8:12a

MASTER START TOTAL: 0.00 Tons
MASTER STOP TOTAL: 0.00 Tons
QUANTITY: 0.00 Tons

The format "DEFAULT 2" is preselected when the W&M is set to NTEP.

3.4.6 Setting the Printer Inhibit Range

The Printer Inhibit Range setting prevents printing when the rate is higher than a preset value. This is a requirement of NTEP, and therefore automatically turned on when the NTEP W&M mode is selected.

- PRINTER SCROLL 12P -
Print Inhibit range
0 %
ENTER

Password: Service

Default: 3%
Min: 0%
Max: 100%

3.4.7 Additional Diagnostic

If a Communication board is detected, the following screen is shown. The "Port 2" soft key is only shown if two boards are detected.

- TEST SCROLL 8 -
Test communication A
PORT1 PORT2

Password: Service

By pressing the PORT 1 or the PORT 2 soft key the test is initiated. A test pattern is sent out on the TX output and read on the RX input. If the test fails, the message TEST FAILED is shown, otherwise the message TEST PASSED is displayed.

NOTE: This test requires a hardware jumper to be installed between the (RX) and (TX) terminals of the communication board.

3.5 Communication Protocols

The communication protocol allows a remote intelligent device to read and eventually write the contents of the registers as listed in this section.

During the communication activity, the Micro-Tech 3000 always acts as Slave, meaning that it will respond to a request from a Master device on the line, but never attempts to send messages out.

The instrument responds only if the message is completely received. The instrument reads the message and looks for the address, which is contained in an address byte in the query package. The message is then processed only if the address contained in the message matches the address specified in the set-up data of the instrument. When the system receives a message, the integrity of it is checked, and an answer message is prepared if yes.

The Master must respect a 100 ms interval time between two messages. If a message is sent before 100 ms have passed since the previous one, it is lost. (The data is received by an interrupt routine, while it is processed in a task which is executed each 100 ms.)

If the Master sends variables to be written in memory, the system checks the correctness of the message, and immediately sends an answer message if it is correct. This does not necessarily mean that the data is written in memory. The system first checks the address, which must correspond to a valid address of a variable, then the minimum and maximum limits are checked, and then the password. If data can be accepted, the success flag is set to 0 (no error), if not, it is set to 1. The Master needs to check the success flag (contained into a read only register), to know if the last variables sent have been stored or not.

The procedure is as follows:

- Send the data to the Micro-Tech 3000
- Wait 100 ms
- Read the success flag, should be 0.

Some data is read only, some is read write, some is write only.

NOTE: The maximum number of words the system can transfer is 41 per time. Requests of registers in excess of 41 are treated as errors and do not generate an answer.

NOTE: This section only applies to multidrop operation. If you are using the COMM option for connecting a Printer, skip this section and refer to Section 3.4.4.

3.5.1 Register Definition

The following registers can be accessed through a serial line link using one of the available communication protocols. The table lists the registers specifying per each:

- register	A conventional name		
- type	Can be:	RO	The register can be read but cannot be written.
		RW	The register can be read or written. Write is allowed if the instrument is in the specified protection level at the moment the write message is received.

Serial Communications 3107

	WO	The register can only be written. Write is subject to protection control.
- low limit		The minimum acceptable value for the variable. Lower values are considered as errors.
- high limit		The maximum acceptable value for the variable. Higher values are considered as errors.
- refresh time		The time between two updates of the variable in the instrument's memory.
- protection		The minimum protection level which must be in place to allow access to the variable: - always available limited available if limited or service service available if service only
- format	Can be:	char An ASCII string integer 16 bits IEEE integer float 32 bits IEEE float

WARNING

THE ACTUAL ADDRESS OF EACH REGISTER IS DEFINED DIFFERENTLY FOR EACH PROTOCOL AS EXPLAINED IN THE FOLLOWING SECTIONS.

1. Type, Limits and Format of Register

register	type	low limit	high limit	refresh time [ms]	protection	format
success_flag	RO	-	-	-	none	integer
display	RO	-	-	100	-	char
leds	RO	-	-	100	-	integer
status	RO	-	-	100	-	integer
alarms	RO	-	-	100	-	integer
i_o	RO	-	-	100	-	integer
commands	WO	0	32767	100	none	integer
product number	RW	1	99	100	limited	integer
rate	RO	-	-	100	-	float
master_total	RO	-	-	100	-	float
reset_total	RW	0 (1)	0 (1)	100	none	float
operator_total	RW	0 (1)	0 (1)	100	limited	float
batch_total	RO	-	-	100	-	float
batch_number	RW	0	999	100	limited	integer
batch_set	RW	0	10000	-	limited	float
batch_pre_set	RW	0	10000	-	limited	float
batch_pre_act	RW	0	10000	-	limited	float
batch_deviation	RW	0	100	-	limited	integer
scale_capacity	RW	1	200000	-	service	float
high_rate_set	RW	0	105.0%	-	limited	float
low_rate_set	RW	0	103.0%	-	limited	float
percent of ingred._1	RW	0%	100%		limited	integer
percent of ingred._2	RW	0%	100%		limited	integer
batch_per_set	RW	0.0%	100.0%		limited	float
reg_set_point_1	RW	0	20000.0	-	limited	float
reg_set_point_2	RW	0	20000.0	-	limited	float

Serial Communications 3107

dsp_set_point_1	RO	-	-	100 mS	-	float
dsp_set_point_2	RO	-	-	100 mS	-	float
percent of ingred._2	RW	0%	100%		limited	integer
batch_per_set	RW	0.0%	100.0%		limited	float
reg_set_point_1	RW	0	20000.0	-	limited	float
reg_set_point_2	RW	0	20000.0	-	limited	float
dsp_set_point_1	RO	-	-	100 mS	-	float
dsp_set_point_2	RO	-	-	100 mS	-	float

(1) Can only be zeroed.

2. Description of Register

In the following section an explanation is given per each variable of the above table.

a. success_flag

Set to 0 after a message has been received and properly processed. If a message is correctly received but cannot be processed because password protection or size error, this flag is set to 1. The user may read this register after a write message to ensure the data have been accepted.

b. display

It contains the messages actually shown on the display of the instrument in form of an ASCII string. For example, the screen:

- MENU MAIN 1 -
PRESS MENU FOR MORE
ZERO SPAN
CAL CAL

Will be stored in registers in the following way:

display(1)	2DH	20H	Characters 1 and 2 from left of first row
display(2)	4DH	45H	
display(3)	4EH	55H	
display(4)	20H	4DH	
display(5)	41H	49H	
display(6)	4EH	20H	
.....			
display(10)	Characters 19 and 20 from left of first row
display(11)	Characters 1 and 2 from left second row
.....			
display(20)	Characters 19 and 20 from left of second row
display(21)	Characters 1 and 2 from left of third row
.....			
display(30)	Characters 19 and 20 from left of third row
display(31)	Characters 1 and 2 from left of fourth row
.....			
display(38)	4CH	20H	

display(39) 20H 20H
 display(40) 20H 20H Characters 19 and 20 from left of fourth row

c. leds

Leds(1)	<u>bit</u>	<u>description</u>
	15	not used
	.	.
	05	not used
	04	led 5 (1 = on, 0 = off)
	03	led 4
	02	led 3
	01	led 2
	00	led 1

d. status

Status(1)	<u>bit</u>	<u>description</u>
	15	cumulative shutdown (a shutdown alarm is pending)
	14	cumulative alarms (an alarm is pending)
	13	calibration running
	12	remote (1) local (0)
	11	automatic (1) manual (0)
	10-8	Not used
	07	Not used
	06	Not used
	05	High rate (Rate is higher than limit)
	04	Low rate (Rate is lower than limit)
	03-0	Not used

Status(2)	<u>bit</u>	<u>description</u>
	15	high pos deviation #1
	14	high high pos deviation #1
	13	high neg deviation #1
	12	high high neg deviation #1
	11	high pos deviation #2
	10	high high pos deviation #2
	09	high neg deviation #2
	08	high high neg deviation #2
	07-04	not used
	03-00	Only applicable if Load Out option installed:
		3 2 1 0
	X 0 0 0	Batch not running
	X 0 0 1	Not used
	X 0 1 0	Batch running at high rate
	X 0 1 1	Batch running at low rate
	X 1 0 0	Waiting start delay time
	X 1 0 1	Waiting stabilization time

x can be 0 Normal status
 1 Stand by status

Serial Communications 3107

e. alarms

In the alarms register, each bit represents the status of an alarm. If the alarm is active, the relevant bit contains '1', otherwise it contains '0'.

alarms(1)	<u>bit</u>	<u>description</u>
	15	CLOCK FAIL
	14	BAD WEIGHT SIGNAL
	13	RAM FAIL
	12	ROM FAIL
	11	HIGH RATE
	10	LOW RATE
	09	WARM START
	08	COLD START
	07	PW DURING CALIB
	06	CAL TIME ELAPSED
	05	EXTERN ALARM 1
	04	EXTERN ALARM 2
	03	EXTERN ALARM 3
	02	OVERFLOW TOTALIZER
	01	AZT OVER LIMIT
	00	BATCH DEVIATION

alarms(2)	<u>bit</u>	<u>description</u>
	15	COMMUNICATION ERROR
	14	BCD OVERFLOW
	13	MATHEMATIC ERROR
	12	HW CNF CHANGE SLOT 1
	11	HW CNF CHANGE SLOT 2
	10	HW CNF CHANGE SLOT 3
	09	
	08	
	07	
	06-0	NOT USED

alarms(3)	<u>bit</u>	<u>description</u>
	15-09	NOT USED
	08	HIGH POS DEVIATION #1
	07	HIGH HIGH POS DEVIATION #1
	06	HIGH NEG DEVIATION #1
	05	HIGH HIGH NEG DEVIATION #1
	04	HIGH POS DEVIATION #2
	03	HIGH HIGH POS DEVIATION #2
	02	HIGH NEG DEVIATION #2
	01	HIGH HIGH NEG DEVIATION #2
	00	NOT USED

f. i_o

The instrument has physical inputs and outputs to which logical input and output functions are associated. As far as communication is concerned, only the status of physical inputs and outputs are transferred.

i_o(1)	<u>bit</u>	<u>description</u>
	15-04	not used
	03	in 3 – mother board
	02	in 2 – mother board
	01	in 1 – mother board
	00	in 0 – mother board
i_o(2)	<u>bit</u>	<u>description</u>
	15	in 3 board 4in/16out # 1
	14	in 2 board 4in/16out # 1
	13	in 1 board 4in/16out # 1
	12	in 0 board 4in/16out # 1
	11	in 3 board 4in/16out # 2
	10	in 2 board 4in/16out # 2
	09	in 1 board 4in/16out # 2
	08	in 0 board 4in/16out # 2
	07	in 3 board 4in/16out # 3
	06	in 2 board 4in/16out # 3
	05	in 1 board 4in/16out # 3
	04	in 0 board 4in/16out # 3
	03	in 3 board 4in/16out # 4
	02	in 2 board 4in/16out # 4
	01	in 1 board 4in/16out # 4
00	in 0 board 4in/16out # 4	
i_o(3)	<u>bit</u>	<u>description</u>
	15	in 15 board 16in/4out # 1
	14	in 14 board 16in/4out # 1
	13	in 13 board 16in/4out # 1
	12	in 12 board 16in/4out # 1
	11	in 11 board 16in/4out # 1
	10	in 10 board 16in/4out # 1
	09	in 09 board 16in/4out # 1
	08	in 08 board 16in/4out # 1
	07	in 07 board 16in/4out # 1
	06	in 06 board 16in/4out # 1
	05	in 05 board 16in/4out # 1
	04	in 04 board 16in/4out # 1
	03	in 03 board 16in/4out # 1
	02	in 02 board 16in/4out # 1
	01	in 01 board 16in/4out # 1
00	in 00 board 16in/4out # 1	
i_o(4)	<u>bit</u>	<u>description</u>
	15	in 15 board 16in/4out # 2
	14	in 14 board 16in/4out # 2
	13	in 13 board 16in/4out # 2
	12	in 12 board 16in/4out # 2
	11	in 11 board 16in/4out # 2
	10	in 10 board 16in/4out # 2
09	in 09 board 16in/4out # 2	
08	in 08 board 16in/4out # 2	
07	in 07 board 16in/4out # 2	
06	in 06 board 16in/4out # 2	

Serial Communications 3107

05	in 05	board 16in/4out # 2
04	in 04	board 16in/4out # 2
03	in 03	board 16in/4out # 2
02	in 02	board 16in/4out # 2
01	in 01	board 16in/4out # 2
00	in 00	board 16in/4out # 2

i_o(5)	<u>bit</u>	<u>description</u>
	15	in 15 board 16in/4out # 3
	14	in 14 board 16in/4out # 3
	13	in 13 board 16in/4out # 3
	12	in 12 board 16in/4out # 3
	11	in 11 board 16in/4out # 3
	10	in 10 board 16in/4out # 3
	09	in 09 board 16in/4out # 3
	08	in 08 board 16in/4out # 3
	07	in 07 board 16in/4out # 3
	06	in 06 board 16in/4out # 3
	05	in 05 board 16in/4out # 3
	04	in 04 board 16in/4out # 3
	03	in 03 board 16in/4out # 3
	02	in 02 board 16in/4out # 3
	01	in 01 board 16in/4out # 3
00	in 00 board 16in/4out # 3	

i_o(6)	<u>bit</u>	<u>description</u>
	15	in 15 board 16in/4out # 4
	14	in 14 board 16in/4out # 4
	13	in 13 board 16in/4out # 4
	12	in 12 board 16in/4out # 4
	11	in 11 board 16in/4out # 4
	10	in 10 board 16in/4out # 4
	09	in 09 board 16in/4out # 4
	08	in 08 board 16in/4out # 4
	07	in 07 board 16in/4out # 4
	06	in 06 board 16in/4out # 4
	05	in 05 board 16in/4out # 4
	04	in 04 board 16in/4out # 4
	03	in 03 board 16in/4out # 4
	02	in 02 board 16in/4out # 4
	01	in 01 board 16in/4out # 4
00	in 00 board 16in/4out # 4	

i_o(7)	<u>bit</u>	<u>description</u>
	15-04	not used – mother board
	03	out 3 – mother board
	02	out 2 – mother board
	01	out 1 – mother board
00	out 0 – mother board	

i_o(8)	<u>bit</u>	<u>description</u>
	15	out 3 board 16in/4out # 1
	14	out 2 board 16in/4out # 1
13	out 1 board 16in/4out # 1	

12	out 0	board 16in/4out # 1
11	out 3	board 16in/4out # 2
10	out 2	board 16in/4out # 2
09	out 1	board 16in/4out # 2
08	out 0	board 16in/4out # 2
07	out 3	board 16in/4out # 3
06	out 2	board 16in/4out # 3
05	out 1	board 16in/4out # 3
04	out 0	board 16in/4out # 3
03	out 3	board 16in/4out # 4
02	out 2	board 16in/4out # 4
01	out 1	board 16in/4out # 4
00	out 0	board 16in/4out # 4

i_o(9)	<u>bit</u>	<u>description</u>
	15	out 15 board 4in/16out # 1
	14	out 14 board 4in/16out # 1
	13	out 13 board 4in/16out # 1
	12	out 12 board 4in/16out # 1
	11	out 11 board 4in/16out # 1
	10	out 10 board 4in/16out # 1
	09	out 09 board 4in/16out # 1
	08	out 08 board 4in/16out # 1
	07	out 07 board 4in/16out # 1
	06	out 06 board 4in/16out # 1
	05	out 05 board 4in/16out # 1
	04	out 04 board 4in/16out # 1
	03	out 03 board 4in/16out # 1
	02	out 02 board 4in/16out # 1
	01	out 01 board 4in/16out # 1
	00	out 00 board 4in/16out # 1

i_o(10)	<u>bit</u>	<u>description</u>
	15	out 15 board 4in/16out # 2
	14	out 14 board 4in/16out # 2
	13	out 13 board 4in/16out # 2
	12	out 12 board 4in/16out # 2
	11	out 11 board 4in/16out # 2
	10	out 10 board 4in/16out # 2
	09	out 09 board 4in/16out # 2
	08	out 08 board 4in/16out # 2
	07	out 07 board 4in/16out # 2
	06	out 06 board 4in/16out # 2
	05	out 05 board 4in/16out # 2
	04	out 04 board 4in/16out # 2
	03	out 03 board 4in/16out # 2
	02	out 02 board 4in/16out # 2
	01	out 01 board 4in/16out # 2
	00	out 00 board 4in/16out # 2

i_o(11)	<u>bit</u>	<u>description</u>
	15	out 15 board 4in/16out # 3
	14	out 14 board 4in/16out # 3
	13	out 13 board 4in/16out # 3

Serial Communications 3107

12	out 12	board 4in/16out # 3
11	out 11	board 4in/16out # 3
10	out 10	board 4in/16out # 3
09	out 09	board 4in/16out # 3
08	out 08	board 4in/16out # 3
07	out 07	board 4in/16out # 3
06	out 06	board 4in/16out # 3
05	out 05	board 4in/16out # 3
04	out 04	board 4in/16out # 3
03	out 03	board 4in/16out # 3
02	out 02	board 4in/16out # 3
01	out 01	board 4in/16out # 3
00	out 00	board 4in/16out # 3

i_o(12)	<u>bit</u>	<u>description</u>
	15	out 15 board 4in/16out # 4
	14	out 14 board 4in/16out # 4
	13	out 13 board 4in/16out # 4
	12	out 12 board 4in/16out # 4
	11	out 11 board 4in/16out # 4
	10	out 10 board 4in/16out # 4
	09	out 09 board 4in/16out # 4
	08	out 08 board 4in/16out # 4
	07	out 07 board 4in/16out # 4
	06	out 06 board 4in/16out # 4
	05	out 05 board 4in/16out # 4
	04	out 04 board 4in/16out # 4
	03	out 03 board 4in/16out # 4
	02	out 02 board 4in/16out # 4
	01	out 01 board 4in/16out # 4
	00	out 00 board 4in/16out # 4

g. commands

Each bit of the commands register is specified as follows :

<u>Bit</u>	<u>Description</u>	<u>Action</u>
15 (MSB)	Not used	
14	Not used	
13	Not used	
12	Not used	
11	Not used	
10	Not used	
09	Not used	
08	Not used	
07	Not used	
06	Not used	
05	Not used	
04	Not used	
03	Stand by Batch	Only if Load Out option installed. Temporarily stops a Load Out (batch) sequence. Batch can resume if a Start command is sent later.

02	Stop Batch	Only if Load Out option installed. Stops a Load Out (batch) sequence.
01	Start Batch	Only if Load Out option installed. Starts a Load Out (batch) sequence.
00	Reset Alarms	Reset any pending alarm

In order to give a command, the Host must set the relevant bit to 1 and write (send) the register to the instrument. The action is performed if the write message is accepted.

- h. product number
The current value of the product number as currently displayed on the RUN screen.
- i. rate
The instantaneous rate in engineering units as currently displayed on the RUN screen.
- j. master_total
The current value of the master totalizer of the impact flow meter.
- k. reset_total
The current value of the reset totalizer of the impact flow meter. Reset total can be zeroed by writing zero to this register.
- l. operator_total
The current value of the operator totalizer of the impact flow meter. Operator total can be zeroed by writing zero to this register.

NOTE: The registers from m. to r. only apply if the optional Load Out option is installed.
- m. batch_total
The current contents of the load out totalizer. Usually read at end of batch to check the result of the load out. This register is automatically cleared when a new batch is started.
- n. batch_number
The number of the currently running load out or the number of the last finished one. The instrument automatically increments the batch number when a new batch is started.
- o. batch_set
The set point for the current or the next load out. Usually entered or downloaded by the user.
- p. batch_pre_set
The pre-set point for the current or the next load out. Set by the user, defines when the rate is lowered to increase batch accuracy.

Serial Communications 3107

- q. batch_pre_act
The set point of the pre act for the current or the next load out. Entered or downloaded by the user (if in MANUAL mode) or calculated by the instrument. Defines when the load out has to stop to compensate the queue of material from the loading point to the scale.
- r. batch_deviation
The maximum acceptable deviation from the batch set point. Usually entered by the user.
- s. scale capacity
The rate capacity of the instrument. Entered by the user at first start up, should never be altered.
- t. high_rate_set
The set point for the alarm of high rate. Entered or downloaded by the user.
- u. low_rate_set
The set point for the alarm of low rate. Entered or downloaded by the user.
- v-z Not used
- aa-bb Not used
 - cc. reg_set_point_1
Set point of the regulator that can be downloaded by the Master through the serial communication line. This set point is only used if "SET POINT SOURCE" in CNTRL 1 SCROLL 9 is set up for "SERIAL LINE". Otherwise, it is ignored.
 - dd. dsp_set_point
The actual set point of the regulator. May be the same as reg_set_point or a local or analog input depending on the system set up.
 - ee. ctr_deviation
Current deviation from the set point in percent.
 - ff. hi_pos_dev
Set point for the high positive deviation alarm.
 - gg. hi_hi_pos_dev
Set point for the high high positive deviation alarm.
 - hh. hi_neg_dev
Set point for the high negative deviation alarm.
 - ii. hi_hi_neg_dev
Set point for the high high negative deviation alarm.
 - jj. percent of ingred. 1/2
It defines the ratio between the actual and remote set point (optional input in mA).
 - mm. preset set point
It defines the slow rate factor in percent of actual set point.

3.6 PC-Master

The PC-Master protocol is fully described in the following manual (available from Thermo Ramsey on request) :

PC-MASTER COMMUNICATION PROTOCOL

The following messages are used to communicate with MT3000 type of instruments:

- Message #97 : Send a Key to the MT3000
- Message #98 : Send a variables to the MT3000
- Message #99 : Get variables from the MT3000

3.6.1 Description

1. Message #97 : SEND A KEY TO THE 3000

With this command, the code of one or more kays can be sent to the instrument. When the keys are received by the instrument, they are processed as the normal keyboard entries.

QUERY MESSAGE

Begin of frame	STX	02
	DLE	10H
Address	xxx	xxx
Code	97	61H
Stamp	xxx	xxx
Data	KEY	1byte
Error check	xxx	xxx
End of frame	ETX	03

RESPONSE MESSAGE

No response is provided.

TABLE OF THE KEYS

KEY	HEX CODE	KEY	HEX CODE
UP ARROW	48H	EIGHT	38H
DOWN ARROW	50H	NINE	39H
DECIMAL POINT	2EH	MENU	4DH
CLEAR	53H	RUN	52H
ZERO	30H	F1	3FH
ONE	31H	F2	40H
TWO	32H	F3	41H
THREE	33H	TOTAL	3BH
FOUR	34H	PRINT	3CH
FIVE	35H	START	3DH
SIX	36H	STOP	3EH
SEVEN	37H		

Example 1:

The Host sends the "MENU"key to 3000 (Address of Slave 1) :

Serial Communications 3107

<u>HOST (PLC)</u>		<u>SLAVE (3000)</u>
02H	→	
10H		
01H		
61H		
01H		
4DH		
B0H		
03H	→	

2. Message #98 : SEND A VARIABLE TO THE 3000

With this command, the master sends registers to the slave unit.

QUERY MESSAGE

Begin of frame	STX	02
	DLE	10H
Address	xxx	xxx
Code	98	62H
Stamp	xxx	xxx
Data	Address	1WORD
	WordCount	1WORD
	DATA	WordCount WORDS
Error check	xxxxxx	
End of frame	ETX	03

RESPONSE MESSAGE

Begin of frame	STX	02
	DLE	10H
Address	xxx	xxx
Code	98	62H
Stamp	xxx	xxx
Data	Address	1WORD
	WordCount	1WORD
	DATA	WordCount WORDS
Error check	xxx	xxx
End of frame	ETX	03

Example 1 :

The Host writes the batch setpoint :

Batch set point : 100.0 Tons

Address of Slave : 1

HOST (PLC) SLAVE

02H	→
10H	
01H	
62H	
01H	
00H	
69H	

```

00H
02H
42H
C8H
00H
00H
D9H
03H      →

                ←      02H
                        10H
                        01H
                        62H
                        01H
                        00H
                        69H
                        00H
                        02H
                        CFH
                ←      03H
    
```

3. Message #99 : READ REGISTER FROM THE 3000
 With this command, the master asks the slave unit for registers.

QUERY MESSAGE

Begin of frame	STX	02
	DLE	10H
Address	xxx	xxx
Code	99	63H
Stamp	xxx	xxx
Data	Address	1WORD
	WordCount	1WORD
Error check	xxx	xxx
End of frame	ETX	03

RESPONSE MESSAGE

Begin of frame	STX	02
	DLE	10H
Address	xxx	xxx
Code	99	63H
Stamp	xxx	xxx
Data	Address	1WORD
	WordCount	1WORD
	DATA	n. WORDS
Error check	xxx	xxx
End of frame	ETX	03

Example 1 :

The Host reads from the 3000 the batch setpoint :

Batch set point : 200.5 Tons

Address of Slave : 1

Serial Communications 3107

<u>HOST (PLC)</u>		<u>SLAVE (3000)</u>
02H	→	
10H		
01H		
63H		
01H		
00H		
69H		
00H		
02H		
D0H		
03H	→	
	←	02H
		10H
		01H
		63H
		01H
		00H
		69H
		00H
		02H
		43H
		48H
		80H
		00H
		DBH
	←	03H

3.6.2 Register Mapping for PC-Master Protocol

register	address	note
success_flag	20 H	0 successful, 1 failed
display(1)	21 H	
display(2)	22 H	
display(3)	23H	
display(4)	24 H	
display(5)	25 H	
display(6)	26 H	
display(7)	27 H	
display(8)	28 H	
display(9)	29 H	
display(10)	2A H	
display(11)	2B H	
display(12)	2C H	
display(13)	2D H	
display(14)	2E H	
display(15)	2F H	
display(16)	30 H	
display(17)	31 H	
display(18)	32 H	
display(19)	33 H	
display(20)	34 H	
display(21)	35 H	
display(22)	36 H	
display(23)	37 H	
display(24)	38 H	
display(25)	39 H	
display(26)	3A H	
display(27)	3B H	
display(28)	3C H	
display(29)	3D H	
display(30)	3E H	
display(31)	3F H	
display(32)	40 H	
display(33)	41 H	
display(34)	42 H	
display(35)	43 H	
display(36)	44 H	
display(37)	45 H	
display(38)	46 H	
display(39)	47 H	
display(40)	48 H	
leds	49 H	
status(1)	4A H	
status(2)	4B H	
alarm_status(1)	4C H	
alarm_status(2)	4D H	
alarm_status(3)	4E H	
i_o(1)	4F H	
i_o(2)	50H	
i_o(3)	51 H	

Serial Communications 3107

i_o(4)	52 H	
i_o(5)	53 H	
i_o(6)	54 H	
i_o(7)	55 H	
i_o(8)	56 H	
i_o(9)	57 H	
i_o(10)	58 H	
i_o(11)	59 H	
i_o(12)	5A H	
commands	5B H	
batch_number	5C H	Load out option required
batch_deviation	5D H	Load out option required
product number	5E H	
percent of ingred._1	5F H	
percent of ingred._2	60 H	
rate(1)	61 H	
rate(2)	62 H	
master_total(1)	63 H	
master_total(2)	64 H	
reset_total(1)	65 H	
reset_total(2)	66 H	
operator_total(1)	67 H	
operator_total(2)	68 H	
batch_total(1)	69 H	Load out option required
batch_total(2)	6A H	Load out option required
batch_set_point(1)	6B H	Load out option required
batch_set_point(2)	6C H	Load out option required
batch_pre_set(1)	6D H	Load out option required
batch_pre_set(2)	6E H	Load out option required
preset set point(1)	6F H	Load out option required
preset set point(2)	70 H	Load out option required
batch_pre_act(1)	71 H	Load out option required
batch_pre_act(2)	72 H	Load out option required
scale_capacity(1)	73 H	

scale_capacity(2)	74 H	
high_rate_set(1)	75 H	
high_rate_set(2)	76 H	
low_rate_set(1)	77 H	
low_rate_set(2)	78 H	
reg_set_point_1(1)	79H	
reg_set_point_1(2)	7A H	
reg_set_point_2(1)	7B H	
reg_set_point_2(2)	7C H	
dsp_set_point_1(1)	7D H	
dsp_set_point_1(2)	7E H	
dsp_set_point_2(1)	7F H	
dsp_set_point_2(2)	80 H	
ctr_deviation_1(1)	81 H	
ctr_deviation_1(2)	82 H	
ctr_deviation_2(1)	83 H	
ctr_deviation_2(2)	84 H	
hi_pos_dev_1(1)	85 H	
hi_pos_dev_1(2)	86 H	
hi_hi_pos_dev_1(1)	87 H	
hi_hi_pos_dev_1(2)	88 H	
hi_neg_dev_1(1)	89 H	
hi_neg_dev_1(2)	8A H	
hi_hi_neg_dev_1(1)	8B H	
hi_hi_neg_dev_1(2)	8C H	
hi_pos_dev_2(1)	8D H	
hi_pos_dev_2(2)	8E H	
hi_hi_pos_dev_2(1)	8F H	
hi_hi_pos_dev_2(2)	90 H	
hi_neg_dev_2(1)	91 H	
hi_neg_dev_2(2)	92 H	

hi_hi_neg_dev_2(1)	93 H	
hi_hi_neg_dev_2(2)	94 H	

3.7 Siemens 3964R

3.7.1 Description

The protocol has been implemented as described in – “Funzioni di accoppiamento con CP 525/2 Manuale – Simatic S5” – Siemens.

Two communication modes are provided :

FETCH The HOST asks the slave unit for register

SEND The HOST sends registers to the slave

The choice between requesting or sending data is made using a specific code inside the message.

- The Host (PLC) sends data to the Slave (3000) :

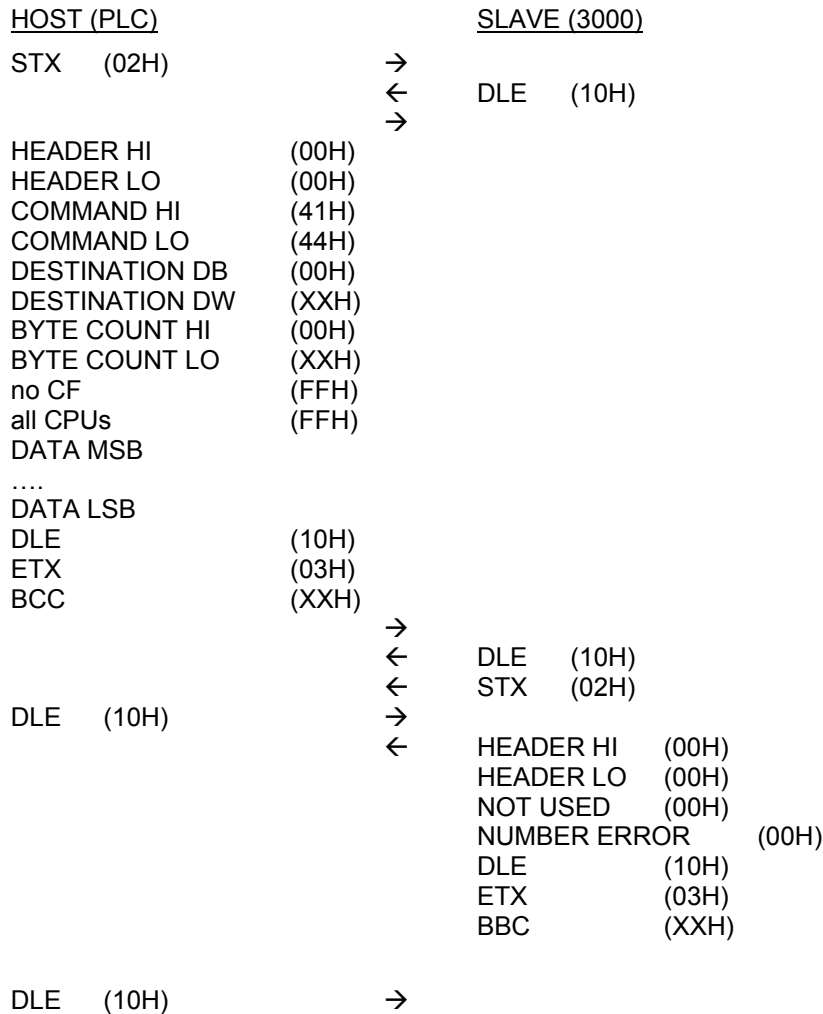

- The Host (PC or PLC) asks for data from the Slave (3000) :

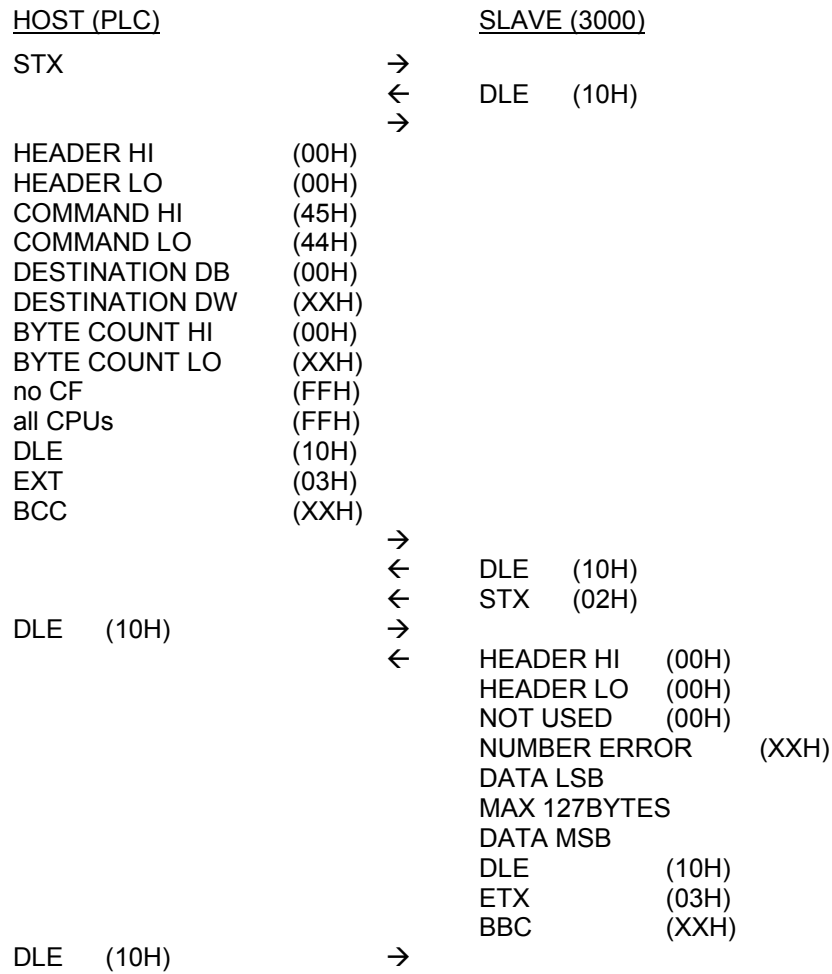

Example 1 :

The Host wants to write the batch set point :

Set batch : 100.0 Tons

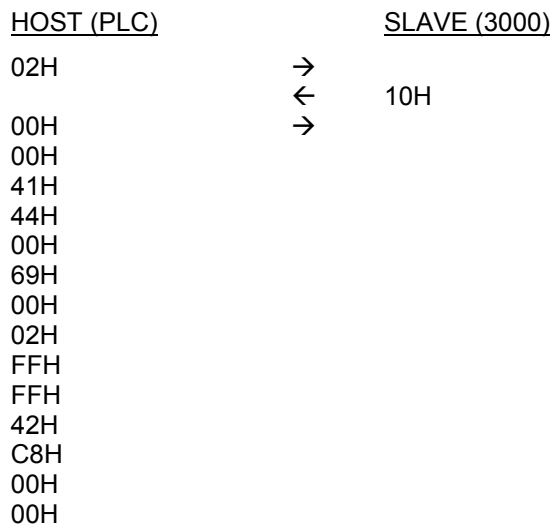

Serial Communications 3107

```
10H
03H
F7H      →
          ← 10H
          ← 02H
10H      →
          ← 00H
          00H
          00H
          00H
          10H
          03H
          13H
10H      →
```

Example 2 :

The Host wants to receive the batch set point :

Batch set point: 100.0 Tons

```
HOST (PLC)           SLAVE (3000)
02H                →
                  ← 10H
00H                →
00H
45H
44H
00H
69H
00H
02H
FFH
FFH
10H
03H
79H                →
                  ← 10H
                  ← 02H
10H                →
                  ← 00H
                  00H
                  00H
                  00H
                  42H
                  C8H
                  00H
                  00H
                  10H
                  03H
                  99H
10H                →
```

3.7.2 Register Mapping for Siemens 3964R Protocol

register	address	note
success_flag	20 H	0 successful, 1 failed
display(1)	21 H	
display(2)	22 H	
display(3)	23 H	
display(4)	24 H	
display(5)	25 H	
display(6)	26 H	
display(7)	27 H	
display(8)	28 H	
display(9)	29 H	
display(10)	2A H	
display(11)	2B H	
display(12)	2C H	
display(13)	2D H	
display(14)	2E H	
display(15)	2F H	
display(16)	30 H	
display(17)	31 H	
display(18)	32 H	
display(19)	33 H	
display(20)	34 H	
display(21)	35 H	
display(22)	36 H	
display(23)	37 H	
display(24)	38 H	
display(25)	39 H	
display(26)	3A H	
display(27)	3B H	
display(28)	3C H	
display(29)	3D H	
display(30)	3E H	
display(31)	3F H	
display(32)	40 H	
display(33)	41 H	
display(34)	42 H	
display(35)	43 H	
display(36)	44 H	
display(37)	45 H	
display(38)	46 H	
display(39)	47 H	
display(40)	48 H	
leds	49 H	
status(1)	4A H	
status(2)	4B H	
alarm_status(1)	4C H	
alarm_status(2)	4D H	
alarm_status(3)	4E H	
i_o(1)	4F H	
i_o(2)	50 H	
i_o(3)	51 H	

Serial Communications 3107

i_o(4)	52 H	
i_o(5)	53 H	
i_o(6)	54 H	
i_o(7)	55 H	
i_o(8)	56 H	
i_o(9)	57 H	
i_o(10)	58 H	
i_o(11)	59 H	
i_o(12)	5A H	
commands	5B H	
batch_number	5C H	Load out option required
batch_deviation	5D H	Load out option required
product number	5E H	
percent of ingred._1	5F H	
percent of ingred._2	60 H	
rate(1)	61 H	
rate(2)	62 H	
master_total(1)	63 H	
master_total(2)	64 H	
reset_total(1)	65 H	
reset_total(2)	66 H	
operator_total(1)	67 H	
operator_total(2)	68 H	
batch_total(1)	69 H	Load out option required
batch_total(2)	6A H	Load out option required
batch_set_point(1)	6B H	Load out option required
batch_set_point(2)	6C H	Load out option required
batch_pre_set(1)	6D H	Load out option required
batch_pre_set(2)	6E H	Load out option required
preset set point(1)	6F H	Load out option required
preset set point(2)	70 H	Load out option required
batch_pre_act(1)	71 H	Load out option required
batch_pre_act(2)	72 H	Load out option required
scale_capacity(1)	73 H	
scale_capacity(2)	74 H	

high_rate_set(1)	75 H	
high_rate_set(2)	76 H	
low_rate_set(1)	77 H	
low_rate_set(2)	78 H	
reg_set_point_1(1)	79H	
reg_set_point_1(2)	7A H	
reg_set_point_2(1)	7B H	
reg_set_point_2(2)	7C H	
dsp_set_point_1(1)	7D H	
dsp_set_point_1(2)	7E H	
dsp_set_point_2(1)	7F H	
dsp_set_point_2(2)	80 H	
ctr_deviation_1(1)	81 H	
ctr_deviation_1(2)	82 H	
ctr_deviation_2(1)	83 H	
ctr_deviation_2(2)	84 H	
hi_pos_dev_1(1)	85 H	
hi_pos_dev_1(2)	86 H	
hi_hi_pos_dev_1(1)	87 H	
hi_hi_pos_dev_1(2)	88 H	
hi_neg_dev_1(1)	89 H	
hi_neg_dev_1(2)	8A H	
hi_hi_neg_dev_1(1)	8B H	
hi_hi_neg_dev_1(2)	8C H	
hi_pos_dev_2(1)	8D H	
hi_pos_dev_2(2)	8E H	
hi_hi_pos_dev_2(1)	8F H	
hi_hi_pos_dev_2(2)	90 H	
hi_neg_dev_2(1)	91 H	
hi_neg_dev_2(2)	92 H	
hi_hi_neg_dev_2(1)	93 H	

Serial Communications 3107

hi_hi_neg_dev_2(2)	94 H	
----------------------	------	--

3.8 Modbus

3.8.1 Description

This protocol has been implemented as described in : - "Gould Modicon Modbus Protocol" – Reference Guide – November 1993 – Rev.A (Gould Inc. Programmable Control Division).

NOTE: Only a subset of the protocol has been implemented, as described in this chapter.

- Message of data query from host (PC or PLC) to Slave (3000) (code 03H)

QUERY

Address	xxx
function	03H
add.hi	xxx
add.lo	xxx
n.data hi	xxx
n.data lo	xxx
crc16 lo	xxx
crc16 hi	xxx

REPONSE MESSAGE

Address	xxx
function	03H
byte cnt	xxx
data MSB	xxx
...	xxx
data LSB	xxx
crc16 lo	xxx
crc16 hi	xxx

Example 1 :

The Host wants to receive the batch set point :

Set point : 100.0 Tons

Address of Slave: 01

<u>HOST (PLC)</u>		<u>SLAVE (3000)</u>
01H	→	
03H		
00H		
69H		
00H		
02H		
04H		
17H	→	
	←	01H
		03H
		04H

Serial Communications 3107

00H
00H
42H
C8H
CBH
← 05H

- Message of data sending from host (PC or PLC) to Slave (3000) (code 10H)

QUERY

Address	xxx
function	10H
add.hi	xxx
add.lo	xxx
n.data hi	xxx
n.data lo	xxx
n. bytes	xxx
data MSB	xxx
...	xxx
data LSB	xxx
crc16 lo	xxx
crc16 hi	xxx

REPONSE MESSAGE

Address	xxx
function	10H
add. hi	xxx
add. lo	xxx
n. data hi	xxx
n. data lo	xxx
crc16 lo	xxx
crc16 hi	xxx

Example 1 :

The Host wants to write the batch set point :

Batch Set point : 100.0 Tons

Address of Slave: 1

HOST (PLC) SLAVE (3000)

01H →
10H
00H
69H
00H
02H
04H
00H
00H
42H
C8H

5CH
00H
00H
49H
D8H
←

3.8.2 Register Mapping for Modbus

register	address	note
success_flag	33	0 successful, 1 failed
display(1)	34	
display(2)	35	
display(3)	36	
display(4)	37	
display(5)	38	
display(6)	39	
display(7)	40	
display(8)	41	
display(9)	42	
display(10)	43	
display(11)	44	
display(12)	45	
display(13)	46	
display(14)	47	
display(15)	48	
display(16)	49	
display(17)	50	
display(18)	51	
display(19)	52	
display(20)	53	
display(21)	54	
display(22)	55	
display(23)	56	
display(24)	57	
display(25)	58	
display(26)	59	
display(27)	60	
display(28)	61	
display(29)	62	
display(30)	63	
display(31)	64	
display(32)	65	
display(33)	66	
display(34)	67	
display(35)	68	
display(36)	69	
display(37)	70	
display(38)	71	
display(39)	72	
display(40)	73	
leds	74	
status(1)	75	
status(2)	76	

alarm_status(1)	77	
alarm_status(2)	78	
alarm_status(3)	79	
i_o(1)	80	
i_o(2)	81	
i_o(3)	82	
i_o(4)	83	
i_o(5)	84	
i_o(6)	85	
i_o(7)	86	
i_o(8)	87	
i_o(9)	88	
i_o(10)	89	
i_o(11)	90	
i_o(12)	91	
commands	92	
batch_number	93	Load out option required
batch_deviation	94	Load out option required
product number	95	
percent of ingred._1	96	
percent of ingred._2	97	
rate(1)	98	
rate(2)	99	
master_total(1)	100	
master_total(2)	101	
reset_total(1)	102	
reset_total(2)	103	
operator_total(1)	104	
operator_total(2)	105	
batch_total(1)	106	Load out option required
batch_total(2)	107	Load out option required
batch_set_point(1)	108	Load out option required
batch_set_point(2)	109	Load out option required
batch_pre_set(1)	110	Load out option required
batch_pre_set(2)	111	Load out option required
preset set point(1)	112	Load out option required
preset set point(2)	113	Load out option required
batch_pre_act(1)	114	Load out option required

Serial Communications 3107

batch_pre_act(2)	115	Load out option required
scale_capacity(1)	116	
scale_capacity(2)	117	
high_rate_set(1)	118	
high_rate_set(2)	119	
low_rate_set(1)	120	
low_rate_set(2)	121	
reg_set_point_1(1)	122	
reg_set_point_1(2)	123	
reg_set_point_2(1)	124	
reg_set_point_2(2)	125	
dsp_set_point_1(1)	126	
dsp_set_point_1(2)	127	
dsp_set_point_2(1)	128	
dsp_set_point_2(2)	129	
ctr_deviation_1(1)	130	
ctr_deviation_1(2)	131	
ctr_deviation_2(1)	132	
ctr_deviation_2(2)	133	
hi_pos_dev_1(1)	134	
hi_pos_dev_1(2)	135	
hi_hi_pos_dev_1(1)	136	
hi_hi_pos_dev_1(2)	137	
hi_neg_dev_1(1)	138	
hi_neg_dev_1(2)	139	
hi_hi_neg_dev_1(1)	140	
hi_hi_neg_dev_1(2)	141	
hi_pos_dev_2(1)	142	
hi_pos_dev_2(2)	143	
hi_hi_pos_dev_2(1)	144	
hi_hi_pos_dev_2(2)	145	

hi_neg_dev_2(1)	146	
hi_neg_dev_2(2)	147	
hi_hi_neg_dev_2(1)	148	
hi_hi_neg_dev_2(2)	149	

3.9 Allen-Bradley DF1 (PLC-5)

3.9.1 Description

The DF1 is a proprietary protocol of Allen-Bradley. The protocol has been implemented according to : Allen-Bradley "Reference Manual–Data Highway / Data Highway Plus Protocol and Command Set".Pubblicat. 1770-6.5,16 September 1991.

WARNING

ONLY A SUBSET OF THE PROTOCOL HAS BEEN IMPLEMENTED. THE COMMANDS USED TO READ OR WRITE THE REGISTERS ARE : TYPED READ (CODE 68H) AND TYPED WRITE (67H).

- Connect message

This message must be sent from Host to Slave before a request of sending data can be performed.

<u>HOST (PLC)</u>		<u>SLAVE (3000)</u>
DLE	(10H)	→
SOH	(01H)	
ADDRESS OF SLAVE		
DLE	(10H)	
STX	(02H)	
ADDRESS OF SLAVE		
ADDRESS OF HOST		
COMMAND	(OF H)	
STS	(00H)	
TMS	(xxH)	
TMS	(xxH)	
FNC	(68 H)	
PACKET OFFSET (LOW)		
PACKET OFFSET (HIGHT)		
TOTAL TRANS (LOW)		
TOTAL TRANS (HIGH)		
ADDRESS OF DATA (FIRST BYTE)		
ADDRESS OF DATA (SECOND BYTE)		
ADDRESS OF DATA (THIRD BYTE)		
ADDRESS OF DATA (FOURTH BYTE)		
SIZE OF DATA IN ELEMENTS (LOW)		
SIZE OF DATA IN ELEMENTS (HIGH)		
DLE	(10H)	
ETX	(03H)	
BCC		→
		← DLE (10H)
		← ACK (06H)

- The HOST (PLC) asks for data from the Slave (3000) :
This message is sent from the Host to the Slave to request a certain number of data:

<u>HOST (PLC)</u>		<u>SLAVE (3000)</u>
DLE (10H)	→	
ENQ (05H)		
ADDRESS SLAVE		
BCC	→	
	←	DLE (10H)
		STX (02H)
		ADDRESS HOST
		ADDRESS SLAVE
		4FH (COMMAND)
		STS (00H)
		TMS (xxH)
		TMS (xxH)
		TYME DATA PARAMETER
		DATA LSB MSB
	
		DATA LSB MSB
		DLE (10H)
		ETX (03H)
	←	BCC
DLE (10H)	→	
ACK (06H)	→	

- The HOST (PLC) sends data to the Slave (3000) :
This message is used from the Host to the Slave to download registers into the Slave unit.

<u>HOST (PLC)</u>		<u>SLAVE (3000)</u>
DLE (10H)	→	
SOH (01H)		
ADDRESS SLAVE		
DLE (10H)		
STX (02H)		
ADDRESS SLAVE		
ADDRESS HOST		
COMMAND (OFH)		
STS (00H)		
TMS (xxH)		
TMS (xxH)		
FNC (67 H)		
PACKET OFFSET (LOW)		
PACKET OFFSET (HIGH)		
TOTAL TRANS (LOW)		
TOTAL TRANS (HIGH)		
ADDRESS OF DATA (FIRST BYTE)		
ADDRESS OF DATA (SECOND BYTE)		
ADDRESS OF DATA (THIRD BYTE)		
ADDRESS OF DATA (FOURTH BYTE)		
TYPE DATA PARAMETER		

Serial Communications 3107

```

DATA LSB MSB
.....
DATA LSB MSB
DLE          (10H)
ETX          (03H)
BCC

                                →
                                ←   DLE          (10H)
                                ←   ACK          (06H)

```

- The HOST (PLC) asks the Slave (3000) if data were received o.k. :

```

HOST (PLC)                SLAVE (3000)
DLE          (10H)           →
ENQ          (05H)
ADDRESS OF SLAVE
BCC

                                →
                                ←   DLE   (10H)
                                ←   STX   (02H)
                                ←   ADDRESS OF HOST
                                ←   ADDRESS OF SLAVE
                                ←   4FH   (COMMAND)
                                ←   STS   (00H)
                                ←   TMS   (xxH)
                                ←   TMS   (xxH)
                                ←   DLE   (10H)
                                ←   ETX   (03H)
                                ←   BCC

DLE          (10H)           →
ACK          (06H)           →

```

If the message is incorrectly received, the instrument does not respond.
 The character 10H is doubled (sent two times), but it is computed once only in the BCC.

Example 1 :

The Host asks the instrument to send back the batch set point :

Set point : 200.5 Tons

Address of Slave: 01

Address of Host: 02

```

HOST (PLC)                SLAVE (3000)
10H          →
01H
01H
10H
02H
01H
02H
0FH
00H
00H

```

00H		
68H		
00H		
00H		
01H		
00H		
07H		
00H		
08H		
05H		
01H		
00H		
10H		
03H		
6FH	→	
	←	10H
	←	06H
10H	→	
05H		
01H		
FFH	→	
	←	10H
		02H
		02H
		01H
		4FH
		00H
		00H
		00H
		99H
		09H
		06H
		94H
		08H
		00H
		80H
		48H
		43H
		10H
		03H
		5FH
	←	
10H	→	
06H	→	

		00H
		00H
		00H
		10H
		03H
	←	AEH
10H	→	
06H	→	

3.9.2 Register Mapping for DF1 Allen-Bradley (PLC-5)

register	address	note
success_flag	N7:0	0 successful, 1 failed
display(1)	N7:1	
display(2)	N7:2	
display(3)	N7:3	
display(4)	N7:4	
display(5)	N7:5	
display(6)	N7:6	
display(7)	N7:7	
display(8)	N7:8	
display(9)	N7:9	
display(10)	N7:10	
display(11)	N7:11	
display(12)	N7:12	
display(13)	N7:13	
display(14)	N7:14	
display(15)	N7:15	
display(16)	N7:16	
display(17)	N7:17	
display(18)	N7:18	
display(19)	N7:19	
display(20)	N7:20	
display(21)	N7:21	
display(22)	N7:22	
display(23)	N7:23	
display(24)	N7:24	
display(25)	N7:25	
display(26)	N7:26	
display(27)	N7:27	
display(28)	N7:28	
display(29)	N7:29	
display(30)	N7:30	
display(31)	N7:31	
display(32)	N7:32	
display(33)	N7:33	
display(34)	N7:34	
display(35)	N7:35	
display(36)	N7:36	
display(37)	N7:37	
display(38)	N7:38	
display(39)	N7:39	
display(40)	N7:40	
leds	N7:41	
status(1)	N7:42	
status(2)	N7:43	
alarm_status(1)	N7:44	
alarm_status(2)	N7:45	
alarm_status(3)	N7:46	
i_o(1)	N7:47	
i_o(2)	N7:48	
i_o(3)	N7:49	

i_o(4)	N7:50	
i_o(5)	N7:51	
i_o(6)	N7:52	
i_o(7)	N7:53	
i_o(8)	N7:54	
i_o(9)	N7:55	
i_o(10)	N7:56	
i_o(11)	N7:57	
i_o(12)	N7:58	
commands	N7:59	
batch_number	N7:60	Load out option required
batch_deviation	N7:61	Load out option required
product_number	F7:62	
percent of ingred._1	N7:63	
percent of ingred._2	N7:64	
rate	F8:0	
master_total	F8:1	
reset_total	F8:2	
operator_total	F8:3	
batch_total	F8:4	Load out option required
batch_set_point	F8:5	
batch_pre_set	F8:6	Load out option required
preset set point	F8:7	
batch_pre_act	F8:8	Load out option required
scale_capacity	F8:9	
high_rate_set	F8:10	
low_rate_set	F8:11	
reg_set_point_1	F8:12	
reg_set_point_2	F8:13	
dsp_set_point_1	F8:14	
dsp_set_point_2	F8:15	
ctr_deviation_1	F8:16	
ctr_deviation_2	F8:17	
hi_pos_dev_1	F8:18	
hi_hi_pos_dev_1	F8:19	
hi_neg_dev_1	F8:20	

Serial Communications 3107

hi_hi_neg_dev_1	F8:21	
hi_pos_dev_2	F8:22	
hi_hi_pos_dev_2	F8:23	
hi_neg_dev_2	F8:24	
hi_hi_neg_dev_2	F8:25	

Chapter 4 Maintenance

4.1 General

Refer to the Micro-Tech 3000 Integrator manual for maintenance information.

Chapter 5 Parts

5.1 General

Refer to the Micro-Tech 3000 Integrator manual for parts information.