

# PROFIBUS-DP Slave Protocol Manual

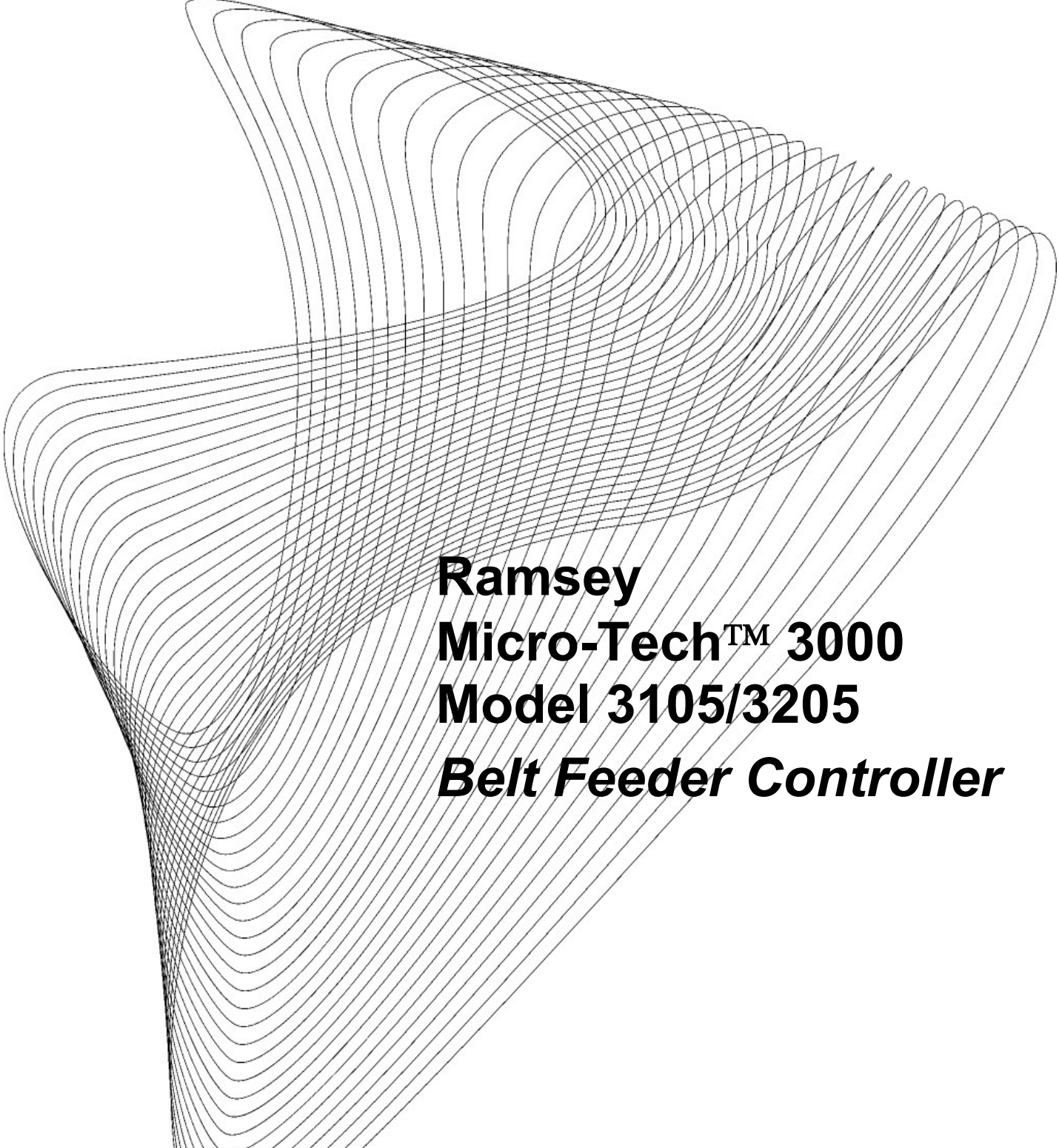

**Ramsey**  
**Micro-Tech™ 3000**  
**Model 3105/3205**  
***Belt Feeder Controller***

PROFIBUS-  
3105/3205 Rev  
Part No.: XXXXX

**Thermo**  
ELECTRON CORPORATION



# Ramsey Micro-Tech™ 3000 Profibus-DP Model 3105/3205 Belt Feeder Controller

This document is confidential and is the property of *Thermo Electron*. It may not be copied or reproduced in any way without the express written consent of *Thermo Electron*. This document also is an unpublished work of *Thermo Electron*. *Thermo Electron* intends to, and is maintaining the work as confidential information. *Thermo Electron* also may seek to protect this work as an unpublished copyright. In the event of either inadvertent or deliberate publication, *Thermo Electron* intends to enforce its rights to this work under the copyright laws as a published work. Those having access to this work may not copy, use, or disclose the information in this work unless expressly authorized by *Thermo Electron*.

*All registered and unregistered trademarks are the property of their respective owners.*



**Thermo Electron,**  
501 90th Avenue N.W.  
Minneapolis, MN 55433 U.S.A.  
Tel (763) 783-2500  
Fax (763) 783-2525  
<http://www.thermoelectron.com>  
[eng@thermoelectron.com](mailto:eng@thermoelectron.com)  
2003 Thermo Electron

**Thermo**  
ELECTRON CORPORATION

## **Revision History**

Preliminary      December 2003      Manual first released

# Table of Contents

Table of Contents .....	i
List of Figures .....	iii
List of Tables .....	iv
Chapter 1 Introduction .....	1-1
1.1 General.....	1-1
1.2 Profibus-DP .....	1-1
1.3 Data Transfer .....	1-1
1.4 Protection Mechanisms.....	1-1
1.5 Thermo Electron Warranty.....	1-1
Disclaimer.....	1-2
Chapter 2 Installation.....	2-1
2.1 General.....	2-1
2.2 Profibus-DP Interface Board.....	2-1
2.2.1. Cable Type and Length.....	2-1
2.3 Profibus-DP Connector .....	2-2
2.3.1. Bus Connector Wiring .....	2-3
2.3.2. Termination Power.....	2-3
2.4 Profibus-DP Board Installation.....	2-3
Chapter 3 Operation .....	3-1
3.1 General.....	3-1
3.2 Micro-Tech 3000 Configuration .....	3-1
3.2.1 Slave Address and Buffer Dimensions.....	3-1
3.2.2 PROFIB Scroll .....	3-1
3.2.3 Baud Rate .....	3-2
3.3 Data Transfer .....	3-3
3.3.1 Write Operation.....	3-3
3.3.2 Read Operation .....	3-5
3.4 Timings.....	3-6
3.5 Communication Error .....	3-6
3.5.1 Diagnostic Data .....	3-6
3.6 Description of the Variable.....	3-8
3.6.1 Legend .....	3-8
3.6.2 Calibration Commands .....	3-12
3.6.3 Batch Commands .....	3-13
3.6.4 Reset Commands .....	3-13
3.7 Read Group Composition .....	3-19
3.7.1 Read Group 0 – Dynamic Variables and Status .....	3-19
3.7.2 Read Group 1 – Load Out .....	3-20
3.7.3 Read Group 2 – Sets and Thresholds.....	3-20
3.7.4 Read Group 3 – Display .....	3-21
3.8 Write Group Composition .....	3-23

**Profibus-DP Model 3105/3205**

3.8.1	Write Group 100 - Commands .....	3-23
3.8.2	Write Group 101 – Load Out .....	3-23
3.8.3	Write Group 102 – Set and Thresholds.....	3-24
Appendix A	Floating Point Notation.....	A-1
Appendix B	The GSD File.....	B-1

## List of Figures

Figure 2-1	Profibus-DP Interface Board	2-1
Figure 2-2	Micro-Tech 3000 Mother Board	2-4

## List of Tables

Table 2-1:	Maximum Cable Length of a Segment (Standard Lane Cable)	2-2
Table 2-2:	Maximum Cable Length between two Nodes (Standard Lane Cables)	2-2
Table 2-3:	Bus Connector	2-3
Table 3-1:	Composition of the Write Package	3-4
Table 3-2:	Composition of the Read Buffer after Power ON	3-5
Table 3-3:	Composition of the Diagnostic Data	3-6
Table 3-4:	Variables and their Characteristics	3-9
Table 3-5:	Key Codes	3-17
Table 3-6:	Read Group 0 [VAT1]	3-19
Table 3-7:	Read Group 1 [VAT2]	3-20
Table 3-8:	Read Group 2 [VAT3]	3-20
Table 3-9:	Read Group 3 [VAT4]	3-21
Table 3-10:	Write Group 100 [VAT5]	3-23
Table 3-11:	Write Group 101 [VAT6]	3-23
Table 3-12:	Write Group 102 [VAT7]	3-24

# Chapter 1 Introduction

## 1.1 General

PROFIBUS was developed by the need to have an open, vendor independent communication system that allows connection to any components used in the automation of technical processes.

The PROFIBUS is a standardized communication system, all its characteristics, rules and technical information are collected in the PROFIBUS DIN normative.

There are three main variations of PROFIBUS corresponding to the intended application: PROFIBUS-FMS, PROFIBUS-DP and PROFIBUS-PA. The Micro-Tech 3000 variation is PROFIBUS-DP.

## 1.2 Profibus-DP

PROFIBUS-DP is the performance optimized version specifically dedicated to time-critical communication between automation systems and distributed peripherals.

It is typically used to transfer I/O images between a main PLC and remote devices (sensors, actuators, transmitters, etc.). In this case, it will be used to transfer (read and write) blocks of data.

PROFIBUS is a typical master/slave communication where the main PLC is the master or scanner, and the Micro-Tech 3000's are slaves. The connection is EIA RS 485 through a 2-wire twinax Siemens cable.

## 1.3 Data Transfer

The interface between the master and slaves is structured in parameterization, configuration, and data transfer phase. In the parameterization and configuration phases, each slave compares its real configuration with the configuration data received from the master. When verifying the configuration, device type, format and length of information have to be identical. This guarantees a protection against a configuration fault. Maximum number of data that is possible to transfer in this phase at one time is limited to 246 bytes (123 words).

## 1.4 Protection Mechanisms

Besides the configuration, check to avoid erroneous configurations, the slave uses the watch dog control to detect failures on the bus. If a slave recognizes no successful data transfer with the master within the watch dog control interval, it generates an alarm condition.

## 1.5 Thermo Electron Warranty

The seller agrees, represents, and warrants that the equipment delivered hereunder shall be free from defects in material and workmanship. Such warranty shall not apply to accessories, parts, or material purchased by the seller unless they are manufactured pursuant to seller's design, but shall apply to the workmanship incorporated in the installation of such items in the complete equipment. To the extent purchased parts or accessories are covered by the manufacturer's warranty, seller shall extend such warranty to buyer.

Seller's obligation under said warranty is conditioned upon the return of the defective equipment, transportation charges prepaid, to the seller's factory in Minneapolis, Minnesota, and the submission of reasonable proof to seller prior

to return of the equipment that the defect is due to a matter embraced within seller's warranty hereunder. Any such defect in material and workmanship shall be presented to seller as soon as such alleged errors or defects are discovered by purchaser and seller is given opportunity to investigate and correct alleged errors or defects and in all cases, buyer must have notified seller thereof within one (1) year after delivery, or one (1) year after installation if the installation was accomplished by the seller.

Said warranty shall not apply if the equipment shall not have been operated and maintained in accordance with seller's written instructions applicable to such equipment, or if such equipment shall have been repaired or altered or modified without seller's approval; provided, however, that the foregoing limitation of warranty insofar as it relates to repairs, alterations, or modifications, shall not be applicable to routine preventive and corrective maintenance which normally occur in the operation of the equipment.

“EXCEPT FOR THOSE WARRANTIES SPECIFICALLY CONTAINED HEREIN, SELLER DISCLAIMS ANY AND ALL WARRANTIES WITH RESPECT TO THE EQUIPMENT DELIVERED HEREUNDER, INCLUDING THE IMPLIED WARRANTIES OF MERCHANTABILITY AND FITNESS FOR USE. THE SOLE LIABILITY OF SELLER ARISING OUT OF THE WARRANTY CONTAINED HEREIN SHALL BE EXCLUSIVELY LIMITED TO BREACH OF THOSE WARRANTIES. THE SOLE AND EXCLUSIVE REMEDY FOR BREACH OF THE WARRANTIES SET OUT ABOVE SHALL BE LIMITED TO THE REPAIR OR REPLACEMENT OF ANY DEFECTIVE ACCESSORY, PART OR MATERIAL WITH A SIMILAR ITEM FREE FROM DEFECT, AND THE CORRECTION OF ANY DEFECT IN WORKMANSHIP. IN NO EVENT SHALL SELLER BE LIABLE FOR ANY INCIDENTAL OR CONSEQUENTIAL DAMAGES.”

Purchaser agrees to underwrite the cost of any labor required for replacement; including time, travel, and living expenses of *Thermo Electron Field Service* Engineer at closest factory base.

**THERMO ELECTRON**  
**501 90<sup>TH</sup> AVE. NW**  
**MINNEAPOLIS, MN 55433**  
**PHONE: (763) 783-2500**  
**FAX: (763) 783-2525**

## **Disclaimer**

Though the information provided herein is believed to be accurate, be advised that the information contained herein is *not* a guarantee for satisfactory results. Specifically, this information is neither a warranty nor guarantee, expressed or implied, regarding performance, merchantability, fitness, or any other matter with respect to the products, and recommendation for use of the product/process information in conflict with any patent. Please note that *Thermo Electron* reserves the right to change and/or improve the product design and specifications without notice.

## Chapter 2 Installation

### 2.1 General

This chapter describes the installation procedure and hardware configuration for the PROFIBUS-DP interface option. If the PROFIBUS-DP option was installed at the factory, skip to Section 2.3.

### 2.2 Profibus-DP Interface Board

The PROFIBUS-DP interface board (Figure 2-1) contains the Siemens SPC3 PROFIBUS-DP controller ASIC. The SPC3 controller is an integrated circuit provided by Siemens that handles the interface between the Micro-Tech 3000 (slave) and the master.

No hardware configuration jumpers or switches are present on the PROFIBUS-DP board.

Figure 2-1 Profibus-DP Interface Board

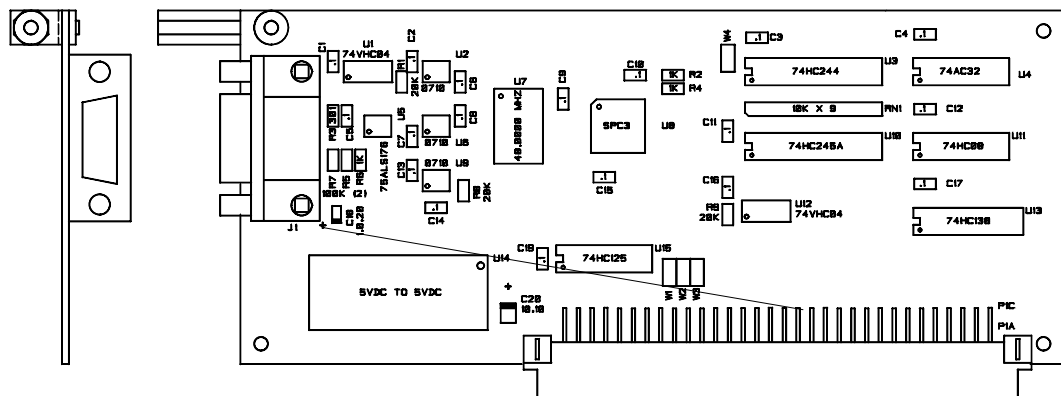

A01761

#### 2.2.1. Cable Type and Length

##### Application

Different types of cables are available from Siemens for various applications when assembling PROFIBUS networks. Standard Siemens PROFIBUS LAN cable number 6XV1 830-0AH10 is available from Thermo Ramsey, part number 057415.

Consult the Siemens PROFIBUS network manual 6GK1 970-5CA10-0AA1 for additional information.

##### RS 485 Repeater Application

An RS 485 repeater amplifies data signals on LAN cables and connects bus segments. An RS 485 repeater is required in the following situations:

1. When there are more than 32 stations connected to the bus.

2. When electrically isolated bus segments are required, or
3. When the maximum cable length of a segment (standard LAN cable) is exceeded (see Table 2-1).

**TABLE 2-1  
MAXIMUM CABLE LENGTH OF A SEGMENT (STANDARD LAN CABLE)**

Transmission Rate	Maximum Cable Length of a Segment (in m)
9.6 to 93.75 Kbps	1000
187.50 Kbps	800
500.00 Kbps	400
1.50 Mbps	200
3.0 to 12.00 Mbps	100

**Rules**

If you want to install the bus with RS 485 repeaters, the following rules apply:

1. A maximum of 9 RS 485 repeaters can be connected in series.
2. The maximum cable length between two nodes must not exceed the values in Table 2-2.

**TABLE 2-2  
MAXIMUM CABLE LENGTH BETWEEN TWO NODES (STANDARD LAN CABLES)**

Transmission Rate	Maximum Cable Length Between Two Nodes (in m) With RS 485 Repeater
9.6 to 93.75 Kbps	10000
187.50 Kbps	8000
500.00 Kbps	4000
1.50 Mbps	2000
3.0 to 12.00 Mbps	1000

### 2.3 Profibus-DP Connector

The bus connector should be rated for 12 Mbaud and contain a termination resistor that can be switched on or off. Siemens bus connector 6ES7 972-OBA20-OXAO is available from Thermo Ramsey, part number 057416.

### 2.3.1. Bus Connector Wiring

Refer to the information sheet supplied with the bus connector and Table 2-3.

**TABLE 2-3  
BUS CONNECTOR**

Bus Connector 9 Pin Sub "D"		SIEMENS LAN CABLE
1	Chassis Ground	Braided Shield
2	---	
3	RxD/TxD-P	Data Line B (Red)
4	Control-P (Receive/(not) Transmit)	
5	Data Ground	
6	Power (+5 VDC @ 100 mA max)	Supplied by Micro-Tech 3000
7	---	
8	RxD/TxD-N	Data Line A (Green)
9	---	

2. Connect the green and red cable wires to the screw terminal block located in the connector. The two pairs of terminals for signal wires A and B are identical.

The following scheme is recommended for a PROFIBUS LAN:

Terminal A: green wire

Terminal B: red wire

**NOTE:** The same wires (green or red) must always be connected to the same terminal A or B in all bus terminals and with all bus connections, and be uniform throughout the segment.

3. Insure the braided shield is making metal-to-metal contact with the connector guide.

### 2.3.2. Termination Power

Up to 100 mA of isolated 5 VDC is available on J1, pin 6 to power bus termination or PROFIBUS optical link plugs.

## 2.4 Profibus-DP Board Installation

To install the PROFIBUS-DP board, proceed as follows:

1. Open the Micro-Tech wall mount enclosure and turn off power at the mains, or remove panel mount enclosure from the panel and remove top cover, allowing access to the mother board.
2. Remove the hex head mounting screw from the connector end of the PROFIBUS-DP board (Figure 2-1).

3. Insert the PROFIBUS board in any available expansion slot on the mother board (see Figure 2-2).
4. Insert the hex head screw through the chassis and tighten.

**Figure 2-2 Micro-Tech 3000 Mother Board**

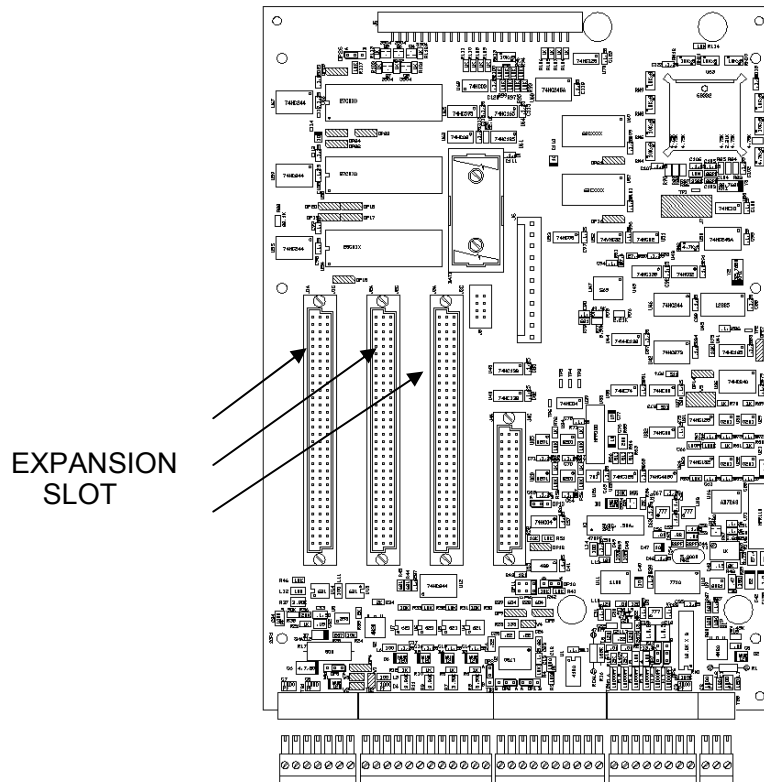

5. Replace the panel mount top cover and reinstall the panel mount enclosure in the control panel.
6. Install the wired mating connector on the PROFIBUS board.
7. Turn power back on at the mains. The following screen appears when power is restored and remains on for 10 seconds.

**-SLOT # N CHANGED**  
**Acquire new**  
**configuration?**  
**YES NO**

The screen disappears after ten seconds. If the question is not answered, the Micro-Tech 3000 assumes the answer is NO. HW (hardware) alarm is on and cannot be reset. The above screen appears each time power is cycled if the question is not answered.

Answer YES because this is a hardware configuration change.

Set-up data for the newly installed PROFIBUS-DP interface board must now be entered. Proceed to Chapter 3.0, Operation..

## Chapter 3 Operation

### 3.1 General

The Micro-Tech 3000 is a menu driven machine that allows the operator easy access to the PROFIBUS-DP set-up scroll in Main Menu 5.

### 3.2 Micro-Tech 3000 Configuration

Main Menu 5 is dedicated to the Micro-Tech 3000 communication options: COMM A serial communications, PROFIBUS-DP and PRINT. The PRINT scroll is only visible if the COMM A board is installed.

#### 3.2.1 Slave Address and Buffer Dimensions

The slave address and the buffer dimensions should be defined in the PROFIBUS scroll. Repeatedly press the MENU key until Main Menu 5 appears.

```
- MAIN MENU 5 -  
Press MENU for more  
  
COMMA PROFIB PRINT
```

#### 3.2.2 PROFIB Scroll

##### 1. Slave Address

Defines the address of the Micro-Tech 3000 in the PROFIBUS net. Press the soft key under PROFIB and scroll down.

```
- PROFIBUS SCROLL 1 -  
Address  
1  
ENTER
```

Password: SERVICE

Default: 1

Min: 1

Max: 126

Type in the address and press ENTER.

In the next two scrolls, the operator can define independently the read and write buffer dimensions. This feature is very useful since it allows reducing the address space to the minimum need.

The dimension should be entered in number of words. This number includes the header of the telegram taking four words (see Table 3-1), so the minimum is five words.

```
- PROFIBUS SCROLL 2 -  
  Read buffer dim.  
      48 words  
ENTER
```

Password: SERVICE

Default: 48

Min: 5

Max: 48

Type in the number of words and press ENTER. The following screen appears.

```
- PROFIBUS SCROLL 3 -  
  Write buffer dim.  
      48 words  
ENTER
```

Password: SERVICE

Default: 48

Min: 5

Max: 48

Type in the number of words and press ENTER. Press RUN to return to the RUN menu or MENU for more menus.

### 3.2.3 Baud Rate

The baud rate is automatically detected by the Micro-Tech 3000 and is displayed in Main Menu 3, TEST Scroll. Press the MENU key repeatedly until Main Menu 3 appears.

```
- MAIN MENU 3 -  
  Press menu for more  
  
  DIAG TEST
```

Press the TEST key and scroll down.

```
- TEST SCROLL 9 -  
  Test communication B  
  19.2 kb Wait Prm
```

The baud rate and status are dynamically displayed. The status can be:

WAIT PRM The Micro-Tech is waiting for the PARAMETER message.

WAIT CFG The Micro-Tech is waiting for the CONFIGURATION message.

DATA EXC The Micro-Tech is in the DATA EXCHANGE phase, configuration and parameterization have been completed successfully.



For example,

Hex 0102 read group 2, scale 2  
 Hex 0065 write group 101, scale 1

2. First Register Number

Registers in the groups are numbered from 0 to >n= and the master has the possibility to write only a portion of the registers composing the group. This parameter specifies the first register to write; 0 means the first register of the group.

3. Number of Registers to Write

This parameter specifies the number of register to write. It can be set to 0 to indicate all the registers of the group. In case the dimension of the write buffer is less then the length in words of the group, putting 0 here is the same as putting the group dimension minus 4 which is the length of the header.

4. Stamp

In the PROFIBUS protocol, data is transmitted continuously, so the same telegram is sent by the master to the slave several times. To avoid the slave interpreting the same data continuously (it would create problems; for example, with the commands), the stamp is used. The slave interprets received data only if the stamp is different from the stamp received in the previous telegram. The master has only to change the stamp value when it creates a new telegram. The stamp of the last interpreted telegram is re-transmitted by the Micro-Tech 3000 in the read buffer.

The >Data= section contains the data to write in the order MSB - LSB.

When the Micro-Tech 3000 processes the >package=, before writing the received data in the registers, it checks that all the parameters are correct (Example: Group ident. refers to an existing group). The data to write does not overlap specified maximum and minimum limits (each writeable register has its own maximum and minimum limit, see Table 3-4).

If it detects errors, the write operation fails and a DIAGNOSTICS message will be activated.

**TABLE 3-1 COMPOSITION OF THE WRITE PACKAGE**

Elem #	Register	Type	Offet (Words)	Note
1	Group Identifier	Integer	0	
2	First Register	Integer	2	
3	Nr of Register	Integer	3	
4	Stamp	Integer	1	
5	Data # 1		4	
...	.....		..	
...	Data #n		..	

### 3.3.2 Read Operation

In the PROFIBUS protocol, the master continuously reads data from the slave. Since the Micro-Tech 3000 has a large number of registers that can be sent to the master, the readable registers are collected in groups. Therefore, the master should have the possibility to tell the Micro-Tech 3000 what group and what registers of the group it needs to read.

It does it by performing a write operation, in the mode explained above, setting as >group identifier= the number of a read group. After the Micro-Tech 3000 receives and interprets this write request, it starts to fill the read buffer with the requested data.

**NOTE:** In a write operation, if the group identifier refers to a read group, only the header of the telegram is interpreted. The data is ignored.

The Micro-Tech 3000 will remember which registers have been required the last time and it will continue to update the read buffer with their actual values.

What the Master receives after a read operation is a buffer of data having the same structure of the write telegram (see Table 3-1). The first 4 words will contain the >group identifier=, >first register=, >number of register= and >stamp=, then the >data=.

After power on, the Micro-Tech 3000 starts to update the read buffer with the register of the read group 0 (scale 1). The master receives:

**TABLE 3-2 COMPOSITION OF THE READ BUFFER AFTER POWER ON**

Structure				Read Data	
Elem.#	Register	Type	Offset	Value	Note
1	Group Identifier	Integer	0	0	Ident for read group 0
2	First Register	Integer	1	0	From the first reg
3	Nr of registers	Integer	2	nnn	Number of word of the group 0, it depends by the MT model
4	Stamp	Integer	3	0	
5	Data # 1		4	xxx	Contents first reg.
...	.....		..	xxx	.....
nnn+5	Data # nn			xxx	Contents last reg.

In the Micro-Tech 3000, the group 0 is the >dynamic= group. It contains all the variables that change dynamically; for example, the actual weight or speed, the totalizers. Other groups contain set-up data; for example, the weight threshold set. Normally, the master will ask the group 0, only when necessary will it ask other groups.

### 3.4 Timings

The Micro-Tech 3000 updates almost all its basic variables (e.g.; weight, rate, totals) every 100 milliseconds. With the same frequency the Micro-Tech 3000 updates the read buffer. If the master performs more communications in this period, it will receive the same data more times.

The write request is interpreted by the Micro-Tech 3000 in polling with a period of 100 milliseconds.

### 3.5 Communication Error

The alarm condition >PROFIBUS comm error= is activated by the Micro-Tech 3000 in two conditions:

1. If the SPC3 controller installed on the >PROFIBUS interface board= does not recognize successful data transfer within the watch dog control interval.
2. If the received data contains errors (value overlaps limits, register number does not exist, group number does not exist).

The alarm can be defined as SHUT DOWN and the shut down digital output can be used to set the system in a safety condition.

In the second case, the Micro-Tech 3000 also activates an EXPANDED DIAGNOSTIC request to the master.

#### 3.5.1 Diagnostic Data

The master system has the possibility to detect a >communication error= condition by checking the diagnostics. In case of an error, the Micro-Tech 3000 will activate the request for diagnostic acquisition, indicating the expanded device related diagnostics data is present.

When the master requires the diagnostics, it receives:

**TABLE 3-3 COMPOSITION OF THE DIAGNOSTIC DATA**

Byte	Bit Position								Diagnostic Data
	7	6	5	4	3	2	1	0	
0									StatStatus1
1									StatStatus2
2									StatStatus3
3									MasterAdd
4									IdentNumberHigh
5									IdentNumberLow
6	0	0	0	0	0	0	1	0	Ext Diag - Header
7	0	0	0	0	GE	RE	LE	CE	Ext Diag - Data

*GE* Group Error Invalid group identifier, the group does not exists

*RE* Register number Error The number of request register is wrong.

*LE Limits Error* A write operation has been performed but the value to write overlaps the limits.

*CE Coherency Error* The master has tried to write or read partially a variable composed by more register (e.g., only one word of a floating variable).

The individual bits in Table 3-3 have the following meaning:

Bit 7: Diag.Master\_Lock

The DP-Slave has been parameterized from another master. This bit is set by the DP-Master (class 1), if the address in octet 4 is different from 255 and different from the own address. The DP-Slave sets this bit to zero.

Bit 6: Diag.Prm\_Fault

This bit is set by the DP-Slave if the last parameter frame was faulty (e.g., wrong length, wrong Ident\_Number, invalid parameters).

Bit 5: Diag.Invalid\_Slave\_Response

This bit is set by the DP-Master as soon as receiving a not plausible response from an addressed DP-Slave. The DP-Slave sets this bit to zero.

Bit 4: Diag.Not\_Supported

This bit is set by the DP-Slave as soon as a function is requested, which is not supported from this DP-Slave.

Bit 3: Diag.Ext\_Diag

This bit is set by the DP-Slave. It indicates a diagnostic entry exists in the slave specific diagnostic area (Ext\_Diag\_Data) if the bit is set to one. If the bit is set to zero, a status message can exist in the slave specific diagnostic area (Ext\_Diag\_Data). The meaning of this status message depends on the application and will not be fixed in this standard.

Bit 2: Diag.Cfg\_Fault

This bit is set by the DP-Slave as soon as the last received configuration data from the DP-Master are different from these which the DP-Slave has determined.

Bit 1: Diag.Station\_Not\_Ready

This bit is set by the DP-Slave if the DP-Slave is not yet ready for data transfer.

Bit 0: Diag.Station\_Non\_Existent

This bit is set by the DP-Master if the respective DP-Slave cannot be reached over the line. If this bit is set, the diagnostic bits contain the state of the last diagnostic message or the initial value. The DP-Slave sets this bit to zero.

### 3.6 Description of the Variable

The following table lists the variables accessible by the master specifically for the Micro-Tech 3X01 Integrators.

It is necessary at this point to make a distinction between register and variables.

A **register** is the basic unit of the data at which the master can access. The groups are structured in registers, they are numbered and the identification number is used by the master to identify the portion of a group to read or write. Their dimension is always one word.

A **variable** is the format for storing data in the Micro-Tech 3000 memory. Its dimension can change depending on the variable type. We can have:

<i>INTEGER variable</i>	An integer is a variable of 1 word (1 register). It contains integer value In the ranges 0 to 65535 or +32767 to -32768. The integer variables can be structured in array of integers with various dimensions.
<i>FLOAT variable</i>	A float is a variable of two words (2 registers). It contains REAL values in the single precision IEEE format (see Appendix A). The single precision format can represent values in the range $3.4 \cdot 10^{+38}$ to $1.18 \cdot 10^{-38}$

**NOTE:**

Some variables such as weight and rate are filtered before being displayed on the Micro-Tech 3000. In regards to communication, the Micro-Tech 3000 always sends the unfiltered value.

A lot of real values are displayed on the Micro-Tech 3000 with a number of decimals that depend on the selected division. In regards to communication, the Micro-Tech 3000 always sends the value with all the decimals.

For example:

Net weight	Display value : 10.2
	Sent value : 10.179982

#### 3.6.1 Legend

- register A conventional name
- type Can be:
  - RO The register can be read but cannot be written. It will be inserted only in the read groups.
  - RW The register can be read or written. It will be found either in the read or in the write groups.
  - WO The register can only be written. It will be inserted only in the red groups.
- low limit The minimum acceptable value for the variable. Lower values are considered an errors.
- high limit The maximum acceptable value for the variable. Higher values are considered an errors

- refresh t.      The time between two updates of the variables in the Micro-Tech 3000's memory.
- format          Can be: integer or float

**TABLE 3-4 VARIABLES AND THEIR CHARACTERISTICS**

Register	Type	Low Limit	High Limit	Refresh Time [mS]	Format
<b>Commands</b>					
Commands	WO	0	65535	-	Integer
Set/Reset Out #	WO	0	(*)	-	Integer
Command_low	WO	0	65535	-	Integer
Sim_Key	WO	(**)	(**)	-	Integer
<b>Dynamic values and status</b>					
Display	RO	-	-	200	Integer
Status	RO	-	-	-	Integer
Alarms	RO	-	-	100	Integer
IO_Image	RO	-	-	100	Integer
Rate	RO	-	-	200	Float
Belt_Load	RO	-	-	100	Float
Belt_Speed	RO	-	-	200	Float
Master_Total	RO	-	-	100	Float
Reset_Total	RO	-	-	100	Float
Operator_Total	RO	-	-	100	Float
Cal_Error	RO	-	-	-	Float
<b>Load out (batch)</b>					
Batch_Number	RW	0	999	100	Integer
Batch_Dev	RW	0	100.0	-	Integer
Batch_Set	RW	0	10000.0	-	Float
Batch_Preset	RW	0	10000.0	-	Float
Batch_Preact	RW	0	10000.0	-	Float
Batch_Total	RO	-	-	100	Float
<b>Sets and thresholds</b>					
Scale_Cap	RO	-	-	-	Float
Belt_Speed_Cap	RO	-	-	-	Float
Belt_Load_Cap	RO	-	-	-	Float
High_Rate_Set	RW	0	105.0 %	-	Float
Low_Rate_Set	RW	0	105.0 %	-	Float
High_Load_Set	RW	0	105.0 %	-	Float
Low_Load_Set	RW	0	105.0 %	-	Float
High_Speed_Set	RW	0	105.0 %	-	Float
Low_Speed_Set	RW	0	105.0 %	-	Float
H_Pos_Dev_#1/#2	RW	0	105.0 %	-	Float
HH_Pos_Dev_#1/#2	RW	0	105.0 %	-	Float
H_Neg_Dev_#1/#2	RW	0	105.0%	-	Float
HH_Neg_Dev_#1/#2	RW	0	105.0%	-	Float
<b>Regulation</b>					
Remote_Set_#1/#2	WO	0	20000	-	Float
Actual_Set_#1/#2	RO	-	-	200	Float
Control_Dev_#1/#2	RO	-	-	200	Float
Perc_Ing_#1/#2	WO	0	100.0%	-	Float

**Profibus-DP Model 3105/3205**

- (\*) Maximum limit is the number of digital inputs. It depends on the hardware configuration of the Micro-Tech 3000.
- (\*\*) All the values are accepted but only a specific set of codes are interpreted as keys. See description of the variable.

Registers in the table are explained below and are sorted in alphabetical order.

**Actual\_Set\_#1/#2**

The actual regulation set-point the instrument is using for regulation loop #1 and #2.

**Alarms**

In the alarms register, each bit represents the status of an alarm. If the alarm is active, the relevant bit will contain '1', otherwise it will contain '0'.

**Alarms 1**

15	14	13	12	11	10	09	08	07	06	05	04	03	02	01	00
A1.15 CLOCK FAIL								A1.07 LOW RATE							
A1.14 CELL FAIL								A1.06 HIGH SPEED							
A1.13 RAM FAIL								A1.05 LOW SPEED							
A1.12 ROM FAIL								A1.04 WARM START							
A1.11 SPEED SENSOR ERROR								A1.03 COLD START							
A1.10 HIGH LOAD								A1.02 PWD DURING CALIB							
A1.09 LOW ROAD								A1.01 CAL TIME ELAPSED							
A1.08 HIGH RATE								A1.00 EXTERNAL ALARM 1							

**Alarms 2**

15	14	13	12	11	10	09	08	07	06	05	04	03	02	01	00
A2.15 EXTERNAL ALARM 2								A2.07							
A2.14 EXTERNAL ALARM 3								A2.06							
A2.13 OVERFLOW TOTALIZER								A2.05							
A2.12 AZT OVER LIMIT								A2.04 BCD OVERFLOW							
A2.11 BATCH DEVIATION								A2.03 MATHEMATIC ERROR							
A2.10 HW CNF CHANGE SLOT 1								A2.02 PRINTER ERROR							
A2.09 HW CNF CHANGE SLOT 2								A2.01 COMMUNICAT. ERROR							
A2.08 HW CNF CHANGE SLOT 3								A2.00 RIO COMM ERROR							

**Alarms 3**

15	NU	NU	NU	NU	NU	NU	08	07	06	NU	NU	NU	NU	NU	NU
A3.15 PROFIB COMM ERROR								A3.07 H-HIGH POS DEV #1							
A3.14 DIGIT.COMM ERROR (*)								A3.06 HIGH NEG DEV #1							
A3.13 DIGIT.FAULT (*)								A3.05 H-HIGH NEG DEV #1							
A3.12 DIGIT POWER FAIL (*)								A3.04 HIGH POS DEV #2							
								A3.03 H-HIGH POS DEV #2							
								A3.02 HIGH NEG DEV #2							
A3.08 HIGH POS DEV #1								A3.01 H-HIGH NEG DEV #2							

(\*) Only for the Micro-Tech 3305(\*)

Alarms 4

NU	NU	NU	NU	NU	NU	NU	NU	NU	NU	NU	NU	NU	NU	NU	NU
----	----	----	----	----	----	----	----	----	----	----	----	----	----	----	----

Alarms 5

NU	NU	NU	NU	NU	NU	NU	NU	NU	NU	NU	NU	NU	NU	NU	NU
----	----	----	----	----	----	----	----	----	----	----	----	----	----	----	----

**Batch\_Dev**

The maximum acceptable deviation from the batch set point. Usually entered by the operator.

**Batch\_Number**

The number of the currently running load out or the number of the last finished one. The Micro-Tech 3000 will automatically increment the batch number when a new batch is started.

**Batch\_Preset**

The preset point for the current or the next load out. Defines when the rate will be lowered to increase batch accuracy.

**Batch\_Preact**

The set point of the preact for the current or the next load out. Entered or downloaded by the operator (if in MANUAL mode) or calculated by the Micro-Tech 3000. Defines when the load out has to stop to compensate the queue of material from the loading point to the scale.

**Batch\_Preset\_Sp**

It defines the slow rate factor in per cent of the actual regulation set point when batch preset is reached.

**Batch\_Set**

The set point for the current or the next load out. Usually entered or downloaded by the operator. For reading operations, the Batch\_set value is updated only when a batch is started.

**Batch\_Total**

The current contents of the load out totalizer. Usually read at end of batch to check the result of the load out. This register is automatically cleared when a new batch is started.

**Belt\_Load**

The instantaneous belt load in engineering units.

**Belt\_Load\_Cap**

The maximum belt load of the instrument. This value is not defined in the Micro-Tech 3000 setup, but it is internally computed by the Micro-Tech 3000. It is the reference value for the high and low belt load set points expressed in percent. It can be read only.

**Belt\_Speed**

The instantaneous belt speed in engineering units.

**Belt\_Speed\_Cap**

The maximum speed of the conveyor belt. It is the reference value for the high and low speed set points expressed in percent. It can be read only.

**Cal\_Error**

It is the error in percent resulting from a remote calibration. The master can evaluate it before accepting the result of a remote autozero or autospan.

**Commands\_high**

Each bit of the commands register is specified as follows. In order to give a command, the Host must set the relevant bit to 1 and write (send) the register to the Micro-Tech 3000. The action will be performed if the write message is accepted.

Commands

15	14	13	12	11	10	09	08	NU	NU	NU	NU	NU	02	01	00
----	----	----	----	----	----	----	----	----	----	----	----	----	----	----	----

- C1.15 AUTOSPAN RCAL
- C1.14 AUTOSPAN WTS
- C1.13 AUTOSPAN CHAINS
- C1.12 AUTOZERO
- C1.11 CONFIRM ZERO/SPAN
- C1.10 ABORT BATCH
- C1.09 STOP BATCH
- C1.08 START BATCH
- C1.02 CLEAR OPERATOR TOTAL
- C1.01 CLEAR RESET TOTAL
- C1.00 RESET ALARMS

**3.6.2 Calibration Commands**

It is possible to start a calibration function from a remote location. At the end of the calibration (calibration flag in status register should be tested to determine when cal function ends), it is possible to verify the calibration error ('cal\_error' register) and eventually accept the new zero or span.

**Autospan RCAL**

Start the autospan function with RCAL method. The RCAL is automatically connected by the Micro-Tech 3000 at the beginning of the function and disconnected at its end. Autospan RCAL has a built in delay of 0.5 seconds after START is pressed. In case a RCAL remote calibration is aborted, the calibration flags will turn of after this delay.

**Autospan WTS**

Start the autospan function with WTS method. An output of the Micro-Tech 3000 can be programmed to automatically load the test weights. This adds a 10 second delay at the beginning and at the end of the calibration function. In case a WTS remote calibration is aborted, the calibration flags will turn of after this time.

**Autozero**

Start the autozero function.

**Confirm zero/span**

At the end of the calibration function, this command tells the Micro-Tech 3000 to save the new zero or span. If this command is sent during a remote calibration, it aborts the running function.

**3.6.3 Batch Commands**

The batch can be controlled by serial.

**Stand by Batch**

Temporarily stops a Load Out (batch) sequence. Batch can resume if a Start command is sent later.

**Stop Batch**

Stop a Load Out (batch) sequence.

**Start Batch**

Start a Load Out (batch) sequence.

**3.6.4 Reset Commands**

When the Micro-Tech 3000 receives a 'Clear Reset Total' or a 'Reset alarm' command, it executes the command for all the scales.

**Clear Operator Total** Clears the operator total register.

**Clear Reset Total** Clears the reset total register.

**Reset Alarms** Resets any pending alarm.

**Commands\_Low**

Each bit of the command register is specified as follows. In order to give a command, the Host must set the relevant bit to 1 and write (send) the register to the Micro-Tech 3000. The action will be performed if the write message is accepted.

Commands

15	14	13	12	11	10	09	08	07	06	05	04	03	02	01	00
----	----	----	----	----	----	----	----	----	----	----	----	----	----	----	----

- C1.15 NOT USED
- C1.14 NOT USED
- C1.13 Force output custom 7 off
- C1.12 Force output custom 7 on
- C1.11 Force output custom 6 off
- C1.10 Force output custom 6 on
- C1.09 Force output custom 5 off
- C1.08 Force output custom 5 on
- C1.07 Force output custom 4 off
- C1.06 Force output custom 4 on
- C1.05 Force output custom 3 off
- C1.04 Force output custom 3 on
- C1.03 Force output custom 2 off
- C1.02 Force output custom 2 on
- C1.01 Force output custom 1 off
- C1.00 Force output custom 1 on

In order to give a command, the Host must set the relevant bit to 1 and write (send) the register to the Micro-Tech 3000. The action will be performed if the write message is accepted.

**Control\_Dev\_#1/#2** Actual control deviation in per cent for regulation loop #1 and #2.

**Display** The ASCII image of the Micro-Tech 3000 display.

**H\_Neg\_Dev\_#1/#2** Set point for High negative deviation alarm for regulation loop #1 and #2.

**H\_Pos\_Dev\_#1/#2** Set point for High positive deviation alarm for regulation loop #1 and #2.

**HH\_Neg\_Dev\_#1/#2** Set point for High-High negative deviation alarm for regulation loop #1 and #2.

**HH\_Pos\_Dev\_#1/#2** Set point for High-High positive deviation alarm for regulation loop #1 and #2.

**High\_Load\_Set** The set point for high weight alarm is percent of the Belt\_Load\_Cap value.

**High\_Rate\_Set** The set point for high rate alarm is percent of the Scale\_Cap value.

**High\_Speed\_Set** The set point for high speed in percent of the Belt\_Speed\_Cap value.

**IO\_Image** The Micro-Tech 3000 has physical inputs and outputs to which logical input and output functions are associated. As far as communication is concerned, only the status of physical inputs and outputs are transferred.

IO\_image 1 – mother board inputs

NU	NU	NU	NU	11	10	09	08	NU	NU	NU	NU	03	02	01	00
----	----	----	----	----	----	----	----	----	----	----	----	----	----	----	----

IO1.11	in 4 – mother board	IO1.03	in 4 – digitizer (*)
IO1.10	in 3 – mother board	IO1.02	in 3 – digitizer (*)
IO1.09	in 2 – mother board	IO1.01	in 2 – digitizer (*)
IO1.08	in 1 – mother board	IO1.00	in 1 – digitizer (*)

(\*) Only for the Micro-Tech 3301

IO\_image 2 – 4in/16out boards inputs

15	14	13	12	11	10	09	08	07	06	05	04	03	02	01	00
----	----	----	----	----	----	----	----	----	----	----	----	----	----	----	----

IO2.15	in 4 board 4i/16o #1	IO2.07	in 4 board 4i/16o #3
IO2.14	in 3 board 4i/16o #1	IO2.06	in 3 board 4i/16o #3
IO2.13	in 2 board 4i/16o #1	IO2.05	in 2 board 4i/16o #3
IO2.12	in 1 board 4i/16o #1	IO2.04	in 1 board 4i/16o #3
IO2.11	in 4 board 4i/16o #2	IO2.03	in 4 board 4i/16o #4
IO2.10	in 3 board 4i/16o #2	IO2.02	in 3 board 4i/16o #4
IO2.09	in 2 board 4i/16o #2	IO2.01	in 2 board 4i/16o #4
IO2.08	in 1 board 4i/16o #2	IO2.00	in 2 board 4i/16o #4

IO\_image 3 – 16in/4out boards #1 inputs

15	14	13	12	11	10	09	08	07	06	05	04	03	02	01	00
----	----	----	----	----	----	----	----	----	----	----	----	----	----	----	----

IO\_image 4 – 16in/4out boards #2 inputs

15	14	13	12	11	10	09	08	07	06	05	04	03	02	01	00
----	----	----	----	----	----	----	----	----	----	----	----	----	----	----	----

IO\_image 5 – 16in/4out boards #3 inputs

15	14	13	12	11	10	09	08	07	06	05	04	03	02	01	00
----	----	----	----	----	----	----	----	----	----	----	----	----	----	----	----

IO\_image 6 – 16in/4out boards #4 inputs

15	14	13	12	11	10	09	08	07	06	05	04	03	02	01	00
----	----	----	----	----	----	----	----	----	----	----	----	----	----	----	----

IOx.15	in 8 board 16i/4o # x	IOx.07	in 16 board 16i/4o # x
IOx.14	in 7 board 16i/4o # x	IOx.06	in 15 board 16i/4o # x
IOx.13	in 6 board 16i/4o # x	IOx.05	in 14 board 16i/4o # x
IOx.12	in 5 board 16i/4o # x	IOx.04	in 13 board 16i/4o # x
IOx.11	in 4 board 16i/4o # x	IOx.03	in 12 board 16i/4o # x
IOx.10	in 3 board 16i/4o # x	IOx.02	in 11 board 16i/4o # x
IOx.09	in 2 board 16i/4o # x	IOx.01	in 10 board 16i/4o # x
IOx.08	in 1 board 16i/4o # x	IOx.00	in 09 board 16i/4o # x

IO\_image 7 – mother board outputs

NU	NU	NU	NU	11	10	09	08	NU	NU	NU	NU	03	02	01	00
----	----	----	----	----	----	----	----	----	----	----	----	----	----	----	----

IO7.10	out 3 – mother board	IO7.03	out 4 – digitizer (*)
IO7.09	out 2 – mother board	IO7.02	out 3 – digitizer (*)
IO7.08	out 1 – mother board	IO7.01	out 2 – digitizer (*)
		IO7.00	out 1 – digitizer (*)

(\*) Only for the Micro-Tech 3301

IO\_image 8 – 4out/16in boards outputs

15	14	13	12	11	10	09	08	07	06	05	04	03	02	01	00
----	----	----	----	----	----	----	----	----	----	----	----	----	----	----	----

IO8.15	out 4 board 4o/16i #1	IO8.07	out 4 board 4o/16i #3
IO8.14	out 3 board 4o/16i #1	IO8.06	out 3 board 4o/16i #3
IO8.13	out 2 board 4o/16i #1	IO8.05	out 2 board 4o/16i #3
IO8.12	out 1 board 4o/16i #1	IO8.04	out 1 board 4o/16i #3
IO8.11	out 4 board 4o/16i #2	IO8.03	out 4 board 4o/16i #4
IO8.10	out 3 board 4o/16i #2	IO8.02	out 3 board 4o/16i #4
IO8.09	out 2 board 4o/16i #2	IO8.01	out 2 board 4o/16i #4
IO8.08	out 1 board 4o/16i #2	IO8.00	out 1 board 4o/16i #4

**Profibus-DP Model 3105/3205**

IO\_image 9 – 16out/4in boards #1 outputs

15	14	13	12	11	10	09	08	07	06	05	04	03	02	01	00
----	----	----	----	----	----	----	----	----	----	----	----	----	----	----	----

IO\_image 10 – 16out/4in boards #2 outputs

15	14	13	12	11	10	09	08	07	06	05	04	03	02	01	00
----	----	----	----	----	----	----	----	----	----	----	----	----	----	----	----

IO\_image 11 – 16out/4in boards #3 outputs

15	14	13	12	11	10	09	08	07	06	05	04	03	02	01	00
----	----	----	----	----	----	----	----	----	----	----	----	----	----	----	----

IO\_image 12 – 16out/4in boards #4 outputs

15	14	13	12	11	10	09	08	07	06	05	04	03	02	01	00
----	----	----	----	----	----	----	----	----	----	----	----	----	----	----	----

- |        |                         |        |                         |
|--------|-------------------------|--------|-------------------------|
| IOx.15 | out 08 board 16o/4i # x | IOx.07 | out 16 board 16o/4i # x |
| IOx.14 | out 07 board 16o/4i # x | IOx.06 | out 15 board 16o/4i # x |
| IOx.13 | out 06 board 16o/4i # x | IOx.05 | out 14 board 16o/4i # x |
| IOx.12 | out 05 board 16o/4i # x | IOx.04 | out 13 board 16o/4i # x |
| IOx.11 | out 04 board 16o/4i # x | IOx.03 | out 12 board 16o/4i # x |
| IOx.10 | out 03 board 16o/4i # x | IOx.02 | out 11 board 16o/4i # x |
| IOx.09 | out 02 board 16o/4i # x | IOx.01 | out 10 board 16o/4i # x |
| IOx.08 | out 01 board 16o/4i # x | IOx.00 | out 09 board 16o/4i # x |

- Low\_Load\_Set** The set point for low weight alarm in percent of the Belt\_Load\_Cap value.
- Low\_Rate\_Set** The set point for low rate alarm in percent of the Scale\_Cap value.
- Low\_Speed\_Set** The set point for low speed alarm in percent of the Belt\_Speed\_Cap value.
- Master\_Total** The current value of the master totalizer.
- Operator\_Total** The current value of the operator totalizer.
- Perc\_Ing\_#1/#2** It defines the ratio between the remote regulation set-point and the set-point the instrument may use for regulation loop #1 and #2
- Rate** The instantaneous rate in engineering units as currently displayed on the RUN screen.
- Remote\_Set\_#1/#2** The remote regulation set point for regulation loop #1 and #2. The instrument will use this set point when in remote.
- Reset\_Total** The current value of the reset totalizer of the Micro-Tech 3000. Reset total can be zeroed by setting a bit in the commands register.

**Scale\_Cap** The maximum flow rate of the scale. Entered by the operator in the Micro-Tech 3000 setup. It is the reference value for the high and low rate set points expressed in percent . It can only be read.

**Set/Rese\_Out#** It is a variable that allows the master to directly handle the spare digital outputs of the Micro-Tech 3000. There are 5 variables in the write group so the master has the possibility to set or reset 5 maximum outputs simultaneously.

To set or reset an output, it is only necessary to transmit the number of the physical output with the most significant bit set to 0 to reset and 1 to set. If the content is 0, the command is ignored. The Micro-Tech 3000 does not control the output the master is setting/resetting if it is a spare or not.If the master tries to change the state of a not-spare output, a conflict could happen.

**Sim\_Key** The master has the possibility to send a key code to the Micro-Tech 3000. Interpreted key code are:

**TABLE 3-5 KEY CODES**

Key	Key Code	Key	Key Code
UP ARROW	0048 H	EIGHT	0038 H
DOWN ARROW	0050 H	NINE	0039 H
DEC. POINT	002E H	MENU	004D H
CLEAR	0053 H	RUN	0052 H
ZERO	0030 H	F1	003F H
ONE	0031 H	F2	0040 H
TWO	0032 H	F3	0041 H
THREE	0033 H	AUTO/MAN	003C H
FOUR	0034 H	LOC/REM	003B H
FIVE	0035 H	START	003D H
SIX	0036 H	STOP	003E H
SEVEN	0037 H		

**Status** The actual status of the Micro-Tech 3000 is resumed in four words, each bit has its own meanings. When the bits is 1, the associated status is true.

Status 1 – Generals

15	14	13	NU	NU	NU	NU	08	07	06	05	04	03	02	NU	NU
----	----	----	----	----	----	----	----	----	----	----	----	----	----	----	----

- |       |                      |       |            |
|-------|----------------------|-------|------------|
| S1.15 | Cumulative shut down | S1.07 | High rate  |
| S1.14 | Cumulative Alarms    | S1.06 | Low rate   |
| S1.13 | Calibration running  | S1.05 | High load  |
| S1.12 | Remote               | S1.04 | Low load   |
| S1.11 | Auto                 | S1.03 | High speed |
| S1.08 | Ready                | S1.02 | Low speed  |

Status 2 – Control deviation & Batch

15	14	13	12	11	10	09	08	NU	NU	NU	NU	03	02	01	00
----	----	----	----	----	----	----	----	----	----	----	----	----	----	----	----

- |       |                   |       |                 |
|-------|-------------------|-------|-----------------|
| S1.15 | High pos dev #1   | S2.03 | Batch Suspended |
| S2.14 | H High pos dev #1 | S2.02 | Batch Phase     |
| S2.13 | High neg dev #1   | S2.01 | Batch Phase     |
| S2.12 | H High neg dev #1 | S2.00 | Batch Phase     |
| S1.11 | High pos dev #2   |       |                 |
| S1.10 | H High pos dev #2 |       |                 |
| S1.09 | High neg dev #2   |       |                 |
| S1.07 | H High neg dev #2 |       |                 |

Batch phase

Only applicable if Load Out option installed :

Bits	3	2	1	0	
	x	0	0	0	Batch not running
	x	0	0	1	Not used
	x	0	1	0	Batch running at high rate
	x	0	1	1	Batch running at low rate
	x	1	0	0	Waiting start delay time
	x	1	0	1	Waiting coasting time
	1	x	x	x	Batch suspended

Status 3 – For further use

NU	NU	NU	NU	NU	NU	NU	NU	NU	NU	NU	NU	NU	NU	NU	NU
----	----	----	----	----	----	----	----	----	----	----	----	----	----	----	----

Status 4 – For further use

NU	NU	NU	NU	NU	NU	NU	NU	NU	NU	NU	NU	NU	NU	NU	NU
----	----	----	----	----	----	----	----	----	----	----	----	----	----	----	----

## 3.7 Read Group Composition

### 3.7.1 Read Group 0 – Dynamic Variables and Status

Read Group 0 is the default group the Micro-Tech 3101 sends the master for a read request if the master does not change request (Table 3-6).

It contains dynamic values (rate, weight) and information about the status of the Micro-Tech 3000.

**TABLE 3-6 READ GROUP 0 [VAT1]**

elem. #	register	type	Offset (words)	Note
1	Staus (1)	integer	0	
2	Staus (2)	integer	1	
3	Staus (3)	integer	2	
4	Staus (4)	integer	3	
5	Alarms (1)	integer	4	
6	Alarms (2)	integer	5	
7	Alarms (3)	integer	6	
8	Alarms (4)	integer	7	
9	Alarms (5)	integer	8	
10	IO_Image (1)	integer	9	
11	IO_Image (2)	integer	10	
12	IO_Image (3)	integer	11	
13	IO_Image (4)	integer	12	
14	IO_Image (5)	integer	13	
15	IO_Image (6)	integer	14	
16	IO_Image (7)	integer	15	
17	IO_Image (8)	integer	16	
18	IO_Image (9)	integer	17	
19	IO_Image (10)	integer	18	
20	IO_Image (11)	integer	19	
21	IO_Image (12)	integer	20	
22	Rate	float	21	

23	Belt_Load	float	23	
24	Belt_Speed	float	25	
25	Master_Total	float	27	
26	Reset_Total	float	29	
27	Operator_Total	float	31	
28	Actual_Set_#1	float	33	
29	Control_Dev_#1	float	35	
30	Actual_Set_#2	float	37	
31	Control_Dev_#2	float	39	
32	Cal_Error	float	41	

### 3.7.2 Read Group 1 – Load Out

It contains data regarding the load out function (Table 3-7).

**TABLE 3-7 READ GROUP 1 [VAT2]**

elem. #	register	type	Offset (words)	Note
1	Batch_Number	integer	0	
2	Batch_Dev	integer	1	
3	Batch_Total	float	2	
4	Batch_Set	float	4	
5	Batch_Preset	float	6	
6	Batch_Preset_Sp	float	8	
7	Batch_Preact	float	10	

### 3.7.3 Read Group 2 – Sets and Thresholds

It contains the definition of the thresholds and sets the reference value (table 3-8).

**TABLE 3-8 READ GROUP 2 [VAT3]**

elem. #	register	type	Offset (words)	Note
1	Scale_Cap	float	0	
2	Belt_Load_Cap	float	2	
3	Belt_Speed_Cap	float	4	
4	High_Rate_Set	float	6	

5	Low_Rate_Set	float	8	
6	High_Load_Set	float	10	
7	Low_Load_Set	float	12	
8	High_Speed_Set	float	14	
9	Low_Speed_Set	float	16	
10	High_Pos_Dev_#1	float	18	
11	H_High_Pos_Dev_#1	float	20	
12	High_Neg_Dev_#1	float	22	
13	HHigh_Neg_Dev_#1	float	24	
14	High_Pos_Dev_#2	float	26	
15	H_High_Pos_Dev_#2	float	28	
16	High_Neg_Dev_#2	float	30	
17	HHigh_Neg_Dev_#2	float	32	

### 3.7.4 Read Group 3 – Display

It contains the image of the Micro-Tech 3000 display (Table 3-9).

**TABLE 3-9 READ GROUP 3 [VAT4]**

elem. #	register	type	Offset (words)	Note
1	Display (1)	integer	0	
2	Display (2)	integer	1	
3	Display (3)	integer	2	
4	Display (4)	integer	3	
5	Display (5)	integer	4	
6	Display (6)	integer	5	
7	Display (7)	integer	6	
8	Display (8)	integer	7	
9	Display (9)	integer	8	
10	Display (10)	integer	9	
11	Display (11)	integer	10	
12	Display (12)	integer	11	

**Profibus-DP Model 3105/3205**

13	Display (13)	integer	12	
14	Display (14)	integer	13	
15	Display (15)	integer	14	
16	Display (16)	integer	15	
17	Display (17)	integer	16	
18	Display (18)	integer	17	
19	Display (19)	integer	18	
20	Display (20)	integer	19	
21	Display (21)	integer	20	
22	Display (22)	integer	21	
23	Display (23)	integer	22	
24	Display (24)	integer	23	
25	Display (25)	integer	24	
26	Display (26)	integer	25	
27	Display (27)	integer	26	
28	Display (28)	integer	27	
29	Display (29)	integer	28	
30	Display (30)	integer	29	
31	Display (31)	integer	30	
32	Display (32)	integer	31	
33	Display (33)	integer	32	
34	Display (34)	integer	33	
35	Display (35)	integer	34	
36	Display (36)	integer	35	
37	Display (37)	integer	36	
38	Display (38)	integer	37	
39	Display (39)	integer	38	
40	Display (40)	integer	39	

### 3.8 Write Group Composition

#### 3.8.1 Write Group 100 - Commands

Commands can be sent to set/reset outputs (Table 3-10).

**TABLE 3-10 WRITE GROUP 100 [VAT5]**

elem. #	register	type	Offset (words)	Note
1	Commands high	integer	0	
2	Set/Res Out #	integer	1	
3	Set/Res Out #	integer	2	
4	Set/Res Out #	integer	3	
5	Set/Res Out #	integer	4	
6	Set/Res Out #	integer	5	
7	Sim_Key	integer	6	
8	Commands low	integer	7	

#### 3.8.2 Write Group 101 – Load Out

**TABLE 3-11 WRITE GROUP 101 [VAT6]**

elem. #	register	type	Offset (words)	Note
1	Batch_Number	integer	0	
2	Batch_Dev	integer	1	
3	Batch_Set	float	2	
4	Batch_Preset	float	4	
5	Batch_Preset_Sp	float	6	
6	Batch_Preact	float	8	
7	Perc Ingredient 1	float	10	
8	Perc Ingredient 2	float	12	

### 3.8.3 Write Group 102 – Set and Thresholds

TABLE 3-12 WRITE GROUP 102 [VAT7]

elem. #	register	type	Offset (words)	Note
1	Not Used	integer	0	
2	Not Used	integer	1	
3	Remote_Set_#1	float	2	
4	Remote_Set_#2	float	4	
5	High_Rate_Set	float	6	
6	Low_Rate_Set	float	8	
7	High_Load_Set	float	10	
8	Low_Load_Set	float	12	
9	High_Speed_Set	float	14	
10	Low_Speed_Set	float	16	
11	High_Pos_Dev_#1	float	18	
12	H_High_Pos_Dev_#1	float	20	
13	High_Neg_Dev_#1	float	22	
14	H_High_Neg_Dev_#1	float	24	
15	High_Pos_Dev_#2	float	26	
16	H_High_Pos_Dev_#2	float	28	
17	High_Neg_Dev_#2	float	30	
18	H_High_Neg_Dev_#2	float	32	

## Appendix A

# Floating Point Notation

Micro-Tech 3000 stores floating point data types using the IEEE single precision format. The format contains a sign bit, an exponent field and a fraction field or mantissa.

### The represent value

The value of the number being represented is equal to the exponent multiplied by the fractional part with the sign specified by the bit sign field :

$$(-1)^{\text{sign}} * (1.0 + \text{fraction}) * s^{(\text{exp} - \text{bias})}$$

For detailed information, refer to the *ANSI IEEE Standard for Binary Floating Point Arithmetic*.

### Sign Bit

The sign of the number being represented is stored in the sign bit. If the number is positive, the sign bit contains the value 0. If it is negative, it contains the value 1. The sign bit is stored in the most significant bit of a floating point value.

### Exponent Field

Using an exponent increases the range of representable numbers. The exponent field of the number contains a 'biased' form of the exponent. A bias is subtracted from the exponent field, letting the actual exponent represent both positive and negative exponents. The value of this bias is hexadecimal 7F; therefore, the effective exponent (Rexp) of the number can be obtained as:

$$\text{Rexp} = \text{Exp} - 7F$$

**Note:** If both the exponent field and the fraction field are equal to zero, the number being represent is zero.

### Fraction field (Mantissa)

IEEE floating point format stores the fractional part of a number in a "normalized" form. It assumes that all nonzero numbers are of the following form:

$$1.\text{xxxxxxxx (binary)}$$

The character x represent either 0 or 1 (binary).

Since floating point numbers begin with 1, the 1 becomes the implicit normalized bit. It is the most significant bit of the fraction and is not stored in memory. The binary point is located immediately to the right of the normalized bit. All bits after the binary point represent values less the 1 (binary).

Example:

The number 1.625 (dec) can be represented as:

$$1.101 \text{ (bin)}$$

This number can be represented in decimal as:

$$2^0 + 2^{-1} + 2^{-3} \text{ (dec) Or } 1 + 0.5 + 0.25$$



$$\text{Value} = 2^2(\text{imp}) + 2^0 + 2^{-1} = 5.5 \text{ (negative)}$$



## Appendix B The GSD File

PROFIBUS devices have different performances characteristics. Features differ in regards to available functionality or possible bus parameters, such as baud rate and time monitoring. These parameters vary individually for each device type and vendor. For this reason, the PROFIBUS Organization has standardized a database file, it contains all the characteristics of the PROFIBUS device and must be delivered by the vendor together with the device. This file has a name that depends by the vendor and an extension that is normally GSD, but can be different depending by the country of origin of the device. The third letter of the extension defines the country:

- D - Default, is valid for each country
- I - Italian
- G - German
- E - English
- F - French
- P - Portuguese
- S - Spanish

Refers to the manual of the device you are using as Master of your PROFIBUS network to get information about how to use the GSD file.

These are the main PROFIBUS characteristics of the Thermo Ramsey Micro-Tech 3105.

Vendor	Thermo Ramsey
Model	Micro-Tech 3105
Ident number	0x2101
Protocol	Standard DP
Baud rate supported	from 9.6 kb to 12 Mb
Freeze Mode supp	NO
Sync Mode supp	NO
Auto Baud supp	YES
Set Slave Add_supp	NO
Station Type	Compact
Prm Data Length	7
Diag Data Length	8
Config Data Length	9
Input Data Length (write buffer)	5-48 word, coherency over word
Output Data Length (read buffer)	5-48 word, coherency over word

### To change I/O data length

The Micro-Tech 3000 gives the possibility to define the write and read buffer dimensions. Default values are 48 words for both. If the operator changes them, he should also modify the GSD file so that he configuration in the Micro-Tech 3000 setup and in the file corresponds.

To make it is easy, the GSD file should be edited with a normal text editor and the value at the directive >module = at the bottom of the file should be changed. It normally appears as follows:

```
Module = "MT3000" 0xC0,0x6F,0x6F
```

### Profibus DP Model 3101/3201

The first value (0xC0) should be left unchanged, the second value specifies the dimension of the write buffer, the third of the read buffer.

The value to set should be computed as follows:

Read\_Buffer\_Dim = 63 + RBD

Write\_Buffer\_Dim = 63 + WBD

where:

RBD is the read buffer dimension defined in the Micro-Tech 3000 setup.

WBD is the write buffer dimension defined in the Micro-Tech 3000 setup.

The value should be then converted and written in hexadecimal notation.

The meaning of the default values 0x6F is:

6F hex = 111 dec = 63 + 48

48 is the default dimension of the buffers.

Instructions are also contained in the GSD file.

The following is the contents of the Thermo Ramsey Micro-Tech 3105 GSD file.

R MT2105.GSD used for Mod.3105/3205

```
#Profibus_DP
GSD_Revision          = 1
;
Vendor_Name           ="Ramesy"
Model_Name            ="MT2105"
Revision              ="Rev.A"
Ident_Number          = 0x2105
Protocol_Ident        = 0
Station_Type          = 0
FMS_supp              = 0
Hardware_Release      ="Rev.A"
Software_Release      ="39.GSD.01"
;
9.6_supp              = 1
19.2_supp             = 1
93.75_supp            = 1
187.5_supp            = 1
500_supp              = 1
1.5M_supp             = 1
3M_supp               = 1
6M_supp               = 1
12M_supp              = 1
;
MaxTcdr_9.6           = 60
MaxTcdr_19.2          = 60
MaxTcdr_93.75         = 60
MaxTcdr_187.5         = 60
MaxTcdr_500           = 100
Max Tcdr_1.5M         = 150
MaxTcdr_3M            = 250
MaxTcdr_6M            = 450
MaxTcdr_12M           = 800
;
Redundancy            = 0
Repeater_Ctrl_Sig     = 0
```

```

24V_Pins                = 0
Implementation_Type     ="ifak"
Bitmap_Device           ="dev.dib."
Bitmap_Diag             ="diag.dib"
Bitmap_SF               ="sf.dib"
;
Freeze_Mode_supp       = 0
Sync_Mode_supp         = 0
Auto_Baud_supp         = 1
Set_Slave_Add_supp     = 0
Min_Slave_Intervall    = 12
;
Modular_Station        = 0
Modul_Offset           = 1
Max_User_Prm_Data_Len  = 7
;
Fail_Safe              = 0
Slave_Family           = 5
Max_Diag_Data_Len     = 8
;
Unit_Diag_Bit(0)       ="Coherency Error"
Unit_Diag_Bit(1)       ="Limits Error"
Unit_Diag_Bit(2)       ="Register Number Error"
Unit_Diag_Bit(3)       ="Group ID Error"
;
;
;

```

Buffers dimension

Standard buffer dimensions is : 48 words read buffer (0x6F)  
 48 words write buffer (0x6F)

Dimensions can be changed by modifying the last two values in the "Module" definition below.

The value should be obtained as follows :

$$63 + WB\_WN \quad \text{or} \quad 63 + RB\_WN$$

where WB\_WN is the wished words number for the write buffer, RB\_WN is the wished words number for the read buffer.

The value should be converted in hexadecimal format. Default value hex 6F correspond to :

$$63 + 48 \quad \rightarrow \quad 111 \text{ dec} \quad \rightarrow \quad 6F \text{ hex}$$

WB\_WN and RB\_WN values must be entered also in the Micro-Tech 3000 setup in decimal format

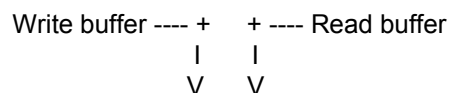

```

Module = "MT2000" 0xC0,0x6F,0x6F
1
EndModule

```