

SERIAL COMMUNICATIONS MANUAL

FOR RAMSEY

MICRO-TECH™ 2104

LOSS-IN-WEIGHT

FEEDER CONTROLLER

RAMSEY

A THERMO SENTRON COMPANY

501 90th Avenue N.W. • Minneapolis, MN 55433 • 612.783.2500

REC 3951 REV C 12/98
PART NO. 050578

REVISION HISTORY

REVISION A	OCTOBER 1996
REVISION B	SEPTEMBER 1998
REVISION C	DECEMBER 1998

COPYRIGHT 1996, 1998 BY RAMSEY TECHNOLOGY, INC.

THIS DOCUMENT IS CONFIDENTIAL AND IS THE PROPERTY OF RAMSEY TECHNOLOGY, INC. ("RAMSEY"). IT MAY NOT BE COPIED OR REPRODUCED IN ANY WAY WITHOUT THE EXPRESS WRITTEN CONSENT OF RAMSEY. THIS DOCUMENT ALSO IS AN UNPUBLISHED WORK OF RAMSEY. RAMSEY INTENDS TO AND IS MAINTAINING THE WORK AS CONFIDENTIAL INFORMATION. RAMSEY ALSO MAY SEEK TO PROTECT THIS WORK AS AN UNPUBLISHED COPYRIGHT. IN THE EVENT OF EITHER INADVERTENT OR DELIBERATE PUBLICATION, RAMSEY INTENDS TO ENFORCE ITS RIGHTS TO THIS WORK UNDER THE COPYRIGHT LAWS AS A PUBLISHED WORK. THOSE HAVING ACCESS TO THIS WORK MAY NOT COPY, USE OR DISCLOSE THE INFORMATION IN THIS WORK UNLESS EXPRESSLY AUTHORIZED BY RAMSEY.

**PLEASE READ AND OBSERVE THE FOLLOWING SAFETY
PRECAUTIONS FOUND THROUGHOUT THIS MANUAL.**

DANGER

FAILURE TO OBSERVE WILL CAUSE VERY SERIOUS PERSONAL INJURY OR DEATH.

WARNING

FAILURE TO OBSERVE COULD CAUSE SERIOUS PERSONAL INJURY.

CAUTION

FAILURE TO OBSERVE MAY CAUSE MINOR OR MODERATE PERSONAL INJURY
OR DAMAGE TO THE EQUIPMENT.

RAMSEY PRODUCTS
MICRO-TECH 2104 LOSS-IN-WEIGHT FEEDER CONTROLLER

TABLE OF CONTENTS

<u>CHAPTER</u>	<u>TITLE</u>	<u>PAGE</u>
1.0	INTRODUCTION	1-1
1.1	GENERAL	1-1
1.2	COMMUNICATION PROTOCOLS	1-2
	1.2.1 Protocol Rules	1-2
1.3	PRINTER	1-3
1.4	WARRANTY	1-4
2.0	INSTALLATION	2-1
2.1	GENERAL	2-1
2.2	COMM "A" BOARD INSTALLATION	2-1
3.0	OPERATION	3-1
3.1	GENERAL	3-1
3.2	PRINTER SCROLL	3-1
3.3	PRINT FORM	3-2
	3.3.1 Totals	3-2
	3.3.2 Batch	3-3
	3.3.3 Alarms	3-3
	3.3.4 Audit Trails	3-3
3.4	COMMUNICATION SET-UP	3-4
	3.4.1 Clock/Calendar Set-Up	3-4
	3.4.2 COMM A Scroll Set-Up	3-5
	3.4.3 Multidrop Operator Set-Up	3-7
	3.4.4 Second COMM A Board	3-8
	3.4.5 Printer Set-Up	3-10
	3.4.6 Define Printing Format	3-12
3.5	COMMUNICATION PROTOCOLS	3-18
	3.5.1 Registers Definition	3-19
	3.5.2 Type, Limits and Format of Registers	3-20

TABLE OF CONTENTS
(continued)

<u>CHAPTER</u>	<u>TITLE</u>	<u>PAGE</u>
	3.5.3 Description of Registers	3-21
3.6	PC-MASTER PROTOCOL	3-33
	3.6.1 Description	3-33
3.7	SIEMENS 3964R	3-37
	3.7.1 Write Register	3-37
	3.7.2 Read Register	3-38
3.8	MODBUS	3-40
	3.8.1 Read Registers	3-40
	3.8.2 Write Registers	3-41
	3.8.3 Write Word	3-42
3.9	ALLEN BRADLEY DF1 (PLC-5)	3-44
	3.9.1 Read Registers	3-44
	3.9.2 Write Registers	3-46
3.10	REGISTER MAPPING	3-48
4.0	MAINTENANCE	4-1
4.1	GENERAL	4-1
5.0	PARTS	5-1
5.1	GENERAL	5-1

LIST OF ILLUSTRATIONS

<u>FIGURE NO.</u>	<u>TITLE</u>	<u>PAGE</u>
2-1	COMM "A" Board	2-2
2-2	Model 2104 Mother Board	2-3
2-3	Micro-Tech 2104 Static Weight Indicator, Serial Connection RS232	2-4
2-4	Micro-Tech 2104 Static Weight Indicator, Serial Connection RS485	2-5

LIST OF TABLES

<u>TABLE NO.</u>	<u>TITLE</u>	<u>PAGE</u>
2-1	COMM A Board Jumpers	2-1

APPENDIX

<u>NO.</u>	<u>TITLE</u>
A/1	Field Wiring Drawings

CHAPTER 1.0 INTRODUCTION

1.1 GENERAL

The Micro-Tech 2104 is a bus-based microprocessor instrument that can be optionally equipped with one or two COMM "A" serial communication boards. Each COMM "A" board has one serial channel that can be configured according to the following standards.

- RS423/RS232C For point to point asynchronous bidirectional communications, maximum 50 feet (15 m). Modem capability.
- RS485/RS422 For point to point or multidrop 4 wire bidirectional communications, maximum 4000 feet (1200 m).
- Current Loop For high immunity bidirectional asynchronous communications. Passive only.

All of the above are optically isolated.

COMM "A" boards can be installed in any available mother board expansion slot. After installing the board and power has been restored, the instrument automatically detects the new board and adds the communication set-up scrolls to the Main Menu scrolls.

Two COMM "A" boards may be installed; one can be set up for printing, the other for transferring data to and from other intelligent devices such as computers and PLC's. The system cannot support two printers or two COMM lines. The Micro-Tech refers to the COMM "A" board installed in the lower numbered slot as COM 1, and the second board (if installed) as COM 2.

Each COMM "A" board contains a perpetual clock/calendar circuit with battery backup. The battery is located on the mother board and is the same battery used for system memory backup. The system automatically detects and uses the clock calendar circuit of the first board and ignores the second.

Time and date set-up screens become visible after the COMM board is installed.

1.2 COMMUNICATION PROTOCOLS

When a COMM line is set up for communication (not for a printer), the system is able to send and receive data to and from another device connected to the COMM line. The COMM option comes with the following software communication protocols already built in:

- PC-Master A Ramsey proprietary protocol, multidrop.
- Modbus An AEG proprietary protocol, multidrop. The COM option only contains a subset of the protocol as specified in this manual.
- Allen Bradley A proprietary protocol, multidrop. The COMM option only contains a subset of the protocol in the PLC-5 version of it, as specified in this manual.
- 3964R A Siemens proprietary protocol, single point.

The hardware can be configured (through jumpers on the COMM board) to one of the three standards as listed in the previous paragraph. However, only the RS485/RS422 standard allows multidrop communications, RS232C and Current Loop can only be used in point to point mode. This does not prevent the use of a protocol; it only prevents physically connecting the Micro-Tech 2104 to more than one device.

CAUTION

The communication protocols have been implemented and tested as described in this document or in other referenced documents. It is the intention of Ramsey to provide all the necessary information and help the user to connect the instrument to other compatible devices.

However, because most of the protocols are specific to other manufacturers, Ramsey declines any responsibility for any malfunction that may occur when connecting the instrument to devices of other manufacturers, unless tested and approved by Ramsey.

1.2.1 Protocol Rules

The communication protocol allows a remote intelligent device to read and eventually write information from and to the Micro-Tech 2104. For convenience, the information is organized in a set of registers as listed in this document.

During the communication activity, the Micro-Tech 2104 always acts as Slave, meaning it responds to a request from a Master device on the line, but never attempts to send messages out.

The following rules apply:

- a. The Micro-Tech 2104 responds only if the message is completely received.
- b. The Micro-Tech 2104 reads the message and looks for the address, which is contained into an address byte in the query package. The message is then processed only if the address matches the one specified in the set-up data of the Micro-Tech 2104, otherwise it is ignored.
- c. When the system receives a message, the integrity of the message is checked. An answer-back message is prepared if the message is formally correct.
- d. When a message containing a variable to be written in memory is received, the system checks the correctness of the message and, if it is correct,

immediately sends the answer-back message. This does not always mean the data is written in memory. The system first checks the register number (which must correspond to a valid address of a variable), then the minimum and maximum limits, and then the password. If data can be accepted, it is stored in memory and the success flag is set to 0 (no error); if not, it is set to 1. To know if the last variables sent have been stored, the Master checks (reads) the success flag contained in a read only register.

The following procedure applies:

- The Host sends data to the Micro-Tech 2104.
- The Host waits at least 100 ms.
- The Host reads the success flag. It should be 0.

Some data is read only, some is read write, and some is write only.

WARNING

In all cases, the maximum number of words the system can transfer is limited to 41 per time. Requests of registers in excess of 41 are considered errors and do not generate an answer.

1.3 PRINTER

When a COMM line is set up for printing, the system prints out data in different ways, depending on the set-up. Print menus become visible that allow the user to define when and in which format the data is printed.

1.4 WARRANTY

RAMSEY TECHNOLOGY, INC.

The seller agrees, represents, and warrants that the equipment delivered hereunder shall be free from defects in material and workmanship. Such warranty shall not apply to accessories, parts, or material purchased by the seller unless they are manufactured pursuant to seller's design, but shall apply to the workmanship incorporated in the installation of such items in the complete equipment. To the extent purchased parts or accessories are covered by the manufacturer's warranty, seller shall extend such warranty to buyer.

Seller's obligation under said warranty is conditioned upon the return of the defective equipment, transportation charges prepaid, to the seller's factory in Minneapolis, Minnesota, and the submission of reasonable proof to seller prior to return of the equipment that the defect is due to a matter embraced within seller's warranty hereunder. Any such defect in material and workmanship shall be presented to seller as soon as such alleged errors or defects are discovered by purchaser and seller is given opportunity to investigate and correct alleged errors or defects and in all cases, buyer must have notified seller thereof within one (1) year after delivery, or one (1) year after installation if the installation was accomplished by the seller.

Said warranty shall not apply if the equipment shall not have been operated and maintained in accordance with seller's written instructions applicable to such equipment, or if such equipment shall have been repaired or altered or modified without seller's approval; provided, however, that the foregoing limitation of warranty insofar as it relates to repairs, alterations, or modifications, shall not be applicable to routine preventive and corrective maintenance which normally occur in the operation of the equipment.

"EXCEPT FOR THOSE WARRANTIES SPECIFICALLY CONTAINED HEREIN, SELLER DISCLAIMS ANY AND ALL WARRANTIES WITH RESPECT TO THE EQUIPMENT DELIVERED HEREUNDER, INCLUDING THE IMPLIED WARRANTIES OF MERCHANTABILITY AND FITNESS FOR USE. THE SOLE LIABILITY OF SELLER ARISING OUT OF THE WARRANTY CONTAINED HEREIN SHALL BE EXCLUSIVELY LIMITED TO BREACH OF THOSE WARRANTIES. THE SOLE AND EXCLUSIVE REMEDY FOR BREACH OF THE WARRANTIES SET OUT ABOVE SHALL BE LIMITED TO THE REPAIR OR REPLACEMENT OF ANY DEFECTIVE ACCESSORY, PART OR MATERIAL WITH A SIMILAR ITEM FREE FROM DEFECT, AND THE CORRECTION OF ANY DEFECT IN WORKMANSHIP. IN NO EVENT SHALL SELLER BE LIABLE FOR ANY INCIDENTAL OR CONSEQUENTIAL DAMAGES."

FIELD SERVICE

Purchaser agrees to underwrite the cost of any labor required for replacement; including time, travel, and living expenses of Ramsey Field Service Engineer at closest factory base.

RAMSEY TECHNOLOGY, INC.
501 90th Avenue N.W.
Minneapolis, MN 55433
Phone: (612) 783-2500
Fax: (612) 783-2525

CHAPTER 2.0 INSTALLATION

2.1 GENERAL

This chapter describes the installation procedure and hardware configuration for the communications option. If the communications option was installed at the factory, it may not be necessary to continue with this chapter. Proceed to Chapter 3.0, Operation.

2.2 COMM "A" BOARD INSTALLATION

To install the COMM "A" board(s), proceed as follows:

1. Select the jumper positions on the COMM "A" board for the desired communication standard. Below is a table which summarizes the jumper positions for selection of the electrical interface. Refer to Figure 2-1 for jumper locations.

**TABLE 2-1
COMM "A" BOARD JUMPERS**

JUMPERS						
Mode	OP1	OP2	OP3	OP4	OP5	OP6
RS-232	"A"	"A"	"A"	"A"	"A"	"B"
RS-485	"B"	"A"	"B"	"B"	"A"	"B"
20 mA	"B"	"B"	"A"	"A"	"A"	"C"

[Default]

TABLE "MDP"

FOR RS-485 ONLY

OP5

"A" NORMAL

"B" MULTIDROP

TABLE "TRM"

FOR RS-485 ONLY

OP6

"A" TERMINATED

"B" NOT TERMINATED

2. Open the Micro-Tech wall mount enclosure and turn power off at the mains, or remove panel mount enclosure from the panel and remove top cover allowing access to the mother board.
3. Remove the field mating connector. Wire the connector per the supplied field wiring diagram or install field terminal board cable (wall mount only).
4. Remove the hex head mounting screw from the connector end of the COMM board.
5. Insert the COMM board in any available expansion slot on the mother board (see Figure 2-2).

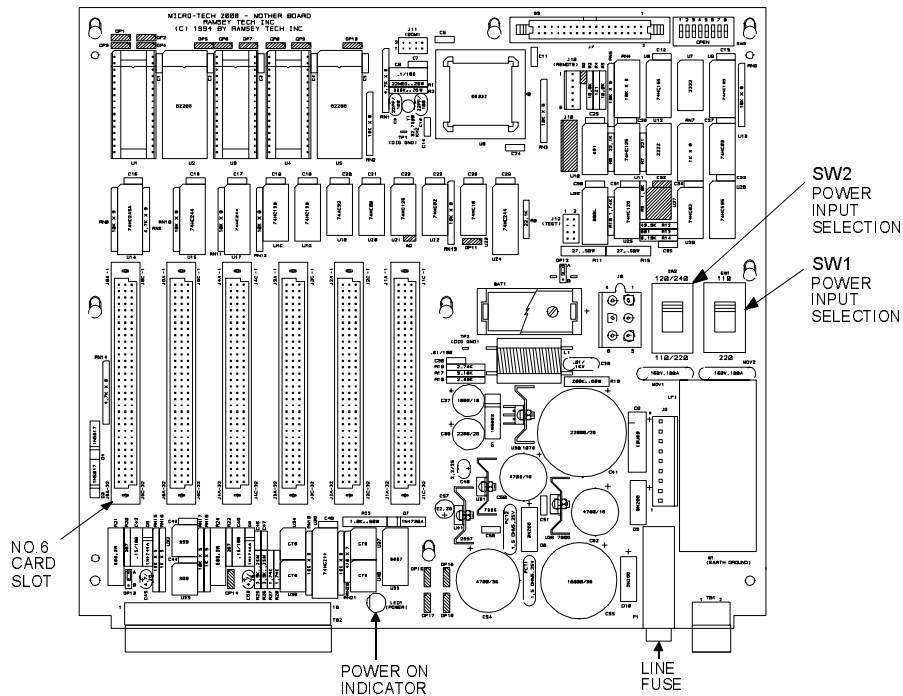

A00926

MODEL 2104 MOTHER BOARD
FIGURE 2-2

6. Insert the hex head screw through the chassis and tighten.
7. Install the wired mating connector on the COMM board connector.
8. Reinstall panel mount enclosure in the panel.
9. Turn power back on. The following screen appears when power is applied and remains on for 10 seconds.

```

-SLOT #   n   CHANGED
Acquire new
configuration ?
YES      NO

```

The screen disappears after 10 seconds if the question is not answered, and the Micro-Tech 2104 assumes the answer is NO. "HW CONFIG. CHANGED" alarm is on and cannot be reset. The above screen appears each time power is cycled if the question is not answered.

Answer YES because this is a hardware configuration change.

10. This completes the installation procedure.
11. Set-up data for the newly installed COMM board must now be entered. Proceed to Chapter 3.0, Operation.

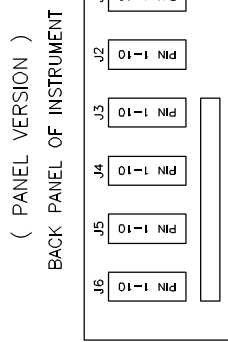
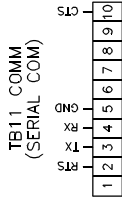
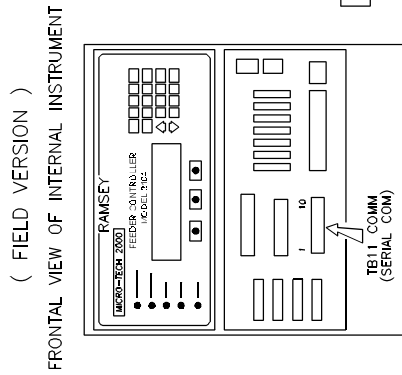

THE SERIAL COM BOARD CAN BE MOUNTED ON SLOT POSITION J1-J6. DEFAULT POSITION (J5)

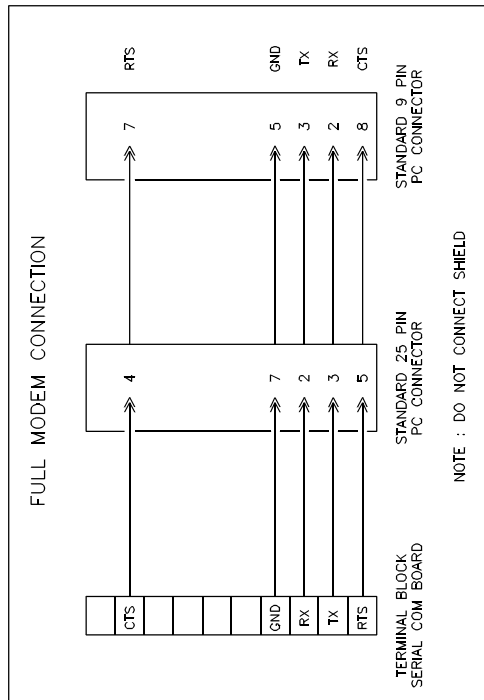
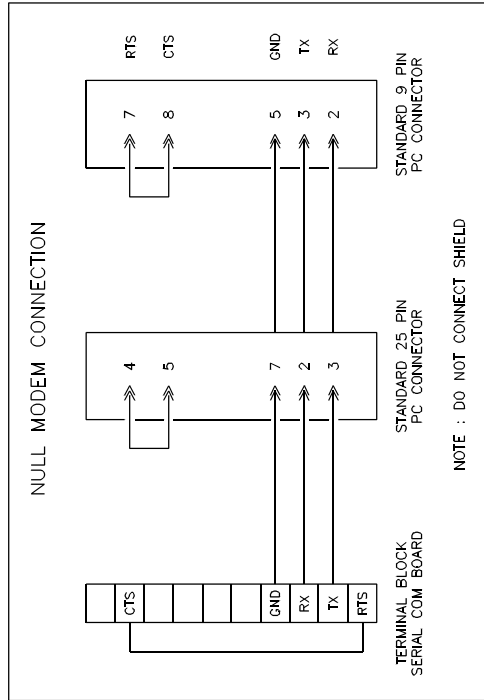
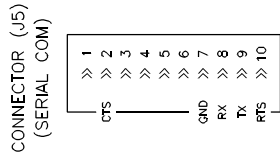

MICRO-TECH 2104 FEEDER CONTROLLER
SERIAL CONNECTION RS232
FIGURE 2-3

A01219

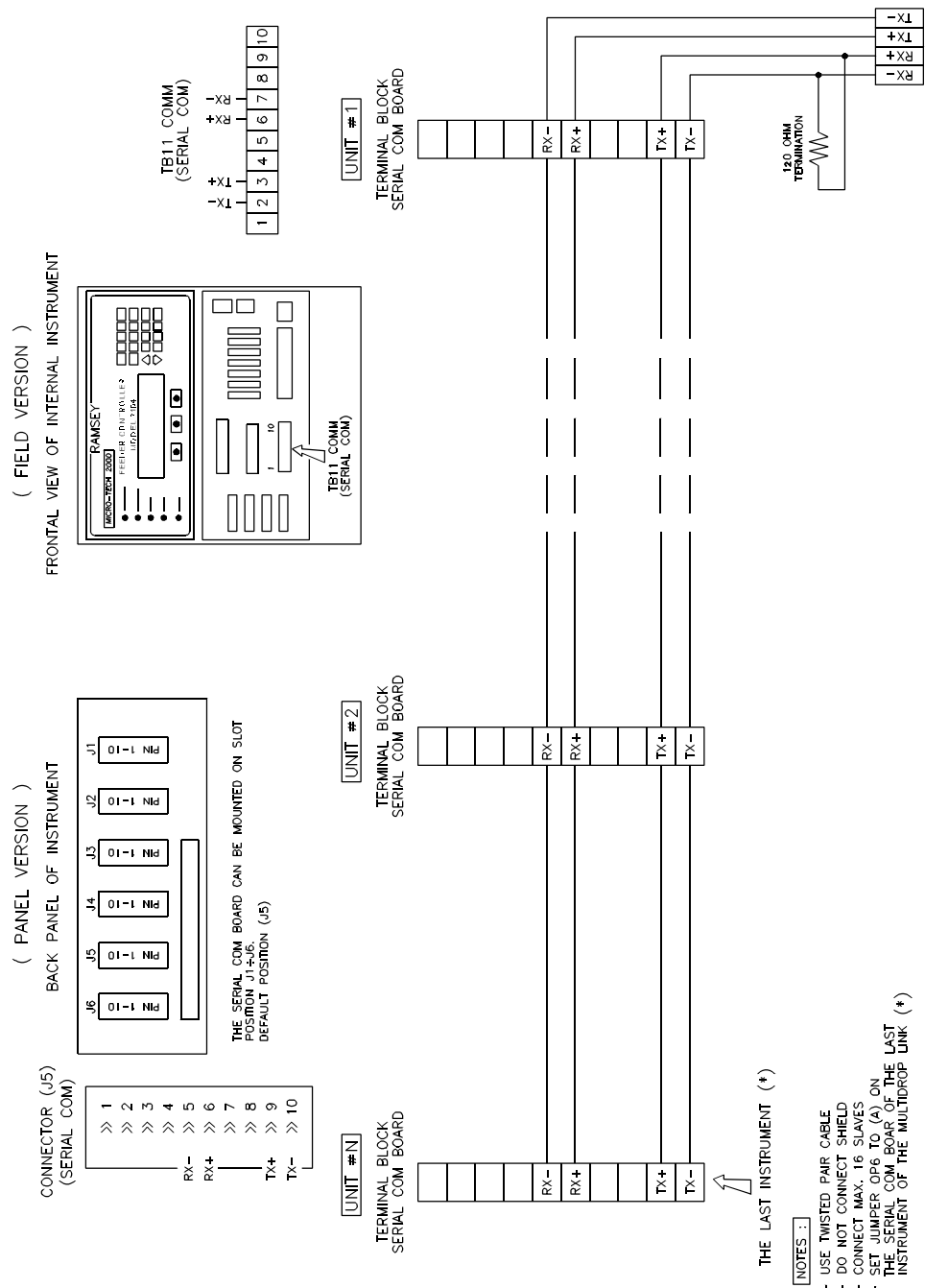

A01220

MICRO-TECH 2104 FEEDER CONTROLLER
SERIAL CONNECTION RS485
FIGURE 2-4

CHAPTER 3.0 OPERATION

3.1 GENERAL

The Micro-Tech 2104 is a menu driven machine that allows the operator easy access to all communication and printer set-up scrolls. Main Menu 3's Diagnostic Scroll contains the clock/calendar set-up screens. Main Menu 2's Display Scroll contains the clock/calendar configuration screens, and Main Menu 5 contains the communications and printer set-up scrolls.

The PRINT key enables the Micro-Tech 2104 to print the data selected in the Printer Scroll. Periodical printing and alarms print when directed by the system if enabled.

3.2 PRINTER SCROLL

The printer scroll is accessible by pressing the PRINT key in the RUN menu or, if two scales are defined, in Main Menu 1. It is a single screen menu which allows the operator to select a report and start a printing.

The following screen is displayed:

<pre>- PRINTER SCROLL - COM #1 no data (1) Start print TOTALS(2) PRINT RETURN COM(3)</pre>	Password: Not required
--	------------------------

The second line (1) gives the status of the printer:

NO DATA Indicates the printer is idle, no data are being sent to the printer.

IS RUNNING The system is sending data to the printer.

The third line (2) indicates what data is printed when the PRINT key is pressed. The Up and Down keys select between:

TOTALS Print totals (both scales if two scales are defined)

TOTALS S1 Print totals scale 1

TOTALS S2 Print totals scale 2 (only if enabled)

TRAILS If audit trails option is active, print audit trails data.

Print starts after the PRINT key is pressed.

The COM key (3) allows printer selection if more than one printer is used.

3.3 PRINT FORM

The printer can be set up to print totals, batch reports, and audit trails upon request. Batch reports and audit trails require optional hardware. In addition, totals can be printed at four predetermined intervals and enabled alarms printed at the time they occur.

3.3.1 Totals

There are two formats for printing totals; one is predefined, one is user programmable. Selection between the two formats is done via the Print Scroll in Main Menu 5.

Examples of data that can be printed:

1. TOTALS, default:

If one scale only:

TOTALS REPORT

DATE: 12-10-1998

TIME: 8:12a

MASTER TOTAL: 0.00 Tons

RESET TOTAL: 0.00 Tons

If two scales:

TOTALS REPORT

DATE: 12-10-1998

TIME: 8:12a

SCALE 1

MASTER TOTAL: 0.00 Tons

RESET TOTAL: 0.00 Tons

SCALE 2

MASTER TOTAL: 0.00 Tons

RESET TOTAL: 0.00 Tons

2. USER PROGRAMMABLE

The USER PROGRAMMABLE format includes three programmable strings. The position of each datum on the paper can be assigned by row and column, making it easy to fulfill any custom requirement.

3.3.2 Batch

If the optional Load Out board is installed, the load out data can be printed in the following format:

BATCH REPORT

DATE: 12-10-1998

TIME: 8:12a

BATCH NR: 0

SET PT: 0.00 Tons

TOTAL : 0.00 Tons

3.3.3 Alarms

The system can optionally print out each alarm (if the alarm has been turned on in the Alarms Menu) in the following format:

12-10-1998 8:14a

High rate

where "High rate" is only an example of a possible alarm condition. Date and time corresponds to when the alarm has occurred the first time.

3.3.4 Audit Trails

When Audit Trails is installed, the recorded data can be printed out in the following format:

TRAIL RECORD NR 1

DATE 12-10-1998 TIME 11:59p

VARIABLE scale cap

NEW 400.00

OLD 500.00

TRAIL RECORD NR 2

DATE 12-10-1998 TIME 11:31p

VARIABLE span

NEW 250000

OLD 300000

TRAIL RECORD NR 3

DATE 12-10-1998 TIME 11:59p

VARIABLE div (e)

NEW 0.05

OLD 0.1

Each record contains a description of the variable which has been altered, the old and the new values of the variable, and an index number.

3.4 COMMUNICATION SET-UP

This section explains the communication and printer set-up. See Section 3.5 for communication protocols detailed description.

3.4.1 Clock/Calendar Set-Up

When an optional COMM "A" board is installed, date and time become available and must be set. The battery, located on the mother board, provides backup for the perpetual calendar/clock. Time and date needs to be set only once.

1. Press the MENU key until Main Menu 3 appears. Press the soft key under the DIAGNOSTICS scroll and scroll down until -DIAGNOST SCROLL 7- appears.

The following scroll is provided to set up the date, and enter the day, month and year in sequence.

```
-DIAGNOST. SCROLL 7-  
Date:   DD-MM-YYYY  
DAY:    DD  
ENTER
```

Password: SERVICE

Default: 00-00-0000
Min: 01-01-1997
Max: 12-31-2096

Time is entered in a similar way. The **AM/PM** key is used when time is in the English mode (see Display Scroll 7 below).

```
-DIAGNOST. SCROLL 8-  
Time:   HH:MM  
HOURS: HH  
ENTER           AM/PM
```

Password: SERVICE

24 hour am/pm
Default: 00:00 01:00
Min: 00:00 01:00
Max: 23:59 12:59

2. Press the MENU key until Main Menu 2 appears. Press soft key under DISPLAY scroll and scroll down until -DISPLAY SCROLL 7- appears.

The user can define the format for displaying and printing time and date. Select the 24 hours or 12 hours format:

```
- DISPLAY SCROLL 7 -  
Time  
> 24 h<  
CHOICE ENTER
```

Password: SERVICE

If USA or English: Default: am/pm
If other language: Default: 24 h
Selections: am/pm, 24 h

Then date can be set to show month or day first, in three possible configurations:

```
- DISPLAY SCROLL 8 -  
Date  
> MM-DD-YYYY <  
CHOICE ENTER
```

Password: SERVICE

If USA: Default: MM-DD-YYYY
If other language: Default: DD-MM-YYYY
Selections: DD-MM-YYYY, MM-DD-YYYY, YYYY-MM-DD

3. When a COMM board is installed, date and time can be displayed line three (3) in the RUN screen if selected using DISPLAY SCROLL 9.

```
- DISPLAY SCROLL 9 -  
Run display line 3  
> No Display <  
CHOICE ENTER
```

Password: OPERATOR

Default: NO DISPLAY
Selections: NO DISPLAY, LOAD, SPEED, DATE/TIME (Only if COMM board installed)

3.4.2 COMM A Scroll Set-Up

Main Menu 5 is dedicated to the serial options. COMM A is used to set up the serial line of the COMM A board, regardless if the serial line is connected to a computer or a PLC or for printing. The PRINT scroll is used for setting up the printer, and it only appears if the COMM A is set for printer. (See Section 3.6.4 for printer setup.)

```
- MAIN MENU 5 -  
Press MENU for more  
  
COMM A PRINT
```

1. Line Setting and Protocol Definition

Two COMM A boards can be installed and programmed, typically one for the printer and one for the supervisor.

The following screens define the communication parameters for the first and the second channel.

```
- COMM. A SCROLL 1 -  
Baud rate port #1  
> 2400 <  
CHOICE ENTER
```

Password: SERVICE

Default: 9600
Selections: 110, 150, 300, 600, 1200, 2400, 4800, 9600, 19200

```
- COMM. A SCROLL 2 -  
Set parity port #1  
> No parity <  
CHOICE ENTER
```

Password: SERVICE

Default: NO PARITY
Selections: EVEN PARITY, ODD PARITY, NO PARITY

```
- COMM. A SCROLL 3 -  
Stop bits port #1  
> 1 <  
CHOICE ENTER
```

Password: SERVICE

Default: 1
Selections: 1, 2

```
- COMM. A SCROLL 4 -  
Wordlength port #1  
> 8 <  
CHOICE ENTER
```

Password: SERVICE

Default: 8
Selections: 7, 8

The next screen defines the port use. Some commonly used protocols are implemented in the system. Possible selections are:

- PC-MASTER Ramsey proprietary protocol: Multidrop, Master Slave.
- SIEMENS 3964R A proprietary protocol of Siemens. Point to point, Multi Master.
- ALLEN-BRADLEY A proprietary protocol of Allen-Bradley. Multidrop, Master Slave.
- DF1

MODBUS A proprietary protocol of AEG. Multidrop, Master Slave.

PRINTER Not a protocol, selects printer output.

```
- COMM. A SCROLL 5 -  
Protocol port #1  
> PC Master <  
CHOICE    ENTER
```

Password: SERVICE

Default: PRINTER
Selections: PC-MASTER, SIEMENS 3964R, ALLEN-BRADLEY DF1,
 MODBUS, PRINTER

3.4.3 Multidrop Operator Set-Up

If the selected protocol is not PRINTER, the following screens define the ADDRESS of the device in the multidrop line, and the access permission from the remote supervisor. If NONE is selected, the supervisor has full access to the device. If LIMITED is selected, the supervisor accesses only those variables that are accessible with the OPERATOR password. If PROTECTED is selected, the unit is write protected.

NOTE: This section only applies to multidrop operation. If you are using the COMM option for connecting a printer, skip this section and refer to Section 3.4.4.

The Clear To Send (CTS) line of the port can be used for hardware handshake. Select Enabled if you want to connect the CTS input of the system to a control signal generated by the other device.

WARNING

THE CTS INPUT CAN ONLY BE USED WHEN JUMPERS ARE SET FOR RS232. ATTEMPTING TO ENABLE THE CTS SOFTWARE CONTROL IN RS485 MODE WILL RESULT IN LOCK-UP OF THE LINE.

```
- COMM. A SCROLL 6-  
CLEAR TO SEND #1  
> Disactive <  
CHOICE    ENTER
```

Password: SERVICE

Default: DISACTIVE
Selections: ACTIVE, DISACTIVE

The following screens define the ADDRESS of the device in the multidrop line, and the access permission from the remote supervisor. If NONE is selected, the supervisor has full access to the device. If LIMITED is selected, the supervisor

can only access those variables that are accessible with the OPERATOR password. If PROTECTED is selected, the unit is read only to the supervisor.

```
- COMM. A SCROLL 7 -  
Address port #1  
  1  
ENTER
```

Password: SERVICE

Default: 1
Min: 1
Max: 255

```
- COMM. A SCROLL 8 -  
Access prot port #1  
> None <  
CHOICE ENTER
```

Password: SERVICE

Default: NONE
Selections: NONE, LIMITED, PROTECTED

3.4.4 Second COMM A Board

If a second COMM A board is installed, the following screen appears. These screens operate exactly as the ones dedicated to the COMM A board 1.

```
- COMM. A SCROLL 9 -  
Baud rate port #2  
> 2400 <  
CHOICE ENTER
```

Password: SERVICE

Default: 9600
Selections: 110, 150, 300, 600, 1200, 2400, 4800, 9600, 19200

```
- COMM. A SCROLL 10-  
Set parity port #2  
> No parity <  
CHOICE ENTER
```

Password: SERVICE

Default: NO PARITY
Selections: EVEN PARITY, ODD PARITY, NO PARITY

```
- COMM. A SCROLL 11-  
Stop bits port #2  
> 1 <  
CHOICE ENTER
```

Password: SERVICE

Default: 1
Selections: 1, 2

```
- COMM. A SCROLL 12-  
Wordlength port #2  
> 8 <  
CHOICE ENTER
```

Password: SERVICE

Default: 8
Selections: 7, 8

```
- COMM. A SCROLL 13-  
Protocol port #2  
> PC Master <  
CHOICE ENTER
```

Password: SERVICE

Default: PRINTER
Selections: PC-MASTER, SIEMENS 3964R, ALLEN BRADLEY DF1, MODBUS,
PRINTER

Only if protocol of port #2 is not PRINTER:

```
- COMM. A SCROLL 14-  
CLEAR TO SEND #2  
> Disactive <  
CHOICE ENTER
```

Password: SERVICE

Default: DISACTIVE
Selections: ACTIVE, DISACTIVE

```
- COMM. A SCROLL 15-  
Address port #2  
1  
ENTER
```

Password: SERVICE

Default: 1
Min: 1
Max: 255

```
- COMM. A SCROLL 16-  
Access prot port #2  
> None <  
CHOICE ENTER
```

Password: SERVICE

Default: NONE
Selections: NONE, LIMITED, PROTECTED

3.4.5 Printer Set-Up

NOTE: This section only applies to printer. If you are using the COMM option for connecting a computer, PLC or other device using a protocol, skip this section and refer to Section 3.4.3.

The Micro-Tech 2104 has a fully programmable printer format. The following section explains how to program the Print scroll according to the specific needs.

The system can be configured to operate without any handshake (NONE), or using the Clear To Send signal (CTS) or the XON-XOFF sequence. Refer to the instruction manual of the printer to define which selection is required. The selection NONE is only supplied for testing purposes, but is not recommended for normal use. If NONE is selected, the system is not able to recognize if the printer is on line or not, or if the paper is empty.

The most commonly used protocol is the CTS, which is a signal generated by the printer to indicate whether it is ready to receive data or not.

WARNING

THE CTS INPUT CAN ONLY BE USED WHEN JUMPERS ARE SET FOR RS232. ATTEMPTING TO ENABLE THE CTS SOFTWARE CONTROL IN RS485 MODE WILL RESULT IN LOCK-UP OF THE LINE.

```
- PRINTER SCROLL 1 -  
Handshaking  
> None <  
CHOICE ENTER
```

Password: SERVICE

Default: NONE
Selections: NONE, CTS, XON-XOFF

Different printers use different end of line patterns. Select the one you need according to the printer.

```
- PRINTER SCROLL 2 -  
End of line  
> CR <  
CHOICE ENTER
```

Password: SERVICE

Default: CR
Selections: CR, LF, CR+LF

Some simple printers cannot accept characters while they are printing. In some cases the handshake is not well controlled by the printer, so a delay at end of line is helpful.

```
- PRINTER SCROLL 3 -  
Delay end of line  
0 sec  
ENTER
```

Password: SERVICE

Default: 0 sec
Min: 0 sec
Max: 5 sec

A Form Feed character can be sent to the printer after each report to force the printer to eject the paper.

```
- PRINTER SCROLL 4 -  
Form Feed  
> NO <  
CHOICE ENTER
```

Password: SERVICE

Default: NO
Selections: NO, YES

If you want to generate periodical printing, enter the number of minutes, hours or days in the following screen. By entering 0, the periodical printing is prevented. Use the INTV key to switch from minutes to hours and to days.

```
- PRINTER SCROLL 5 -  
Print interval  
0 min  
ENTER INTV
```

Password: SERVICE

Default: 0
Min: 0 min, 0 hour, 0 days

Max: 59 min, 23 hour, 365 days

The system can print at specific times during the day. Enter the time you want to obtain the printing. Use the NEXT key to scroll between the print times. Up to four discrete times may be entered. The ON/OFF key enables or disables the displayed print time.

```
- PRINTER SCROLL 6 -  
Print time # 1  
time HH:MM  
ENTER ON/OFF NEXT
```

Password: OPERATOR

Default: OFF
Min: 00:00
Max: 23:59

3.4.6 Define Printing Format

By selecting YES in the following screen, the system is instructed to print one line each time a new alarm condition occurs. The alarm is printed as follows:

```
xx-xx-xxxx yy:yyz  
kkkkkkkkkkkkkkkkkkkk
```

where:

xx-xx-xxxx	Day, Month, Year, printed according to the local format as defined in Main Menu 2 - Display.
yy:yyz	Hour, Minutes, am/pm printed according to the local format as defined in Main Menu 2 - Display
kkkkkkkkkkkkkkkkkkkk	Alarm message, same message appearing on the screen.

For example:

```
12-10-1998 8:14a  
High rate
```

```
- PRINTER SCROLL 7 -  
Print alarms  
> No <  
CHOICE ENTER
```

Password: SERVICE

Default: NO
Selections: NO, YES

If YES is selected, the system prints all alarms that have been set to alarm in the Alarm scroll.

There are two ways for defining the printing format. The first is to use the predefined format. (See Section 3.3.)

Select DEFAULT if you want the predefined format. Select USER DEFINED if you want to set up your own format.

```
- PRINTER SCROLL 8 -  
Totals Report format  
> Default <  
CHOICE ENTER
```

Password: SERVICE

Default: DEFAULT
Selections: DEFAULT, USER DEFINED

If your selection is USER DEFINED, the following screens are displayed.

Define if you want to add a heading string in your report. String can be used to add the Customer name as well as other information that you want to include in the print format.

```
- PRINTER SCROLL 9A-  
Contents string #1  
XXXXXXXXXXXXXXXXXXXXXXXXX  
< ENTER >
```

Password: OPERATOR

Default: XXXXXXXXXXXXXXXXXXXXX

Once you have defined the string, you have to specify where the string is to be placed on the printed report. The coordinate is given in the following way:

```
00000000001111111112222222223...  
0123456789012345678901234567890...  
+-----> Y  
00|This line printed first  
01|This line printed second  
02|  
03|  
04|  
05|  
06|  
. v  
. X
```

^
| DIRECTION OF
| PAPER

Use the X-pos and Y-pos keys to enter the X and Y coordinates. Confirm with ENTER. By specifying 0,0, the string is not printed.

```
- PRINTER SCROLL 9B-  
Position string #1  
X = 0 , Y = 0  
ENTER X-pos Y-pos
```

Password: OPERATOR

Default: 1, 1
Min: 0, 1
Max: 24, 80

If you specified more strings, enter the relevant data using the same procedure.

```
- PRINTER SCROLL 10-  
String #2  
> yes <  
CHOICE ENTER
```

Password: OPERATOR

Default: NO
Selections: YES, NO

If you selected YES, the next two scrolls are displayed.

```
- PRINTER SCROLL 10A-  
Contents string #2  
XXXXXXXXXXXXXXXXXXXXXXXXX  
< ENTER >
```

Password: OPERATOR

Default: XXXXXXXXXXXXXXXXXXXXX

```
- PRINTER SCROLL 10B-  
Position string #2  
X = 0 , Y = 0  
ENTER X-pos Y-pos
```

Password: OPERATOR

Default: 2, 1
Min: 0, 1
Max: 24, 80

There is a third string. If only one scale is defined, it is a third heading string exactly as the previous two. If more scale are defined, it may be used to define a scale identifier. String definition is different for each scale and it is used as scale heading.

```
- PRINTER SCROLL 11-
String #3
  > yes <
CHOICE  ENTER
```

Password: OPERATOR

Default: NO
 Selections: YES, NO

If you selected YES, the next two scrolls are displayed. The SCALE# key allows the operator to select the scale.

```
- PRINTER SCROLL 11A-
Contents string #3
XXXXXXXXXXXXXXXXXXXXX
<      ENTER      >
```

Password: OPERATOR

Default: XXXXXXXXXXXXXXXXXXXXX

```
- PRINTER SCROLL 11B-
Position string #3
X = 0      ,      Y = 0
ENTER  X-pos  Y-pos
```

Password: OPERATOR

Default: 3, 1
 Min: 0, 1
 Max: 24, 80

A series of variables can be added in the report. Variables are: MASTER TOTAL, RESET TOTAL, DATE, TIME, WEIGHT, and RATE. The position must be defined for each variable. If you do not intend to add a variable in the report, you should set its X position to 0.

```
- PRINTER SCROLL 12 -
Date position
X =      ,      Y =     
ENTER      X\Y-pos
```

Password: OPERATOR

	X	Y
Default:	4,	1
Min:	0,	1
Max:	24,	80

```
- PRINTER SCROLL 13 -  
Time position  
X = __ , Y = __  
ENTER      X\Y-pos
```

Password: OPERATOR

	X	Y
Default:	5,	1
Min:	0,	1
Max:	24,	80

```
- PRINTER SCROLL 14 -  
Reset total pos.  
X = __ , Y = __  
ENTER      X\Y-pos
```

Password: OPERATOR

	X	Y
Default:	6,	1
Min:	0,	1
Max:	24,	80

```
- PRINTER SCROLL 15 -  
Master total pos.  
X = __ , Y = __  
ENTER      X\Y-pos
```

Password: OPERATOR

	X	Y
Default:	7,	1
Min:	0,	1
Max:	24,	80

```
- PRINTER SCROLL 16 -  
Weight position  
X = __ , Y = __  
ENTER      X\Y-pos
```

Password: OPERATOR

	X	Y
Default:	0,	1
Min:	0,	1
Max:	24,	80

- PRINTER SCROLL 17 -
Rate position
X = , Y =
ENTER X\Y-pos

Password: OPERATOR

	X	Y
Default:	0,	1
Min:	0,	1
Max:	24,	80

3.5 COMMUNICATION PROTOCOLS

The communication protocol allows a remote intelligent device to read and eventually write the contents of the registers as listed in this section.

During the communication activity, the Micro-Tech 2104 always acts as Slave, meaning that it will respond to a request from a Master device on the line, but never attempts to send messages out.

The instrument responds only if the message is completely received. The instrument reads the message and looks for the address, which is contained in an address byte in the query package. The message is then processed only if the address contained in the message matches the address specified in the set-up data of the instrument. When the system receives a message, the integrity of it is checked, and an answer message is prepared if yes.

The Master must respect a 100 ms interval time between two messages. If a message is sent before 100 ms have passed since the previous one, it is lost. (The data is received by an interrupt routine, while it is processed in a task which is executed each 100 ms.)

If the Master sends variables to be written in memory, the system checks the correctness of the message, and immediately sends an answer message if it is correct. This does not necessarily mean that the data is written in memory. The system first checks the address, which must correspond to a valid address of a variable, then the minimum and maximum limits are checked, and then the password. If data can be accepted, the success flag is set to 0 (no error), if not, it is set to 1. The Master needs to check the success flag (contained into a read only register), to know if the last variables sent have been stored or not.

The procedure is as follows:

- Send the data to the Micro-Tech 2104
- Wait 100 ms
- Read the success flag, should be 0.

Some data is read only, some is read write, some is write only.

NOTE: The maximum number of words the system can transfer is 41 per time. Requests of registers in excess of 41 are treated as errors and do not generate an answer.

NOTE: This section only applies to multidrop operation. If you are using the COM option for connecting a Printer, skip this section and refer to Section 3.3.4.

3.5.1 Registers Definition

The following registers can be accessed through a serial line link using one of the available communication protocols. The table lists the registers specifying per each:

- register	A conventional name		
- type	Can be:	RO	The register can be read but cannot be written.
		RW	The register can be read or written. Write is allowed if the instrument is in the specified protection level at the moment the write message is received.
		WO	The register can only be written. Write is subject to protection control.
- low limit	The minimum acceptable value for the variable. Lower values are considered as errors.		
- high limit	The maximum acceptable value for the variable. Higher values are considered as errors.		
- refresh time	The time between two updates of the variable in the instrument's memory.		
- protection	The minimum protection level which must be in place to allow access to the variable:		
- always available			
	limited	available if limited or service	
	service	available if service only	
- format	Can be:	char	An ASCII string
		integer	16 bits IEEE integer
		float	32 bits IEEE float

WARNING

THE ACTUAL ADDRESS OF EACH REGISTER IS DEFINED DIFFERENTLY FOR EACH PROTOCOL AS EXPLAINED IN THE FOLLOWING SECTIONS.

3.5.2 Type, Limits and Format of Registers

register	type	low limit	high limit	refresh time [ms]	protection	format
success_flag	RO	-	-	-	none	integer
display	RO	-	-	100	-	char
leds	RO	-	-	100	-	integer
status	RO	-	-	100	-	integer
alarms	RO	-	-	100	-	integer
i_o	RO	-	-	100	-	integer
commands	WO	0	32767	100	none	integer
batch_number	RW	0	999	100	limited	integer
batch_dev	RW	0	100	-	limited	integer
batch_set	RW	0	10000	-	limited	float
batch_preset	RW	0	10000	-	limited	float
batch_preset_sp	RW	0	100.0	-	limited	float
batch_preact	RW	0	10000	-	limited	integer
batch_total	RO	-	-	100	-	float
master_total	RO	-	-	100	-	float
reset_total	RW	0 (1)	0 (1)	100	none	float
rate	RO	-	-	100	-	float
weight	RO	-	-	100	-	float
rate_cap	RO	1	-	-	service	float
scale_cap	RO	1	-	-	service	float
h_rate_set	RW	0	105.0%	-	limited	float
l_rate_set	RW	0	105.0%	-	limited	float

register	type	low limit	high limit	refresh time [ms]	protection	format
h_weight_set	RW	0	105.0%	-	limited	float
l_weight_set	RW	0	105.0%	-	limited	float
h_pos_dev_set	RW	0	105.0%	-	limited	float
hh_pos_dev_set	RW	0	105.0%	-	limited	float
h_neg_dev_set	RW	0	105.0%	-	limited	float
hh_neg_dev_set	RW	0	105.0%	-	limited	float
start_ref	RW	0	105.0%	-	limited	float
end_ref	RW	0	105.0%	-	limited	float
ing_ratio	RW	0	100.0%		limited	float
Control_set	RW	0	rate_cap (2)	min_rate (2)	limited	float
Control_dev	RO	0	100.0%	-	limited	float

(1) Can only be zeroed.

(2) rate_cap and min_rate are the maximum and minimum rate defined in the SYSTEM scroll.

3.5.3 Description of Registers

In the following section an explanation is given per each variable of the above table.

a. success_flag

Set to 0 after a message has been received and properly processed. If a message is correctly received but cannot be processed because password protection or size error, this flag is set to 1. The user may read this register after a write message to ensure the data have been accepted.

b. display

It contains the messages actually shown on the display of the instrument in form of an ASCII string. For example, the screen:

```

-      MENU MAIN 1      -
PRESS MENU FOR MORE
ZERO   SPAN   MAT'L
CAL    CAL    CAL

```

Will be stored in registers in the following way:

display(1)	2DH	20H	Characters 1 and 2 from left of first row
display(2)	4DH	45H	
display(3)	4EH	55H	
display(4)	20H	4DH	
display(5)	41H	49H	
display(6)	4EH	20H	
...			
display(10)	Characters 19 and 20 from left of first row
display(11)	Characters 1 and 2 from left of second row
...			
display(20)	Characters 19 and 20 from left of second row
display(21)	Characters 1 and 2 from left of third row
...			
display(30)	Characters 19 and 20 from left of third row
display(31)	Characters 1 and 2 from left of fourth row
...			
display(38)	4CH	20H	
display(39)	20H	20H	
display(40)	20H	20H	Characters 19 and 20 from left of fourth row

c. leds

Leds(1)	<u>bit</u>	<u>description</u>
	15	not used
	.	
	.	
	05	not used
	04	led 5 (1 = on, 0 = off)
	03	led 4
	02	led 3
	01	led 2
	00	led 1

d. status

Status(1)	<u>bit</u>	<u>description</u>
	15	cumulative shutdown (a shutdown alarm is pending)
	14	cumulative alarms (an alarm is pending)
	13	calibration running
	12	Auto
	11	Remote

- 10 Refilling
- 09 Running
- 08 Not used
- 07 High weight (weight is higher than limit)
- 06 Low weight (Load is lower than limit)
- 05 High rate (Rate is higher than limit)
- 04 Low rate (Rate is lower than limit)
- 03 High positive deviation (regulation error higher than limit)
- 02 High high positive deviation (regulation error higher than)
- 01 High negative deviation (regulation error higher than limit)
- 00 High high negative deviation (regulation error higher than limit)

Status(2) Batch status. Only applicable if Load Out option installed.

- xxs0 H Batch not running
- xxs H Not used
- xxs2 H Batch running at high rate
- xxs3 H Batch running at low rate
- xxs4 H Waiting start delay time
- xxs5 H Waiting stabilization time

- s can be 0 Normal status
- 1 Stand by status

e. alarms

In the alarms register, each bit represents the status of an alarm. If the alarm is active, the relevant bit contains '1', otherwise it contains '0'. For more clarity, the alarm bits are split into two tables. Refer to the first if your system is configured for work with only one scale, refer to the second if your system has two scales.

For SINGLE SCALE SYSTEM:

alarms (1)	<u>bit</u>	<u>description</u>
	15	CLOCK FAIL
	14	CELL FAIL
	13-12	Not used
	11	RAM FAIL
	10	ROM FAIL
	09	HIGH WEIGHT
	08-07	Not used
	06	LOW WEIGHT
	03	HIGH RATE

	02-01	Not used
	00	LOW RATE
alarms (2)	<u>bit</u>	<u>description</u>
	15-14	Not used
	13	WARM START
	12	COLD START
	11	PWD DURING CALIB
	10	CAL TIME ELAPSED
	09-08	Not used
	07	EXTERN ALARM 1
	06	EXTERN ALARM 2
	05	EXTERN ALARM 3
	04	HW CNF CHANGE SLOT 1
	03	HW CNF CHANGE SLOT 2
	02	HW CNF CHANGE SLOT 3
	01	HW CNF CHANGE SLOT 4
	00	HW CNF CHANGE SLOT 5
alarms (3)	<u>bit</u>	<u>description</u>
	15	HW CNF CHANGE SLOT 6
	14	BCD OVERFLOW
	13	MATHEMATIC ERROR
	12	PRINTER ERROR
	11	COMMUNICATION ERROR
	10	HIGH POSITIVE DEV
	09-08	Not used
	07	HIGH HIGH POSITIVE DEV
	06-05	Not used
	04	HIGH NEGATIVE DEV
	03-02	Not used
	01	HIGH HIGH NEGATIVE DEV
alarms (4)	<u>bit</u>	<u>description</u>
	15	Not used
	14	REFILL TIMEOUT
	13-12	Not used
	11	OVERFLOW TOTALIZER
	10-09	Not used
	08	BATCH DEVIATION
	07-00	Not used

f. i_o

The instrument has physical inputs and outputs to which logical input and output functions are associated. As far as communication is concerned, only the status of physical inputs and outputs are transferred.

<u>i_o (1)</u>	<u>bit</u>	<u>description</u>
	15-04	not used
	03	in 3 - mother board
	02	in 2 - mother board
	01	in 1 - mother board
	00	in 0 - mother board
<u>i_o (2)</u>	<u>bit</u>	<u>description</u>
	15	in 3 board 4in/16out #1
	14	in 2 board 4in/16out #1
	13	in 1 board 4in/16out #1
	12	in 0 board 4in/16out #1
	11	in 3 board 4in/16out #2
	10	in 2 board 4in/16out #2
	09	in 1 board 4in/16out #2
	08	in 0 board 4in/16out #2
	07	in 3 board 4in/16out #3
	06	in 2 board 4in/16out #3
	05	in 1 board 4in/16out #3
	04	in 0 board 4in/16out #3
	03	in 3 board 4in/16out #4
	02	in 2 board 4in/16out #4
	01	in 1 board 4in/16out #4
	00	in 0 board 4in/16out #4
<u>i_o (3)</u>	<u>bit</u>	<u>description</u>
	15	in 15 board 16in/4out #1
	14	in 14 board 16in/4out #1
	13	in 13 board 16in/4out #1
	12	in 12 board 16in/4out #1
	11	in 11 board 16in/4out #1
	10	in 10 board 16in/4out #1
	09	in 09 board 16in/4out #1
	08	in 08 board 16in/4out #1
	07	in 07 board 16in/4out #1

06	in 06	board 16in/4out #1
05	in 05	board 16in/4out #1
04	in 04	board 16in/4out #1
03	in 03	board 16in/4out #1
02	in 02	board 16in/4out #1
01	in 01	board 16in/4out #1
00	in 00	board 16in/4out #1

i_o (4)

<u>bit</u>		<u>description</u>
15	in 15	board 16in/4out #2
14	in 14	board 16in/4out #2
13	in 13	board 16in/4out #2
12	in 12	board 16in/4out #2
11	in 11	board 16in/4out #2
10	in 10	board 16in/4out #2
09	in 09	board 16in/4out #2
08	in 08	board 16in/4out #2
07	in 07	board 16in/4out #2
06	in 06	board 16in/4out #2
05	in 05	board 16in/4out #2
04	in 04	board 16in/4out #2
03	in 03	board 16in/4out #2
02	in 02	board 16in/4out #2
01	in 01	board 16in/4out #2
00	in 00	board 16in/4out #2

i_o (5)

<u>bit</u>		<u>description</u>
15	in 15	board 16in/4out #3
14	in 14	board 16in/4out #3
13	in 13	board 16in/4out #3
12	in 12	board 16in/4out #3
11	in 11	board 16in/4out #3
10	in 10	board 16in/4out #3
09	in 09	board 16in/4out #3
08	in 08	board 16in/4out #3
07	in 07	board 16in/4out #3
06	in 06	board 16in/4out #3
05	in 05	board 16in/4out #3
04	in 04	board 16in/4out #3
03	in 03	board 16in/4out #3

	02	in 02	board 16in/4out #3
	01	in 01	board 16in/4out #3
	00	in 00	board 16in/4out #3
i_o (6)	<u>bit</u>	<u>description</u>	
	15	in 15	board 16in/4out #4
	14	in 14	board 16in/4out #4
	13	in 13	board 16in/4out #4
	12	in 12	board 16in/4out #4
	11	in 11	board 16in/4out #4
	10	in 10	board 16in/4out #4
	09	in 09	board 16in/4out #4
	08	in 08	board 16in/4out #4
	07	in 07	board 16in/4out #4
	06	in 06	board 16in/4out #4
	05	in 05	board 16in/4out #4
	04	in 04	board 16in/4out #4
	03	in 03	board 16in/4out #4
	02	in 02	board 16in/4out #4
	01	in 01	board 16in/4out #4
	00	in 00	board 16in/4out #4
i_o (7)	<u>bit</u>	<u>description</u>	
	15-04	not used	mother board
	03	out 3	mother board
	02	out 2	mother board
	01	out 1	mother board
	00	out 0	mother board
i_o (8)	<u>bit</u>	<u>description</u>	
	15	out 3	board 16in/4out #1
	14	out 2	board 16in/4out #1
	13	out 1	board 16in/4out #1
	12	out 0	board 16in/4out #1
	11	out 3	board 16in/4out #2
	10	out 2	board 16in/4out #2
	09	out 1	board 16in/4out #2
	08	out 0	board 16in/4out #2
	07	out 3	board 16in/4out #3
	06	out 2	board 16in/4out #3
	05	out 1	board 16in/4out #3

	04	out 0	board 16in/4out #3
	03	out 3	board 16in/4out #4
	02	out 2	board 16in/4out #4
	01	out 1	board 16in/4out #4
	00	out 0	board 16in/4out #4
i_o (9)	<u>bit</u>	<u>description</u>	
	15	out 15	board 4in/16 out #1
	14	out 14	board 4in/16 out #1
	13	out 13	board 4in/16 out #1
	12	out 12	board 4in/16 out #1
	11	out 11	board 4in/16 out #1
	10	out 10	board 4in/16 out #1
	09	out 09	board 4in/16 out #1
	08	out 08	board 4in/16 out #1
	07	out 07	board 4in/16 out #1
	06	out 06	board 4in/16 out #1
	05	out 05	board 4in/16 out #1
	04	out 04	board 4in/16 out #1
	03	out 03	board 4in/16 out #1
	02	out 02	board 4in/16 out #1
	01	out 01	board 4in/16 out #1
	00	out 00	board 4in/16 out #1
i_o (10)	<u>bit</u>	<u>description</u>	
	15	out 15	board 4in/16 out #2
	14	out 14	board 4in/16 out #2
	13	out 13	board 4in/16 out #2
	12	out 12	board 4in/16 out #2
	11	out 11	board 4in/16 out #2
	10	out 10	board 4in/16 out #2
	09	out 09	board 4in/16 out #2
	08	out 08	board 4in/16 out #2
	07	out 07	board 4in/16 out #2
	06	out 06	board 4in/16 out #2
	05	out 05	board 4in/16 out #2
	04	out 04	board 4in/16 out #2
	03	out 03	board 4in/16 out #2
	02	out 02	board 4in/16 out #2
	01	out 01	board 4in/16 out #2

	00	out 00	board 4in/16 out #2
i_o (11)	<u>bit</u>	<u>description</u>	
	15	out 15	board 4in/16 out #3
	14	out 14	board 4in/16 out #3
	13	out 13	board 4in/16 out #3
	12	out 12	board 4in/16 out #3
	11	out 11	board 4in/16 out #3
	10	out 10	board 4in/16 out #3
	09	out 09	board 4in/16 out #3
	08	out 08	board 4in/16 out #3
	07	out 07	board 4in/16 out #3
	06	out 06	board 4in/16 out #3
	05	out 05	board 4in/16 out #3
	04	out 04	board 4in/16 out #3
	03	out 03	board 4in/16 out #3
	02	out 02	board 4in/16 out #3
	01	out 01	board 4in/16 out #3
	00	out 00	board 4in/16 out #3

	15	out 15	board 4in/16 out #4
i_o (12)	<u>bit</u>	<u>description</u>	
	14	out 14	board 4in/16 out #4
	13	out 13	board 4in/16 out #4
	12	out 12	board 4in/16 out #4
	11	out 11	board 4in/16 out #4
	10	out 10	board 4in/16 out #4
	09	out 09	board 4in/16 out #4
	08	out 08	board 4in/16 out #4
	07	out 07	board 4in/16 out #4
	06	out 06	board 4in/16 out #4
	05	out 05	board 4in/16 out #4
	04	out 04	board 4in/16 out #4
	03	out 03	board 4in/16 out #4
	02	out 02	board 4in/16 out #4
	01	out 01	board 4in/16 out #4
	00	out 00	board 4in/16 out #4

g. commands

Each bit of the commands register is specified as follows:

<u>Bit</u>	<u>Description</u>	<u>Action</u>
15-12	Not used	
11	Stand by Batch	Only if Load Out option installed. Temporarily stops a Load Out (batch) sequence. Batch can resume if a Start command is sent later.
10	Stop Batch	Only if Load Out option installed. Stops a Load Out (batch) sequence.
09	Start Batch	Only if Load Out option installed. Starts a Load Out (batch) sequence.
08-02	Not used	
01	Clear RESET total	
00	Reset Alarms	Reset any pending alarm

In order to give a command, the Host must set the relevant bit to 1 and write (send) the register to the instrument. The action is performed if the write message is accepted.

NOTE: The registers from h. to n. only apply if the optional Load Out option is installed.

h. Batch_number

The number of the currently running load out or the number of the last finished one. The integrator will automatically increment the batch number when a new batch is started.

i. Batch_dev

The maximum acceptable deviation from the batch set point. Usually entered by the user.

j. Batch_set

The set point for the current or the next load out. Usually entered or downloaded by the user.

k. Batch_preset

The pre-set point for the current or the next load out. Set by the user, defines when the rate will be lowered to increase batch accuracy.

l. Batch_preset_sp

Is the reduction in percent of the regulation setpoint when the batch reaches the preset value.

- m. Batch_preact
The set point of the pre act for the current or the next load out. Entered or downloaded by the user (if in MANUAL mode) or calculated by the integrator. Defines when the load out has to stop to compensate the queue of material from the loading point to the scale.
- n. Batch_total
The current contents of the load out totalizer. Usually read at end of batch to check the result of the load out. This register is automatically cleared when a new batch is started.
- o. Master_total
The current value of the master totalizer.
- p. Reset_total
The current value of the reset totalizer. Reset total can be zeroed by writing zero to this register or by the command register.
- q. Rate
The instantaneous rate in engineering units as currently displayed on the RUN screen.
- r. Weight
The instantaneous weight in engineering units.
- s. Rate_cap
The rate capacity of the loss in weight system. Entered by the user at first start up, should never be altered.
- t. Scale_cap
The scale capacity of the scale. Entered by the user at first start up, should never be altered.
- u. H_rate_set
The set point for the alarm of high rate. Entered or downloaded by the user.
- v. L_rate_set
The set point for the alarm of low rate. Entered or downloaded by the user.
- w. H_weight_set
The set point for the alarm of high weight. Entered or downloaded by the user.
- x. L_weight_set
The set point for the alarm of low weight. Entered or downloaded by the user.
- y. Hpos_dev_set

The set point for the alarm of high positive deviation. Entered or downloaded by the user.

z. Hhpos_dev_set

The set point for the alarm of high high positive deviation. Entered or downloaded by the user.

aa. Hneg_dev_set

The set point for the alarm of high negative deviation. Entered or downloaded by the user.

ab. Hhneg_dev_set

The set point for the alarm of high high negative deviation. Entered or downloaded by the user.

ac. Start_ref

The set point to start the refill phase. Entered or downloaded by the user.

ad. End_ref

The set point to end the refill phase. Entered or downloaded by the user.

ae. Ing_ratio

The percent of ingredient for the remote (analog input) regulation setpoint.

af. Control_set

When read it is the actual regulation set point in rate units. When write it is the remote regulation set point. It will be used by the instrument when it is switch in remote.

ag. Control_dev

It is the actual regulation error in percent.

3.6 PC-MASTER PROTOCOL

The PC-Master protocol is fully described in the following manual (available from Ramsey on request):

PC-MASTER COMMUNICATION PROTOCOL Rev 08.01.1996

The following messages are used to communicate with the MT2104 type of instruments:

- Message #97: Send a Key to the MT2104
- Message #98: Send variables to the MT2104
- Message #99: Get variables from the MT2104

3.6.1 Description

1. Message #97: SEND A KEY TO THE MT2104

With this command, the code of one key can be sent to the instrument. When the keys are received by the instrument, they are processed as the normal keyboard entries.

QUERY MESSAGE

Begin of frame	STX	02
	DLE	10H
Address	xxx	xxx
Code	97	61H
Stamp	xxx	xxx
Data	KEY	1 byte
Error check	xxx	xxx
End of frame	ETX	03

RESPONSE MESSAGE

No response is provided.

TABLE OF THE KEYS

<u>KEY</u>	<u>HEX CODE</u>	<u>KEY</u>	<u>HEX CODE</u>
UP ARROW	48H	EIGHT	38H
DOWN ARROW	50H	NINE	39H
DECIMAL POINT	2EH	MENU	4DH
CLEAR	53H	RUN	52H
ZERO	30H	F1	3FH
ONE	31H	F2	40H

TWO	32H	F3	41H
THREE	33H	AUTO/MAN	3BH
FOUR	34H	LOC/REM	3CH
FIVE	35H	START	3DH
SIX	36H	STOP	3EH
SEVEN	37H		

Example:

The Host sends the 'MENU' key to MT2104 (Address of Slave 1):

<u>HOST (PLC)</u>	<u>SLAVE (2104)</u>
02H 10H 01H 61H 01H 4DH B0H 03H	-->

2. Message #98: SEND A VARIABLE TO THE MT2104

With this command, the master sends registers to the slave unit.

QUERY MESSAGE

Begin of frame	STX	02
	DLE	10H
Address	xxx	xxx
Code	98	62H
Stamp	xxx	xxx
Data	Address	1 WORD
	WordCount	1 WORD
	DATA	WordCount WORDS
Error check	xxx	xxx
End of frame	ETX	03

RESPONSE MESSAGE

Begin of frame	STX	02
	DLE	10H
Address	xxx	xxx
Code	98	62H
Stamp	xxx	xxx
Data	Address	1 WORD
	WordCount	1 WORD
Error check	xxx	xxx
End of frame	ETX	03

Example:

The Host wants to write the HIGH WEIGHT SET (address 7A hex):

High weight set: 100.0 %

Address of Slave: 1

HOST (PLC)

SLAVE (2104)

02H 10H 01H 62H 01H 00H
7AH 00H 02H 42H C8H 00H
00H EAH 03H

-->

<--

02H 10H 01H 62H 01H 00H
7AH 00H 02H 50H 03H

3. Message #99: READ REGISTERS

With this command, the master asks the slave unit for registers.

QUERY MESSAGE

Begin of frame	STX	02
	DLE	10H
Address	xxx	xxx
Code	99	63H
stamp	xxx	xxx
Data	Address	1 word
	WordCount	1 word
Error check	xxx	xxx
End of frame	ETX	03

RESPONSE
MESSAGE

Begin of frame	STX	02
	DLE	10H
Address	xxx	xxx
Code	99	63H
Stamp	xxx	xxx
Data	Address	1 word
	WordCount	1 word
	DATA	n. words
Error check	xxx	xxx
End of frame	ETX	03

Example:

The Host wants to receive the HIGH WEIGHT SET (address 7A hex):

High weight set: 100.0 %

Address of Slave: 1

HOST (PLC)

SLAVE (2104)

02H 10H 01H 63H 01H 00H

7AH 00H 02H E1H 03H

-->

<--

02H 10H 01H 63H 01H 00H

7AH 00H 02H 42H C8H

00H

00H EBH 03H

3.7 SIEMENS 3964R

The protocol has been implemented as described in - "Funzioni di accoppiamento con CP 525/2 Manuale - Simatic S5" - Siemens - Rev. 1989

Two communication modes are provided:

FETCH The HOST asks the slave unit for registers

SEND The HOST sends registers to the slave

The choice between requesting or sending data is made using a specific code inside the message.

3.7.1 Write Register

<u>HOST (PLC)</u>		<u>SLAVE (2104)</u>
STX (02H)		-->
		<-- DLE (10H)
HEDING TEL HI (00H)	-->	
HEDING TEL LO (00H)		
COMAND HI (41H)		
COMAND LO (44H)		
DESTINATION DB (00H)		
DESTINATION DW (XXH)		
NUMBER BYTES HI (00H)		
NUMBER BYTES LO (XXH)		
no CF (FFH)		
all CPUs (FFH)		
DATA MSB		
....		
DATA LSB		
DLE (10H)		
ETX (03H)		
BCC (XXH)		
		<-- DLE (10H)
		STX (02H)
DLE (10H)	-->	
		<-- HEDING TEL HI (00H)
		HEDING TEL LO (00H)
		NOT USED (00H)
		NUMBER ERROR (00H)
		DLE (10H)

<u>HOST (PLC)</u>		<u>SLAVE (2104)</u>	
		ETX	(03H)
		BCC	(XXH)
DLE (10H)	-->		

Example:

The Host wants to write the HIGH LOW RATE (address 78 hex) at 100.0 %:

<u>HOST (PLC)</u>		<u>SLAVE (2104)</u>	
02H	----->		
	<-----	10H	
00H 00H 41H 44H 00H 78H			
00H 02H FFH FFH 42H C8H			
00H 00H 10H 03H E5H	----->		
	<-----	10H 02H	
10H	----->		
	<-----	00H 00H 00H 00H 10H 03H13H	
10H	----->		

3.7.2 Read Register

<u>HOST (PLC)</u>		<u>SLAVE (2104)</u>	
STX	-->		
	<--	DLE (10H)	
HEDING TEL HI (00H)	-->		
HEDING TEL LO (00H)			
COMAND HI (45H)			
COMAND LO (44H)			
DESTINATION DB (00H)			
DESTINATION DW (XXH)			
NUMBER BYTES HI (00H)			
NUMBER BYTES LO (XXH)			
no CF (FFH)			
all CPUs (FFH)			
DLE (10H)			
ETX (03H)			
BCC (XXH)			

<u>HOST (PLC)</u>		<u>SLAVE (2104)</u>
	<--	DLE (10H) STX (02H)
DLE (10H)	-->	
	<--	HEDING TEL HI (00H) HEDING TEL LO (00H) NOT USED (00H) NUMBER ERROR (XXH) DATA LSB MAX 127 BYTES DATA MSB DLE (10H) ETX (03H) BCC (XXH)
DLE (10H)	-->	

Example:

The Host wants to receive the LOW RATE SET (address 78 hex).

HIGH WEIGHT SET: 100.0 %

<u>HOST (PLC)</u>		<u>SLAVE (2104)</u>
02H	----->	
	<-----	10H
00H 00H 45H 44H 00H 78H 00H 02H FFH FFH 10H 03H 6BH	----->	
	<-----	10H
	<-----	02H
10H	----->	
	<-----	00H 00H 00H 00H 42H C8H 00H 00H 10H 03H 99H
10H	----->	

3.8 MODBUS

This protocol has been implemented as described in: - "Gould Modicon Modbus Protocol" - Reference Guide - November 1993 - Rev. A (Gould Inc. Programmable Control Division)

NOTE: Only a subset of the protocol has been implemented, as described in this chapter.

3.8.1 Read Registers

QUERY

Address	xxx
function	03H
add. hi	xxx
add. lo	xxx
n.data hi	xxx
n.data lo	xxx
crc16 lo	xxx
crc16 hi	xxx

RESPONSE MESSAGE

Address	xxx
function	03H (83H in case of error)
byte cnt	xxx
data MSB	xxx
. . .	xxx
data LSB	xxx
crc16 lo	xxx
crc16 hi	xxx

Example:

The Host wants to receive the LOW WEIGHT SET (address 125 dec):

High weight set: 20.0 %

Address of Slave: 01

HOST (PLC)

SLAVE (2104)

01H 03H 00H 7CH 00H 02H ----->
05H D3H

<----- 01H 03H 04H 00H 00H 41H A0H
CAH 1BH

Exceptions:

The instrument handles the following exceptions:

Illegal address exception code = 2 address is not correct or number of registers overlaps the max limit (42).

3.8.2 Write Registers

QUERY

Address	xxx
function	10H
add. hi	xxx
add. lo	xxx
n.data hi	xxx
n.data lo	xxx
n. bytes	xxx
data MSB	xxx
...	xxx
data LSB	xxx
crc16 lo	xxx
crc16 hi	xxx

RESPONSE MESSAGE

Address	xxx
function	10H (90H in case of error)
add. hi	xxx
add. lo	xxx
n. data hi	xxx
n. data lo	xxx
crc16 lo	xxx
crc16 hi	xxx

Example:

The Host wants to write the LOW WEIGHT SET (address 125 dec) to 20.0 %:

Address of Slave: 01

HOST (PLC)

SLAVE (2104)

01H 10H 00H 7CH 00H 02H ----->
04H 00H 00H 41H A0H C4H
F6H

<----- 01H 10H 00H 7CH 00H 02H 80H
10H

Exceptions:

The instrument handles the following exceptions:

Illegal address	exception code = 02	address is not correct or number of registers overlaps the max limit (42).
Illegal value	exception code = 03	values are out of the limits or protected.

3.8.3 Write Word

QUERY

Address	xxx
function	06H
add. hi	xxx
add. lo	xxx
value hi	xxx
value lo	xxx
crc16 lo	xxx
crc16 hi	xxx

RESPONSE MESSAGE

Address	xxx
function	06H (86H in case of error)
add. hi	xxx
add. lo	xxx
value hi	xxx
value lo	xxx
crc16 lo	xxx
crc16 hi	xxx

Example:

The Host wants to write the COMMAND word (address 92 dec) to 1 (reset alarm)

Address of Slave: 1

HOST (PLC)

SLAVE (2104)

01H 06H 00H 5DH 00H 01H ----->
D9H D8H

<----- 01H 06H 00H 5DH 00H 01H D9H
D8H

Exceptions:

The instrument handles the following exceptions:

Illegal address	exception code = 02	address is not correct or number of registers overlaps the max limit (42).
Illegal value	exception code = 03	value is out of the limits or protected.

3.9 ALLEN BRADLEY DF1 (PLC-5)

The DF1 is a proprietary protocol of Allen-Bradley. The protocol has been implemented according to: Allen-Bradley "Reference Manual - Data Highway / Data Highway Plus Protocol and Command Set".

The commands used to read or write the registers are: typed read (code 68h) and typed write (67h).

3.9.1 Read Registers

- Connect message

This message must be sent from Host to Slave before a request of sending data can be performed.

<u>HOST (PLC)</u>		<u>SLAVE (2104)</u>
DLE	(10H)	-->
SOH	(01H)	
ADDRESS OF SLAVE		
DLE	(10H)	
STX	(02H)	
ADDRESS OF SLAVE		
ADDRESS OF HOST		
COMMAND	(0FH)	
STS	(00H)	
TMS	(xxH)	
TMS	(xxH)	
FNC	(68 H)	
PACKET OFFSET (LOW)		
PACKET OFFSET (HIGH)		
TOTAL TRANS (LOW)		
TOTAL TRANS (HIGH)		
ADDRESS OF DATA (FIRST BYTE)		
ADDRESS OF DATA (SECOND BYTE)		
ADDRESS OF DATA (THIRD BYTE)		
ADDRESS OF DATA (FOURTH BYTE)		
SIZE OF DATA IN ELEMENTS (LOW)		
SIZE OF DATA IN ELEMENTS (HIGH)		
DLE	(10H)	
ETX	(03H)	
BCC		-->
		<-- DLE (10H)
		<-- ACK (06H)

- Ask data:

This message is sent from the Host to the Slave to request a certain number of data:

<u>HOST (PLC)</u>		<u>SLAVE (2104)</u>
DLE (10H)	-->	
ENQ (05H)		
ADDRESS SLAVE		
BCC		
	<--	DLE (10H)
		STX (02H)
		ADDRESS HOST
		ADDRESS SLAVE
		4FH (COMMAND)
		STS (00H)
		TMS (xxH)
		TMS (xxH)
		TYPE DATA PARAMETER
		DATA LSB MSB
		...
		DATA LSB MSB
		DLE (10H)
		ETX (03H)
		BCC
DLE (10H)	-->	
ACK (06H)	-->	

Example:

The Host wants to receive the HIGH WEIGHT SET (address F8:13):

High load set: 100.0 %

Address of Slave: 02

Address of Host: 01

<u>HOST (PLC)</u>		<u>SLAVE (2104)</u>
10H 01H 02H 10H 02H 02H	----->	
01H 0FH 00H 00H 00H 78H		
00H 00H 01H 00H 07H 00H		
08H 0AH 01H 00H 10H 03H		
69H		
	<-----	10H 06H
10H 05H 01H FFH	----->	
	<-----	10H 02H 01H 02H 4FH 00H 00H
		00H 99H 09H 06H 94H 08H 00H
		00H C8H 42H 10H 03H A2H
10H 06H	----->	

3.9.2 Write Registers

- Send data

This message is used from the Host to download registers into the Slave unit.

<u>HOST (PLC)</u>			<u>SLAVE (2104)</u>
DLE	(10H)	-->	
SOH	(01H)		
ADDRESS OF SLAVE			
DLE	(10H)		
STX	(02H)		
ADDRESS OF SLAVE			
ADDRESS OF HOST			
COMMAND	(0FH)		
STS	(00H)		
TMS	(xxH)		
TMS	(xxH)		
FNC	(67 H)		
PACKET OFFSET (LOW)			
PACKET OFFSET (HIGH)			
TOTAL TRANS (LOW)			
TOTAL TRANS (HIGH)			
ADDRESS OF DATA (FIRST BYTE)			
ADDRESS OF DATA (SECOND BYTE)			
ADDRESS OF DATA (THIRD BYTE)			
ADDRESS OF DATA (FOURTH BYTE)			
TYPE DATA PARAMETER			
DATA LSB MSB			
...			
DATA LSB MSB			
DLE	(10H)		
ETX	(03H)		
BCC			
		-->	
		<--	DLE (10H)
			ACK (06H)

- Ask if data ok:

<u>HOST (PLC)</u>		<u>SLAVE (2104)</u>
DLE (10H)	-->	
ENQ (05H)		
ADDRESS SLAVE		
BCC		
	<--	DLE (10H)
		STX (02H)
		ADDRESS OF HOST
		ADDRESS OF SLAVE
		4FH (COMMAND)
		STS (00H)
		TMS (xxH)
		TMS (xxH)
		DLE (10H)
		ETX (03H)
		BCC
DLE (10H)	-->	
ACK (06H)		

- If the message is incorrectly received, the instrument will not respond.
- The character 10H is doubled (sent two times), but it is computed once only in the BCC.

Example:

The Host wants to write the HIGH WEIGHT SET (address F8:13) to 100.0 %:

Address of Slave: 02

Address of Host: 01

<u>HOST (PLC)</u>		<u>SLAVE (2104)</u>
10H 01H 02H 10H 02H 02H		
01H 0FH 00H 00H 00H 67H		
00H 00H 01H 00H 07H 00H		
08H 0AH 99H 09H 06H 94H		
08H 00H 00H C8H 42H 10H	----->	
03H 1DH		
	<-----	10H 06H
10H 05H 02H FFH	----->	
	<-----	10H 02H 01H 02H 4FH 00H 00H
		00H 10H 03H AEH
10H 06H	----->	

3.10 REGISTER MAPPING

register	Modbus	PCMaster Siemens	Allen- Bradley	note
success_flag	33	20H	N7:0	0 successful, 1 failed.
display(1)	34	21H	N7:1	
display(2)	35	22H	N7:2	
display(3)	36	23H	N7:3	
display(4)	37	24H	N7:4	
display(5)	38	25H	N7:5	
display(6)	39	26H	N7:6	
display(7)	40	27H	N7:7	
display(8)	41	28H	N7:8	
display(9)	42	29H	N7:9	
display(10)	43	2AH	N7:10	
display(11)	44	2BH	N7:11	
display(12)	45	2CH	N7:12	
display(13)	46	2DH	N7:13	
display(14)	47	2EH	N7:14	
display(15)	48	2FH	N7:15	
display(16)	49	30H	N7:16	
display(17)	50	31H	N7:17	
display(18)	51	32H	N7:18	
display(19)	52	33H	N7:19	
display(20)	53	34H	N7:20	
display(21)	54	35H	N7:21	
display(22)	55	36H	N7:22	

register	Modbus	PCMaster Siemens	Allen- Bradley	note
display(23)	56	37H	N7:23	
display(24)	57	38H	N7:24	
display(25)	58	39H	N7:25	
display(26)	59	3AH	N7:26	
display(27)	60	3BH	N7:27	
display(28)	61	3CH	N7:28	
display(29)	62	3DH	N7:29	
display(30)	63	3EH	N7:30	
display(31)	64	3FH	N7:31	
display(32)	65	40H	N7:32	
display(33)	66	41H	N7:33	
display(34)	67	42H	N7:34	
display(35)	68	43H	N7:35	
display(36)	69	44H	N7:36	
display(37)	70	45H	N7:37	
display(38)	71	46H	N7:38	
display(39)	72	47H	N7:39	
display(40)	73	48H	N7:40	
leds	74	49H	N7:41	
status(1)	75	4AH	N7:42	
status(2)	76	4BH	N7:43	
alarm_status(1)	77	4CH	N7:44	
alarm_status(2)	78	4DH	N7:45	
alarm_status(3)	79	4EH	N7:46	

register	Modbus	PCMaster Siemens	Allen- Bradley	note
alarm_status(4)	80	4FH	N7:47	
alarm_status(5)	81	50H	N7:48	
i_o(1)	82	51H	N7:49	
i_o(2)	83	52H	N7:50	
i_o(3)	84	53H	N7:51	
i_o(4)	85	54H	N7:52	
i_o(5)	86	55H	N7:53	
i_o(6)	87	56H	N7:54	
i_o(7)	88	57H	N7:55	
i_o(8)	89	58H	N7:56	
i_o(9)	90	59H	N7:57	
i_o(10)	91	5AH	N7:58	
i_o(11)	92	5BH	N7:59	
i_o(12)	93	5CH	N7:60	
Commands	94	5DH	N7:61	
Batch_number	95	5EH	N7:62	
Batch_dev	96	5FH	N7:63	
Batch_set (1)	97	60H	F8: 0	
Batch_set (2)	98	61H		
Batch_preset (1)	99	62H	F8: 1	
Batch_preset (2)	100	63H		
Batch_preset_sp (1)	101	64H	F8: 2	
Batch_preset_sp (2)	102	65H		
Batch_preact (1)	103	66H	F8: 3	

register	Modbus	PCMaster Siemens	Allen- Bradley	note
Batch_preact (2)	104	67H		
Batch_total (1)	105	68H	F8: 4	
Batch_total (2)	106	69H		
Master_total (1)	107	6AH	F8: 5	
Master_total (2)	108	6BH		
Reset_total (1)	109	6CH	F8: 6	
Reset_total (2)	110	6DH		
Rate (1)	111	6EH	F8: 7	
Rate (2)	112	6FH		
Weight (1)	113	70H	F8: 8	
Weight (2)	114	71H		
Rate_cap (1)	115	72H	F8: 9	
Rate_cap (2)	116	73H		
Scale_cap (1)	117	74H	F8:10	
Scale_cap (2)	118	75H		
H_rate_set (1)	119	76H	F8:11	
H_rate_set (2)	120	77H		
L_rate_set (1)	121	78H	F8:12	
L_rate_set (2)	122	79H		
H_weight_set (1)	123	7AH	F8:13	
H_weight_set (2)	124	7BH		
L_weight_set (1)	125	7CH	F8:14	
L_weight_set (2)	126	7DH		
H_pos_dev_set (1)	127	7EH	F8:15	

register	Modbus	PCMaster Siemens	Allen- Bradley	note
H_pos_dev_set (2)	128	7FH		
Hh_pos_dev_set (1)	129	80H	F8:16	
Hh_pos_dev_set (2)	130	81H		
H_neg_dev_set (1)	131	82H	F8:17	
H_neg_dev_set (2)	132	83H		
Hh_neg_dev_set (1)	133	84H	F8:18	
Hh_neg_dev_set (2)	134	85H		
Start_ref (1)	135	86H	F8:19	
Start_ref (2)	136	87H		
End_ref (1)	137	88H	F8:20	
End_ref (2)	138	89H		
Ing_ratio (1)	139	8AH	F8:21	
Ing_ratio (2)	140	8BH		
Control_set (1)	141	8CH	F8:22	
Control_set (2)	142	8DH		
Control_dev (1)	143	8EH	F8:23	
Control_dev (2)	144	8FH		

CHAPTER 4.0 MAINTENANCE

4.1 GENERAL

Refer to the Micro-Tech 2104 manual for maintenance information.

CHAPTER 5.0 PARTS

5.1 GENERAL

Refer to the Micro-Tech 2105 manual for parts information.