

**Mercury Free Tilt Sensor  
User's Guide**

REC 4274 Rev. A Part Number 092241

**RAMSEY MERCURY FREE TILT SENSORS  
FOR NON-HAZARDOUS AREAS**

**CONTROL UNITS**  
*Model 20-35-NM-F*  
*Model 20-35-NM-DIN*

**PROBES**  
*Model 20-54-NM-SS*  
*Model 20-52-NM*  
*Model 20-59-NM*  
*Model 20-55-NM-P*



**Manufacturer:**  
Thermo Fisher Scientific  
501 90<sup>th</sup> Avenue NW  
55433 Minneapolis, MN (USA)  
(800) 227-8891



## Revision History

Revision Number	Date Released	ECO Number	Release Specifics
A	March 2008	1819	Manual first release

©2007 *Thermo Fisher Scientific*. All rights reserved.

This document is confidential and is the property of *Thermo Fisher Scientific*. It may not be copied or reproduced in any way without the express written consent of *Thermo*. This document also is an unpublished work of *Thermo Fisher Scientific*. *Thermo Fisher Scientific* intends to, and is maintaining the work as confidential information. *Thermo Fisher Scientific* also may seek to protect this work as an unpublished copyright. In the event of either inadvertent or deliberate publication, *Thermo Fisher Scientific* intends to enforce its rights to this work under the copyright laws as a published work. Those having access to this work may not copy, use, or disclose the information in this work unless expressly authorized by *Thermo Fisher Scientific*.

“*Microsoft*” and “*Windows*” are either registered trademarks or trademarks of *Microsoft Corporation* in the United States and/or other countries.

All other trademarks are the property of *Thermo Fisher Scientific* and its subsidiaries.

## **Software Program Licence Terms**

The Software Program is licensed, not sold. *Thermo Fisher Scientific*, grants you a license for the Software Program only in the country where you acquired the Equipment, as defined below. You obtain no rights other than those granted you under this license.

The term “Equipment” means the equipment with which the Software Program is used. The term “Software Program” means the original and all whole or partial copies of the Software Program used in connection with Equipment sold by *Thermo Fisher Scientific* to the user, including modified copies or portions of the Software Program. *Thermo Fisher Scientific* retains title to the Software Program, as well as all improvements, modifications and enhancements to the Software Program, whether made by *Thermo Fisher Scientific* or any other party. *Thermo Fisher Scientific* owns, or has licensed from the owner, copyrights in the Software Program.

You are responsible for the selection of the Equipment.

Following the commissioning of the Equipment, any change made by the user to the Software Program will terminate all warranties with respect to the Equipment and Software Program.

## **License**

Under this license, you may:

1. Use the Software Program on only one piece of equipment at any one time, unless the license information specifies otherwise;
2. Copy the Software Program for backup or in order to modify it;
3. Modify the Software Program and/or merge it into another Software Program; and
4. Subject to the following limitations, transfer the possession of the Software Program to another party, but only in connection with a transfer of the Equipment.

If you transfer the Software Program, you must transfer a copy of these License Terms, all other documentation and at least one complete, unaltered copy of the Software Program to the other party. Unless you have other copies of the Software Program to be used in connection with other Equipment purchased from *Thermo*, or one of its divisions, you must, at the same time, either transfer all your other copies of the Software Program to the transferee of the Equipment or destroy them. Your license is then terminated. The other party agrees to these terms and conditions by its first use of the Software Program.

You must reproduce the copyright notices(s) on each copy of the Software Program.

You may not:

1. Use, copy, modify, merge, or transfer copies of the Software Program except as provided in this license;
2. Reverse engineer, decompile, or disassemble the Software Program; or
3. Sub-license, rent, lease, or assign the Software Program.

### **Limitation of Remedies**

*Thermo Fisher Scientific* entire liability under this license is the following:

*Thermo Fisher Scientific* will: (a) replace defective media, or (b) make a warranted Software Program operate or (c) replace the Software Program with a functionally equivalent Software Program, as warranted.

For any claim (including breach), in any form, related in any way to this license, *Thermo Fisher Scientific's* liability will be for the actual value of the Software Program.

*Thermo Fisher Scientific* will not be liable for any lost profits, lost savings, any incidental damages, or other economic consequential damages, even if *Thermo*, or its authorized supplier, has been advised of the possibility of such damages. *Thermo Fisher Scientific* will not be liable for any damages claimed by you based on any third party claim.

### **General**

*Thermo Fisher Scientific* may terminate your license if you fail to comply with the terms and conditions of this license. In such event, you must destroy all your copies of the Software Program. You are responsible for payment of any taxes, including personal property taxes, resulting from this license.

### **Occupational Safety and Health Act (OSHA)**

The Occupational Safety and Health Act clearly places the burden of compliance on the user of the equipment and the act is generalized to the extent that determination of compliance is a judgment decision on the part of the local inspection. Hence, *Thermo Fisher Scientific* will not be responsible for meeting the full requirements of OSHA in respect to the equipment supplied or for any penalty assessed for failure to meet the requirements, in respect to the equipment supplied, of the Occupational Safety and Health Act, as interpreted by an authorized inspector. *Thermo Fisher Scientific* will use their best efforts to remedy such violation at a reasonable cost to the buyer.

## Thermo Fisher Scientific Warranty

The seller agrees, represents, and warrants that the equipment delivered hereunder shall be free from defects in material and workmanship. Such warranty shall not apply to accessories, parts, or material purchased by the seller unless they are manufactured pursuant to seller's design, but shall apply to the workmanship incorporated in the installation of such items in the complete equipment. To the extent, purchased parts or accessories are covered by the manufacturer's warranty; seller shall extend such warranty to buyer.

Seller's obligation under said warranty is conditioned upon the return of the defective equipment, transportation charges prepaid, to the seller's factory in Minneapolis, Minnesota, and the submission of reasonable proof to seller prior to return of the equipment that the defect is due to a matter embraced within seller's warranty hereunder. Any such defect in material and workmanship shall be presented to seller as soon as such alleged errors or defects are discovered by purchaser and seller is given opportunity to investigate and correct alleged errors or defects and in all cases, buyer must have notified seller thereof within two (2) years after delivery, or two (2) years after installation if the installation was accomplished by the seller.

Said warranty shall not apply if the equipment shall not have been operated and maintained in accordance with seller's written instructions applicable to such equipment, or if such equipment shall have been repaired or altered or modified without seller's approval; provided, however, that the foregoing limitation of warranty insofar as it relates to repairs, alterations, or modifications, shall not be applicable to routine preventive and corrective maintenance which normally occur in the operation of the equipment.

“EXCEPT FOR THOSE WARRANTIES SPECIFICALLY CONTAINED HEREIN, SELLER DISCLAIMS ANY AND ALL WARRANTIES WITH RESPECT TO THE EQUIPMENT DELIVERED HEREUNDER, INCLUDING THE IMPLIED WARRANTIES OF MERCHANTABILITY AND FITNESS FOR USE. THE SOLE LIABILITY OF SELLER ARISING OUT OF THE WARRANTY CONTAINED HEREIN SHALL BE EXCLUSIVELY LIMITED TO BREACH OF THOSE WARRANTIES. THE SOLE AND EXCLUSIVE REMEDY FOR BREACH OF THE WARRANTIES SET OUT ABOVE SHALL BE LIMITED TO THE REPAIR OR REPLACEMENT OF ANY DEFECTIVE ACCESSORY, PART OR MATERIAL WITH A SIMILAR ITEM FREE FROM DEFECT, AND THE CORRECTION OF ANY DEFECT IN WORKMANSHIP. IN NO EVENT SHALL SELLER BE LIABLE FOR ANY INCIDENTAL OR CONSEQUENTIAL DAMAGES.”

Purchaser agrees to underwrite the cost of any labor required for replacement; including time, travel, and living expenses of a *Thermo Fisher Scientific Field Service Engineer* at the closest factory base.

*Thermo Fisher Scientific*  
501 90th Ave. NW  
Minneapolis, MN 55433  
Phone: (800) 227-8891  
Fax: (763) 783-2525

## **Disclaimer**

Though the information provided herein is believed to be accurate, be advised that the information contained herein is not a guarantee for satisfactory results. Specifically, this information is neither a warranty nor guarantee, expressed or implied, regarding performance, merchantability, fitness, or any other matter with respect to the products, and recommendation for use of the product/process information in conflict with any patent. Please note that *Thermo Fisher Scientific* reserves the right to change and/or improve the product design and specifications without notice.

# Table of Contents

<b>Table of Contents</b> .....	<b>viii</b>
<b>List of Figures</b> .....	<b>ix</b>
<b>List of Tables</b> .....	<b>ix</b>
<b>About this Manual</b> .....	<b>xi</b>
Who Should Use this Manual?.....	xi
Standards Applied and Technical Specifications .....	xi
Organization of the Manual .....	xii
Documentation Conventions .....	xii
Safety Messages.....	xiii
General Precaution .....	xiii
Safety in Use.....	xiv
Safety in Maintenance.....	xiv
How to Get Help.....	xv
Certifications .....	xvi
<b>Chapter 1 Introduction</b> .....	<b>1-1</b>
1.1 Applications .....	1-1
1.2 Probe Models .....	1-1
1.2.1 Specifications .....	1-2
1.3 Control Units.....	1-3
1.3.1 Model 20-35-NM-F (Field Mount Version).....	1-3
1.3.2 Model 20-35-NM-DIN (Internal Cabinet Version).....	1-4
1.4 Symbol Identification .....	1-5
<b>Chapter 2 Installation</b> .....	<b>2-1</b>
2.1 Control Unit Installation .....	2-1
2.2 Probe Installation.....	2-3
2.3 Electrical Installation.....	2-8
<b>Chapter 3 Operation</b> .....	<b>3-1</b>
3.1 System Configuration .....	3-3
3.1.1 Model 20-35-NM-F Function Modes .....	3-3
3.1.2 Model 20-35-NM-F Switches Setting .....	3-4
3.1.3 Model 20-35-NM-DIN Function Modes .....	3-5
3.1.4 Model 20-35-NM-DIN Switches Setting .....	3-6
<b>Chapter 4 Maintenance and Troubleshooting</b> .....	<b>4-1</b>
4.1 Indications of Maintenance.....	4-1
4.2 Control Unit Model 20-35-NM-F Check Procedure .....	4-2
4.3 Control Unit Model 20-35-NM-DIN Check Procedure .....	4-2
<b>Chapter 5 Service Repair and Replacement Parts</b> .....	<b>5-1</b>
5.1 Parts Ordering Information .....	5-2

<b>Chapter 6 Decommissioning and Dismantling</b> .....	<b>6-1</b>
6.1 Decommissioning of the System .....	6-1
6.2 Dismantling the Unit .....	6-1
<b>Chapter 7 Labels</b> .....	<b>7-1</b>
7.1 Control Unit Mod.20-35-NM-F Labels.....	7-1
7.2 Control Unit Mod.20-35-NM-DIN Labels.....	7-2
7.3 Probe Label .....	7-3

## List of Figures

Figure 2-1: Tilt Control Unit Model 20-35-NM-F Dimensions .....	2-1
Figure 2-2: Tilt Control Unit Model 20-35-NM-DIN Dimensions.....	2-2
Figure 2-3: Tilt Sensor Model 20-54-NM-SS.....	2-4
Figure 2-4: Tilt Sensor Model 20-52-NM.....	2-5
Figure 2-5: Tilt Sensor Model 20-59-NM.....	2-6
Figure 2-6: Tilt Sensor Model 20-55-NM-P .....	2-7
Figure 2-7: Control Unit Model 20-35-NM-F Terminal Wiring .....	2-8
Figure 2-8: Control Unit Model 20-35-NM-F Internal Layout.....	2-9
Figure 2-9: Control Unit Model 20-35-NM-DIN Terminal Wiring .....	2-10
Figure 2-10: Control Unit Model 20-35-NM-DIN Internal Layout.....	2-11

## List of Tables

Table 1-1: Symbol Identification.....	1-5
Table 3-1: Model 20-35-NM-F Function Modes Switch Settings.....	3-3
Table 3-2: SW1and SW2 Settings .....	3-4
Table 3-3: SW3 Settings .....	3-4
Table 3-4: SW5 Settings .....	3-4
Table 3-5: SW4 Settings .....	3-4
Table 3-6: Model 20-35-NM-DIN Function Modes Switch Settings.....	3-5
Table 3-7 SW1 and SW2 Settings .....	3-6
Table 3-8 SW3 Settings .....	3-6
Table 3-9 SW5 Settings .....	3-6



# About this Manual

This manual contains the information necessary in order to guarantee a safety an correct use of the *Ramsey Mercury Free Tilt Sensor* system (*Control Units* with *Probe*).

Read this manual before working with the product. For personal and system safety and for best product performance, make sure you thoroughly understand the contents before using this product.

The manufacturer has a policy of constantly developing and upgrading its products and hence may make changes without prior notice.

## Who Should Use this Manual?

This manual is a learning resource and reference for specialised technical personnel concerned with installing, operating or maintaining the probe and control.

## Standards Applied and Technical Specifications

The system has been made in compliance with the EC, standards. The products are supplied complete with all the documentation required by these standards. The installation, use and maintenance manual is an integral part of this documentation and contains all the informations needed to ensure the efficient operation of the system, with particular regard to personnel safety.

The following standards have been referred to the design of the *Ramsey Mercury Free Tilt Sensor* system:

CAN/CSA-C22.2 No. 61010-1-04	Safety Requirements for electrical equipment for Measurement, Control, and Laboratory: Use- Part 1 General Requirements
UL Std. No. 61010-1	Safety Requirements for electrical equipment for Measurement, Control, and Laboratory: Use- Part 1 General Requirements
EC 93/68	Low Voltage Directive
EN 61010 : 2001	Safety Requirements for Electrical Equipment for Measurement
EN 61326-1 :2006	(EMC)

## Organization of the Manual

This manual is organized into 8 chapters.

*Chapter 1: Introduction* - provides a functional overview of the system and the technical specifications.

*Chapter 2: Installation* - provides the steps and instructions necessary to install the equipment

*Chapter 3: Operation* – provides information on equipment operation.

*Chapter 4: Maintenance and Troubleshooting* – provides information on any maintenance of the equipment and troubleshooting if appropriate.

*Chapter 5: Service, Repair, and Replacement Part* – discusses how to contact *Thermo Fisher Scientific* service departments for assistance and how to order parts for the equipment.

*Chapter 6. Decommissioning and Dismantling*

*Chapter 7 Labels* - provides information on labels description and position.

## Documentation Conventions

The following conventions are used in this manual to help easily identify certain types of information:

- *Italic* is used to introduce new terms and for emphasis.
  - *Italic/blue* type is used for references to other sections of the manual and serve as links in electronic documents.
  - The names of setup, calibration displays, menu displays, and variables are shown in **FULL CAPITALS**.
  - The names of keys are shown in **BOLD CAPITALS**.
- 
- **Note:** Provides information of special importance to the reader.
- 
-  This symbol indicates a **HINT** in the text that may be of value but not necessary for operation.

## Safety Messages

Instructions in this manual may require special precautions to ensure the safety of the personnel performing the operations.

Please read the safety information before performing any operation preceded by this symbol. 

There are two levels of safety messages: warnings and cautions. The distinction between the two is as follows:

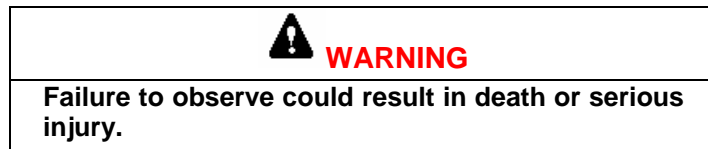

## General Precaution

Do not install, operate, or perform any maintenance procedures until you have read the safety precautions presented.

**The manufacturer is deemed absolved of all liability in the following circumstances:**

- If the products is used improperly
- If the product has not been installed in accordance with the instructions in this manual
- If the product has been installed in an environment that does not comply with the conditions set by the manufacturer
- If the product has been altered by the customer in any way without the express written authorisation of the manufacturer
- If the user has not followed the instructions given in this manual
- If the product has suffered the consequences of exceptional events such as floods, earthquakes, etc. And has been put back into operation without the necessary checks being made



### **WARNING**

**Failure to follow safe installation and servicing procedures could result in death or serious injury.**

- Make sure only qualified personnel perform installation and maintenance procedures in accordance with the instructions in this manual.
- Allow only qualified electricians to open and work in the electronics enclosure



### **WARNING**

**High voltage that may be present on leads could cause electrical shock.**

- All switches must be OFF when checking input AC electrical connections, removing or inserting printed circuit boards, or attaching voltmeters to the system.
- Use extreme caution when testing in, on, or around the electronics cabinet, PC boards, or modules. There are voltages in excess of 115 V or 230 V in these areas.



### **WARNING**

**Use only the procedures and new parts specifically referenced in this manual to ensure specification performance and certification compliance. Unauthorized procedures or parts can render the instrument dangerous to life, limb, or property.**

## **Safety in Use**

Once the products has been installed before starting work check:

- For **visible defects** on the safety devices
- For **correct operation** of the device

## **Safety in Maintenance**

Before carrying out any maintenance operation on the products it is mandatory:

- **Read** this instruction manual
- **Use** the correct tools for the maintenance operations that have to be done
- **Do not clean** the electrical parts with water or other fluid
- **On completing the repair work**, then that all the tools have been collected up



## **WARNING**

Only qualified personnel are allowed to carry out maintenance work.

Maintenance staff must wear working clothes and individual protective equipment in conformity with safety legislation and binding safety standards.

Any alteration to the product or replacement of any parts made without the manufacturer's authorisation may cause an accident hazard and absolves the manufacturer from all civil and criminal liability.

If an emergency situation arises because of a fire, it is forbidden to use water to put the fire out, always use powder-type extinguishers.

## How to Get Help



## **WARNING**

Unless you are directed to do so by an authorized service representative of *Thermo Fisher Scientific*, you should not attempt to perform any troubleshooting or maintenance procedures that are not described in this manual.

Failure to comply with these warnings can result in exposure to high voltages or high temperatures, which can cause personal injury.

# Certifications

## CONTROL UNIT

**Model : 20-35-NM-F**

### TAG MARKING

CE Certification



CE

CSA International



$-40^{\circ}\text{F} (-40^{\circ}\text{C}) \leq T_a \leq +122^{\circ}\text{F} (+50^{\circ}\text{C})$   
Master Contract : 158791

**Model : 20-35-NM-DIN**

### TAG MARKING

CE Certification



CE

CSA International



$-40^{\circ}\text{F} (-40^{\circ}\text{C}) \leq T_a \leq +122^{\circ}\text{F} (+50^{\circ}\text{C})$   
Master Contract : 158791

## **PROBE**

***Models : 20-54-NM-SS / 20-52-NM / 20-59-NM / 20-55-NM-P***

### ***TAG MARKING***

**CE Certification**



**CE**



# Chapter 1

## Introduction

This chapter describes the applications appropriate for the control units for *Mercury Free Tilt Sensor* system and their respective specifications.

### 1.1 Applications

The strong and simple structure allows for safety in operation and ease of installation. The principal use conditions are:

- Silos and hopper
- Stock pilings
- Blocking in the charge/discharge areas of conveyor belt openings
- Signal for material's presence or lack-of on a conveyor belt
- In other applications where the effect is tilt of the probe. The probe actuates when it is tilted 15 degrees or more from its vertical position.

### 1.2 Probe Models

Model 20-54-NM-SS	Stainless Steel Probe (AISI 304)
Model 20-52-NM	Heavy Duty 2" Metal Probe
Model 20-59-NM	Standard Probe, Nickel Chrome Plated Casting
Model 20-55-NM-P	Standard Probe, PVC

#### ACCESSORY AVAILABLES ON REQUEST :

For Model 20-52-NM	<i>WEAR PADDLE</i> for extension or anti-abrasion
For Model 20-59-NM	<i>WEAR PADDLE</i> for extension or anti-abrasion
	<i>STAINLESS STEEL FLOAT BALL</i>
	<i>PLASTIC FLOAT BALL</i>
For Model 20-55-NM-P	<i>PLASTIC FLOAT BALL</i>

### 1.2.1 Probe Specifications

**Operating Voltage:** (From Control Units Model 20-35-NM-F / Model 20-35-NM-DIN)

**Current Flow:** Vertical Position 18 mA approx.  
Tilted (Inclination Probe Higher 15°) 8 mA approx.  
Supply Shorted 26 mA approx.  
Failure Supply (Circuit Open) 0 mA

**Temperature Ratings:**  $-40^{\circ}\text{F}(-40^{\circ}\text{C}) \leq T_a \leq +122^{\circ}\text{F}(+50^{\circ}\text{C})$

**Dimensions:** See Figures Chapter 2

**Tilt Angle:**  $> 15^{\circ}$

**Probe Cable Length:** Standard 8m (25 ft); Other lengths on request

## 1.3 Control Unit

### 1.3.1 Model 20-35-NM-F (Field Mount Version)

The Control Unit is housed in an enclosure with green (“normal”) and red (“alarm”) indicating lights on the front cover. An adjustable selection of 1, 2, 4, or 6 seconds of time delay in the control unit circuit will prevent false or premature contact transfer caused by momentary tilting of probe.

Tilt Probe alarm position: Two SPDT output contacts for connection to external alarms and/or controls.

Probe failure or supply short: One normally open (NO) contact.

#### **SPECIFICATIONS:**

##### **Power Requirements**

Voltage: 115/230 VAC +/- 10%, by selector switch

Frequency: 50/60Hz

Consumption: 7VA

Fusing: (F1) 0.05A SB Type T (F2) 0.1A SB Type T

##### **Outputs**

Alarm: Two (2) SPDT contact.

Rated at 10 Amp at 115/230 VAC or 7 Amp at 30 VDC non-inductive

Probe Fault or Supply Short: One (1) NO contact 115/230 VAC 2 Amp, 24VDC 3 Amp.

**Time Delay:** Adjustable 1, 2, 4, or 6 seconds.

**Dimensions:** See Figure 2-1

**Relative Humidity:** Up to 95%, no condensing

**Altitude:** Up to 2000m

**Temperature Rating:**  $-40^{\circ}\text{F}(-40^{\circ}\text{C}) \leq T_a \leq +122^{\circ}\text{F}(+50^{\circ}\text{C})$

**Protection:** NEMA 4, Optional NEMA4X Stainless Steel

### 1.3.2 Model 20-35-NM-DIN (Internal Cabinet Version)

**This Control Unit version must be used ONLY inside an electrical cabinet or a enclosure with degree of protection IP 65 min.**

The Control Unit is housed in an enclosure with the following indicating lights on the front cover:

- led (red) OFF for Probe Tilted
- led (red) ON for Probe Alarm (Failure or Probe supply short)

An adjustable selection of 1, 2, 4, or 6 seconds of time delay circuit in the control unit prevents momentary tilting of probe from causing a false or premature contact transfer.

Tilt Probe alarm position: One normally open (NO) contact.

Probe failure or supply short: One normally open (NO) contact.

#### **SPECIFICATIONS:**

##### **Power Requirements**

Voltage: 115/230 VAC +/- 10%

Frequency: 50/60Hz

Consumption: 3,3VA

Fusing: (F1) 0.05A SB Type T (F2) 0.1A SB Type T

##### **Outputs**

Probe Tilted: One (1) NO contact 115/230 VAC 2 Amp, 24VDC 3 Amp.

Probe Alarm (Fault or Supply Short) : One (1) NO contact 115/230 VAC 2 Amp, 24VDC 3 Amp.

**Time Delay:** Adjustable 1, 2, 4, or 6 seconds.

#### **ENCLOSURE**

**Dimensions:** See Figure 2-2

**Protection:** IP20





**Temperature Rating:**  $-40^{\circ}\text{F}(-40^{\circ}\text{C}) \leq T_a \leq +122^{\circ}\text{F}(+50^{\circ}\text{C})$

**Material Self-Extinguishing:** UL94 – V0

## 1.4 Symbol Identification

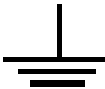
Table 1-1 describes the symbols used in this manual.

**Table 1-1: Symbol Identification**

Symbol	Description
	ALTERNATING CURRENT
	EARTH (GROUND) TERMINAL
	PROTECTIVE CONDUCTOR TERMINAL
	CAUTION, RISK OF ELECTRIC SHOCK
	CAUTION (REFER TO ACCOMPANYING DOCUMENTS)



# Chapter 2 Installation

This chapter contains information regarding the installation of the *Ramsey Mercury Free Tilt Sensor* system.

## 2.1 Control Unit Installation

### Model 20-35-NM-F & 20-35-NM-F-4X

1. The Control Unit should be mounted in a vibration-free area where the ambient temperature does not fall below  $-40^{\circ}\text{C}$  ( $-40^{\circ}\text{F}$ ) or exceed  $50^{\circ}\text{C}$  ( $122^{\circ}\text{F}$ ).
2. The unit enclosure will accept two holes in the bottom for input of  $3/4''$  diameter conduits/cable gland.
3. Use two separate conduits/cable glands, one for the probe and one for the control and/or power circuits.
4. The terminals will accept a 12 AWG stranded wire (maximum)
5. For electrical connections, refer to Figure 2-7.

**Figure 2-1: Control Unit Model 20-35-NM-F & 20-35-NM-F-4X Dimensions**

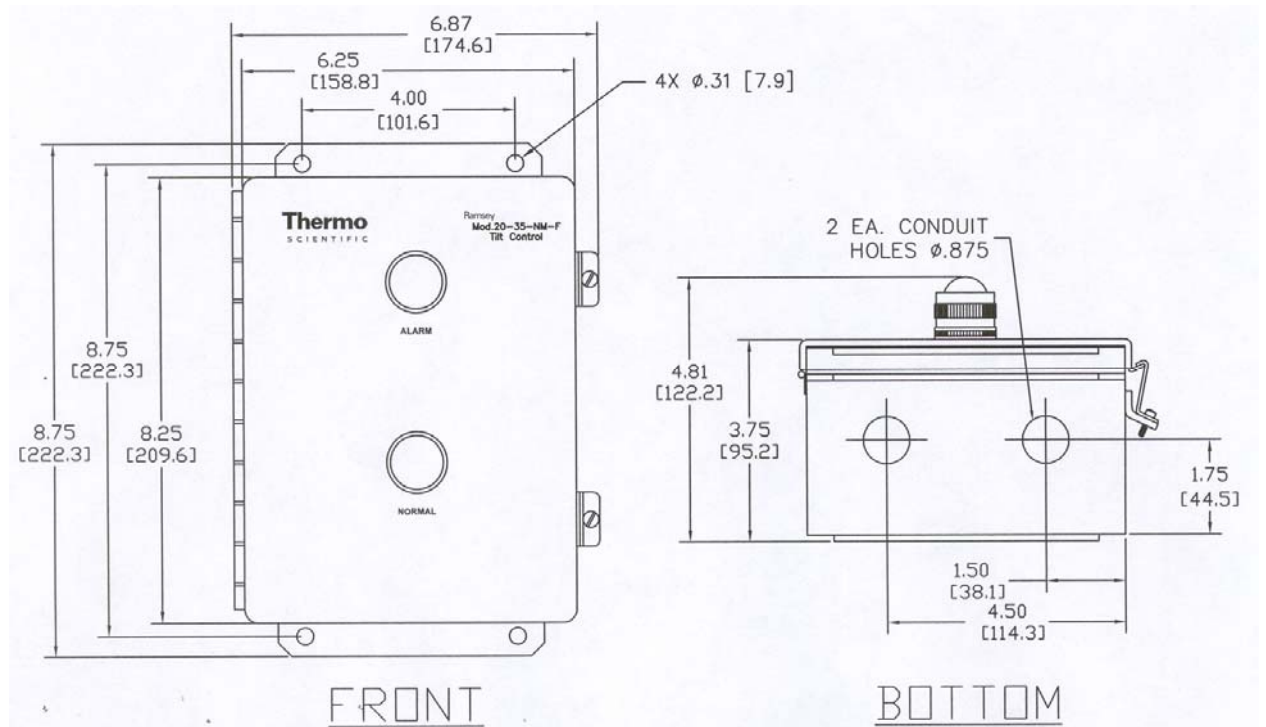

### Model 20-35-NM-DIN

This model is suitable for installation ONLY inside an enclosure with proper mechanical protection.

1. The Control Unit should be mounted in a vibration, heat and humidity free area where the ambient temperature does not fall below  $-40^{\circ}\text{C}$  ( $-40^{\circ}\text{F}$ ) or exceed  $50^{\circ}\text{C}$  ( $122^{\circ}\text{F}$ ).
2. The unit enclosure is supplied with external terminal blocks for electrical connections.
3. Use two separate conduits, one for the probe and one for the control and/or power circuits.
4. The terminals will accept a 12 AWG stranded wire (maximum)
5. For electrical connections, refer to Figure 2-9.

Figure 2-2: Control Unit Model 20-35-NM-DIN Dimensions

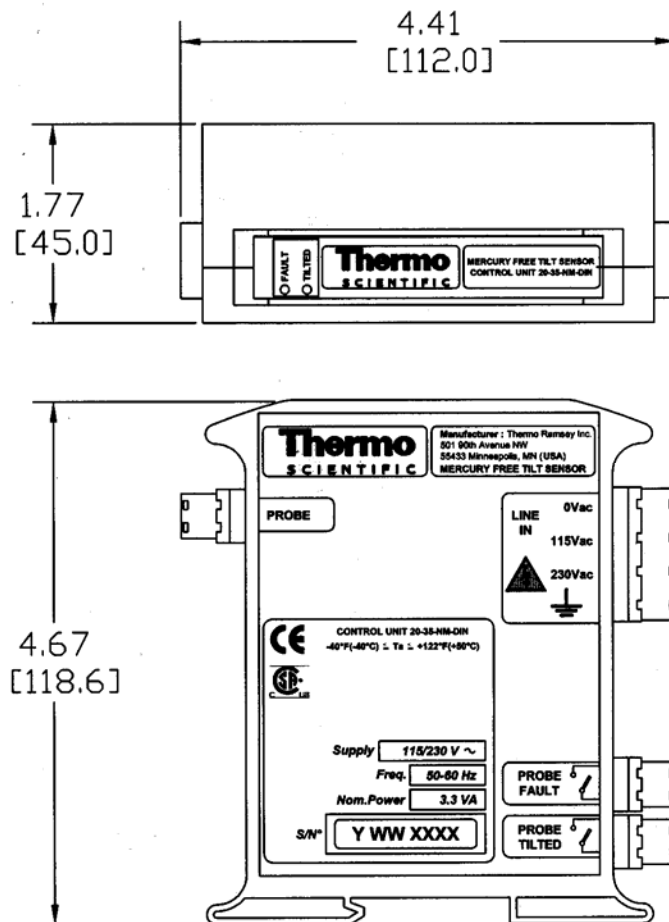

## 2.2 Probe Installation

1. The probe must be installed in a vertical position, suspended at a flexible joint that allows free movements in all directions.
2. Carefully chose the location of the Probe. It is very important to choose the right installation position so the material flow will cause a tilt action and not bury the probe.

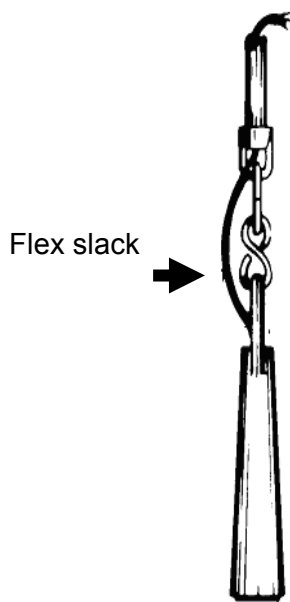

### Normal Installation

When there is no chance of material damaging the flex.

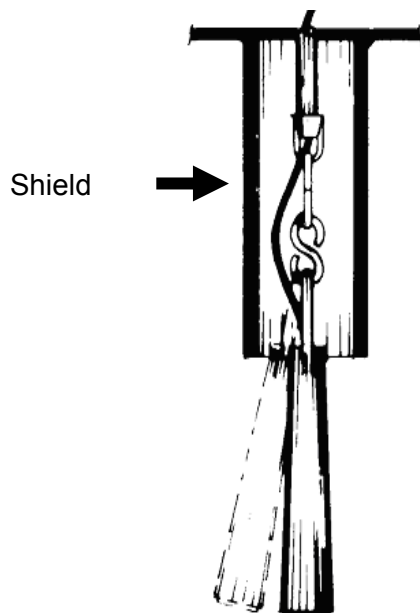

### Shielded Installation

When flex protection is needed and the probe can traverse to alarm position.

Figure 2-3: Probe Model 20-54-NM-SS – Stainless Steel Probe

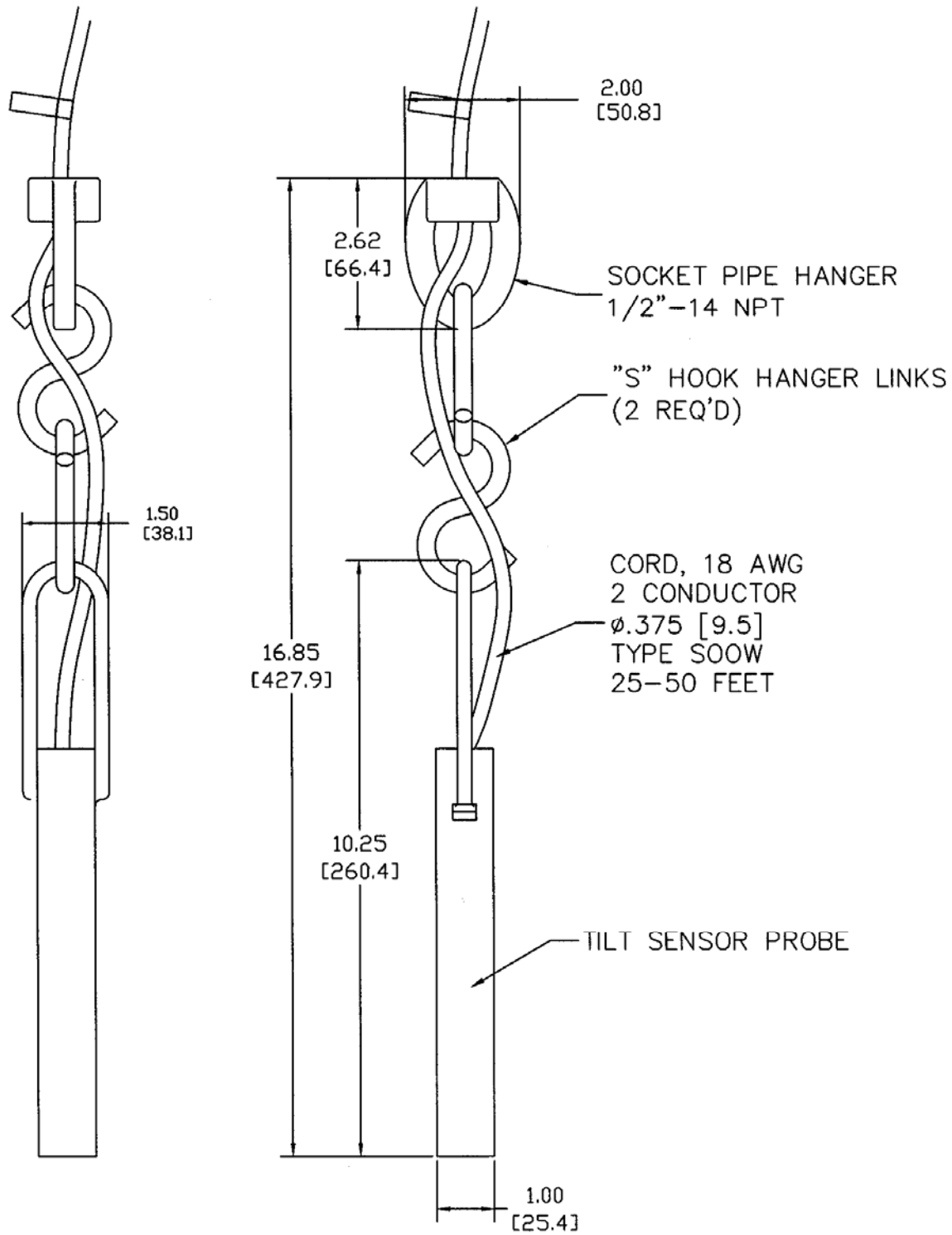

Dimensions are inches and [mm]

Figure 2-4: Probe Model 20-52-NM – Heavy Weight Probe

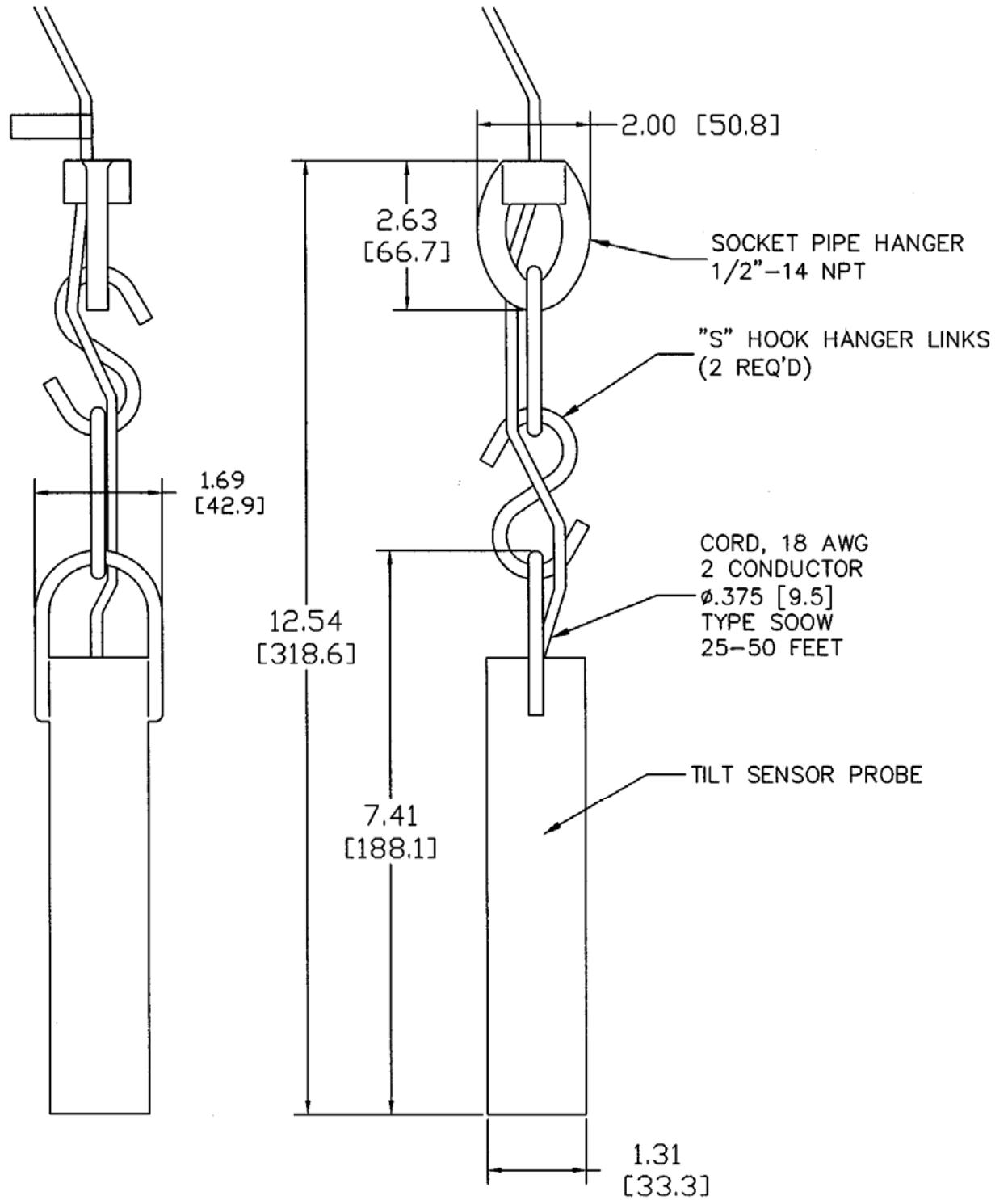

Dimensions are inches and [mm]

Figure 2-5: Probe Model 20-59-NM – Steel Probe

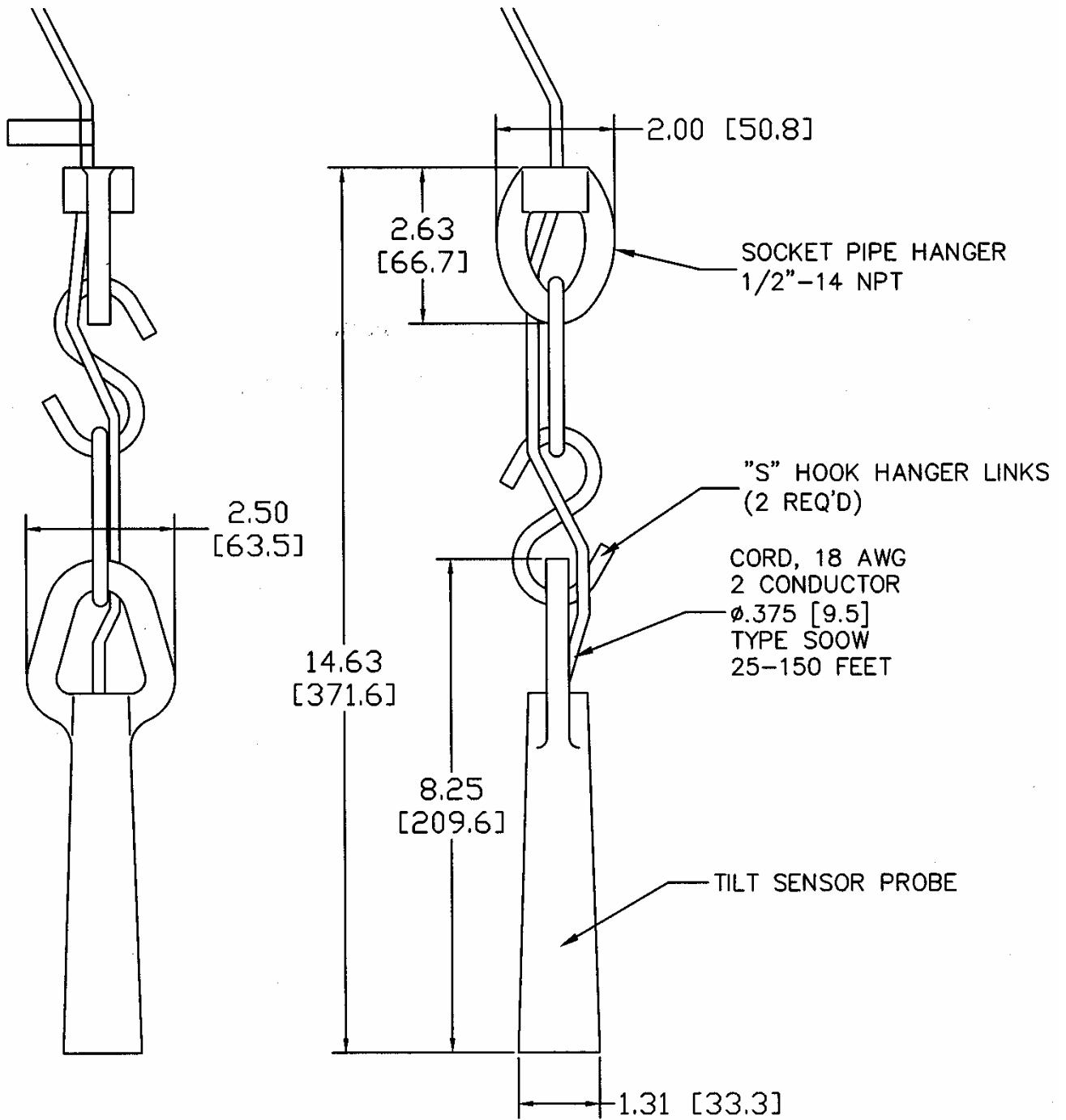

Dimensions are inches and [mm]

**Figure 2-6: Probe Model 20-55-NM-P – Plastic Probe**

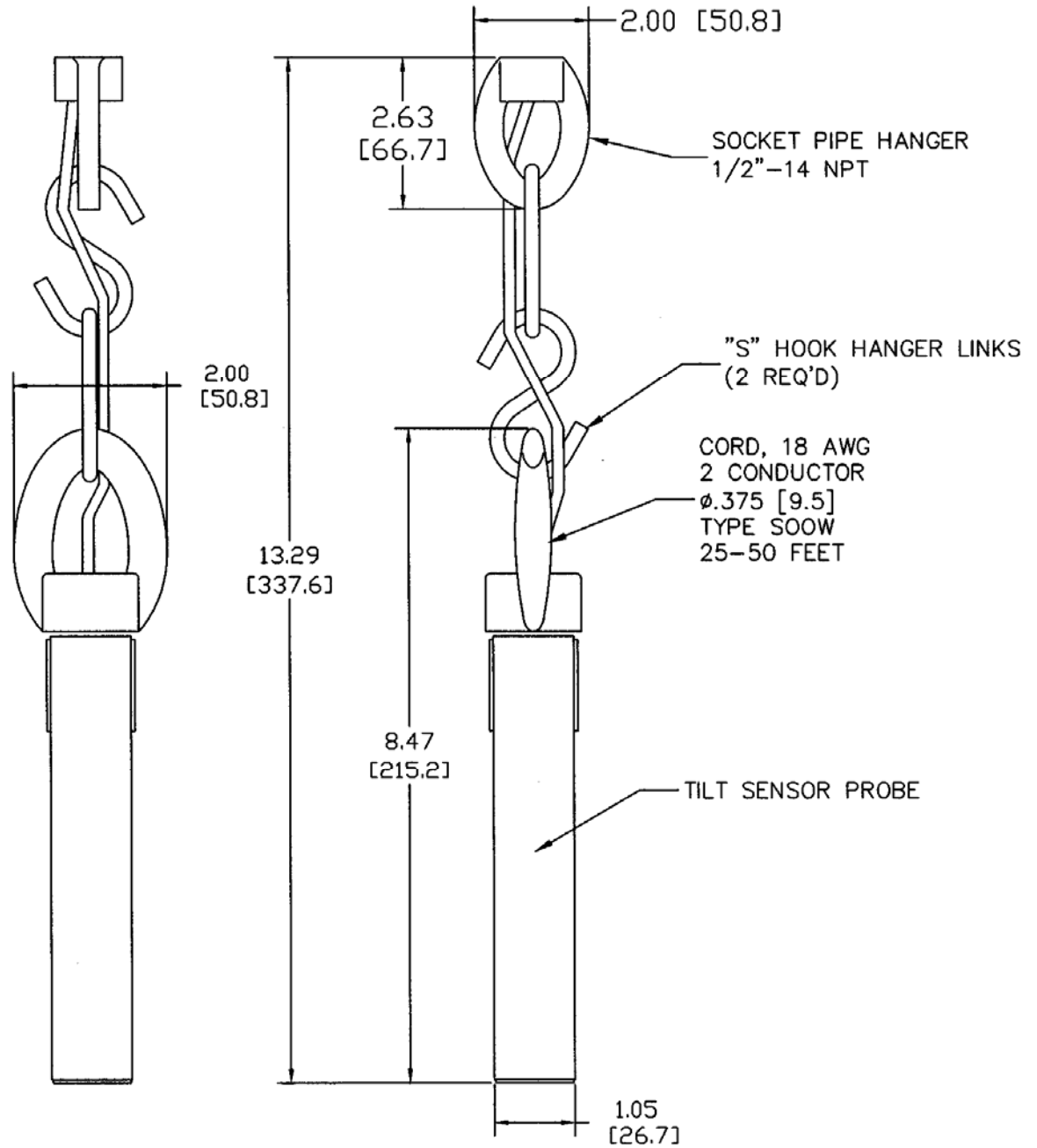

Dimensions are inches and [mm]

## 2.3 Electrical Installation

### CONTROL UNIT Model 20-35-NM-F

- 1 The Control Unit enclosure is supplied with (2) .875 dia. conduit holes in the bottom.
- 2 Use separate conduits/cable glands for probe and power circuits connection.

**Figure 2-7: Control Unit Model 20-35-NM-F Terminal Wiring**

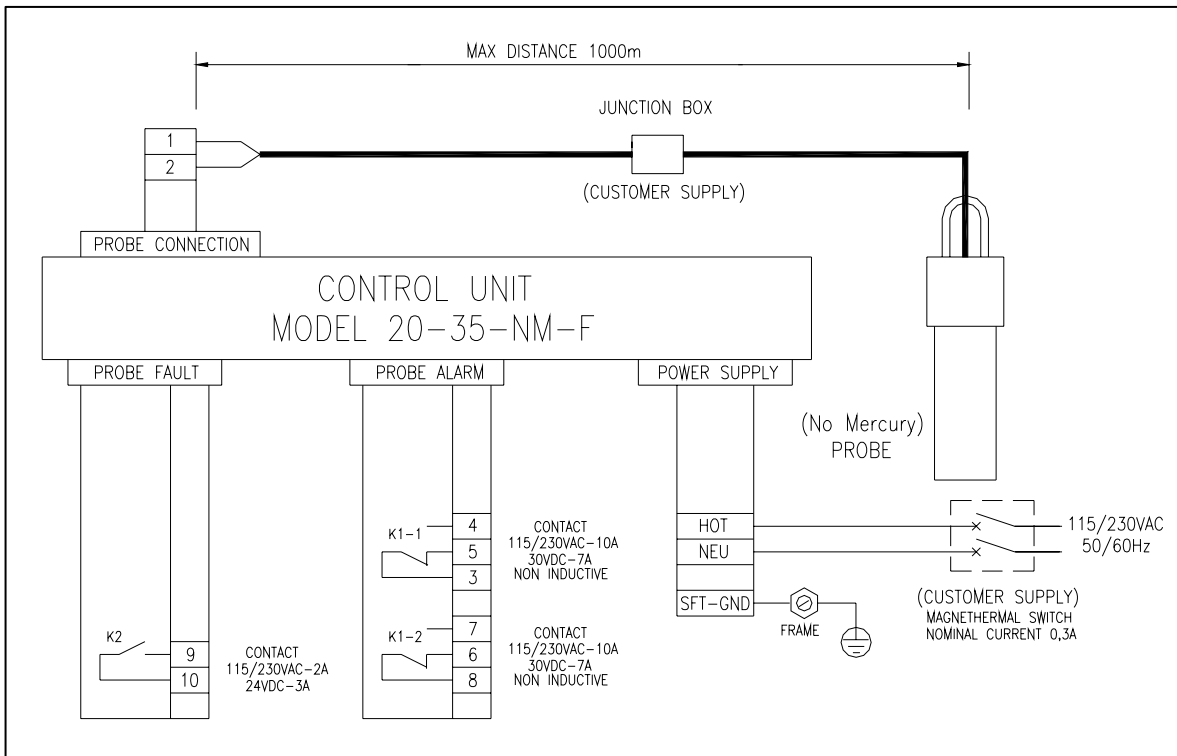

**Figure 2-8: Control Unit Model 20-35-NM-F Internal Layout**

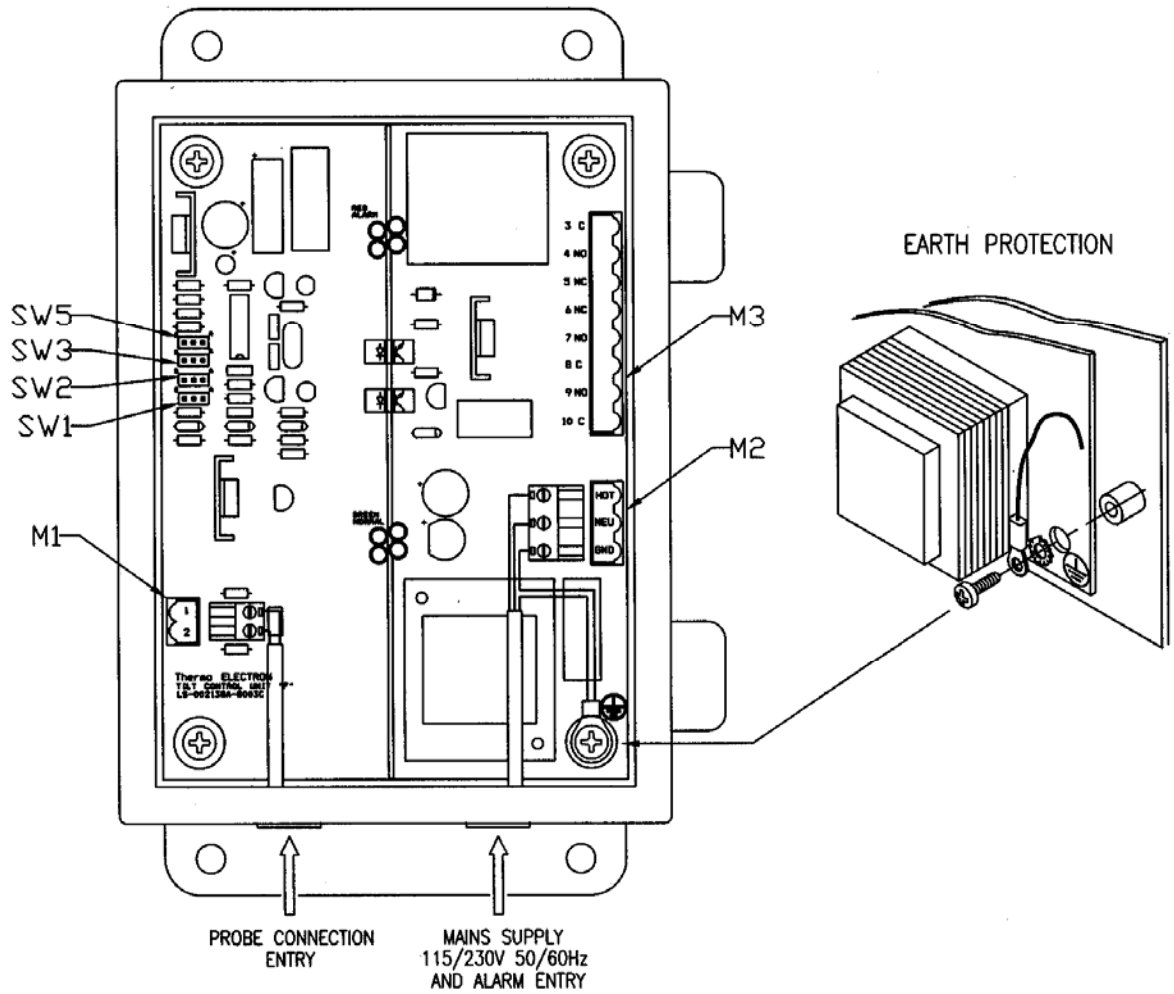

## CONTROL UNIT Model 20-35-NM-DIN

- 1 The Control Unit enclosure is supplied with terminals for connection.
- 2 Use separate conduits/cable glands for probe and power circuits connection.

**Figure 2-9: Control Unit Model 20-35-NM-DIN Terminal Wiring**

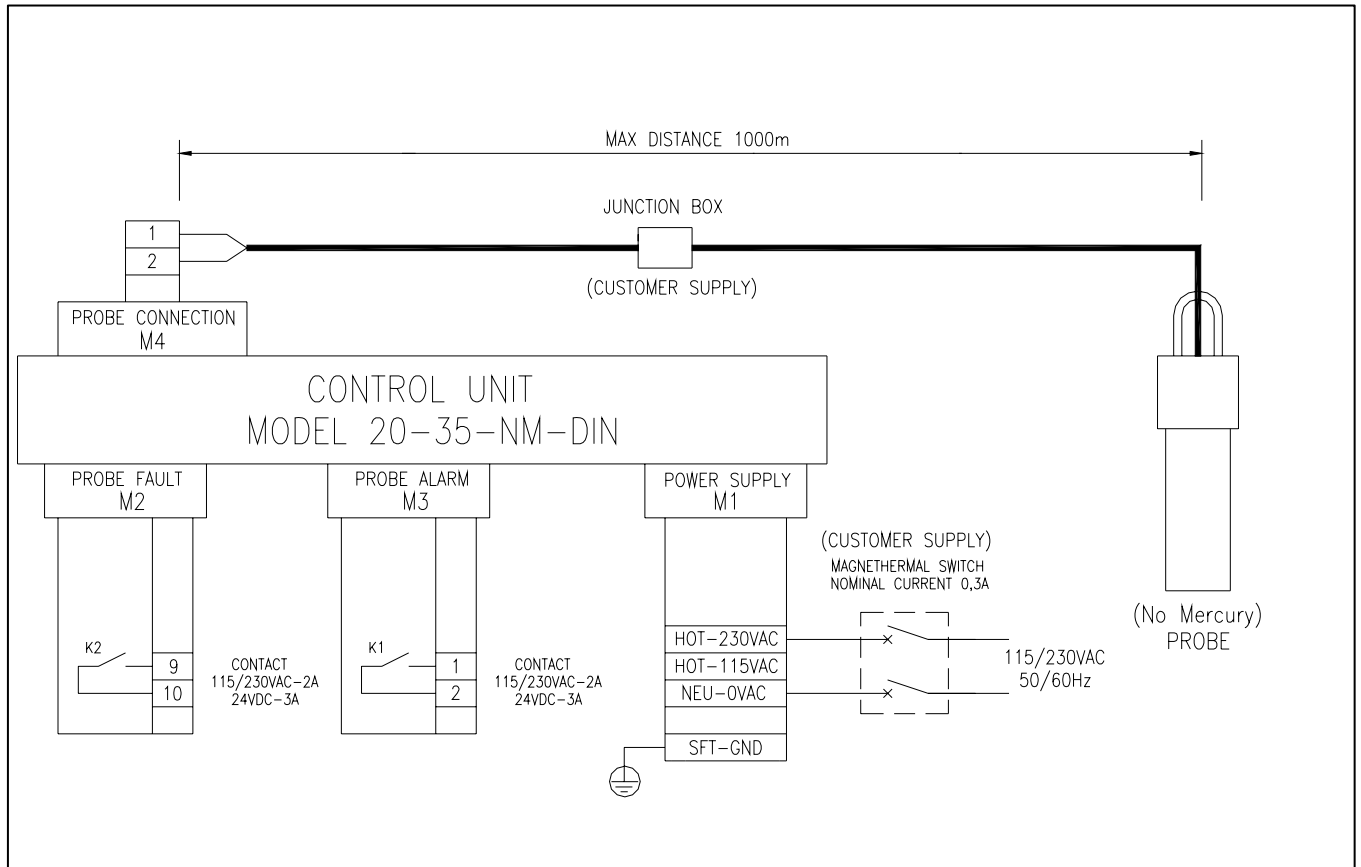
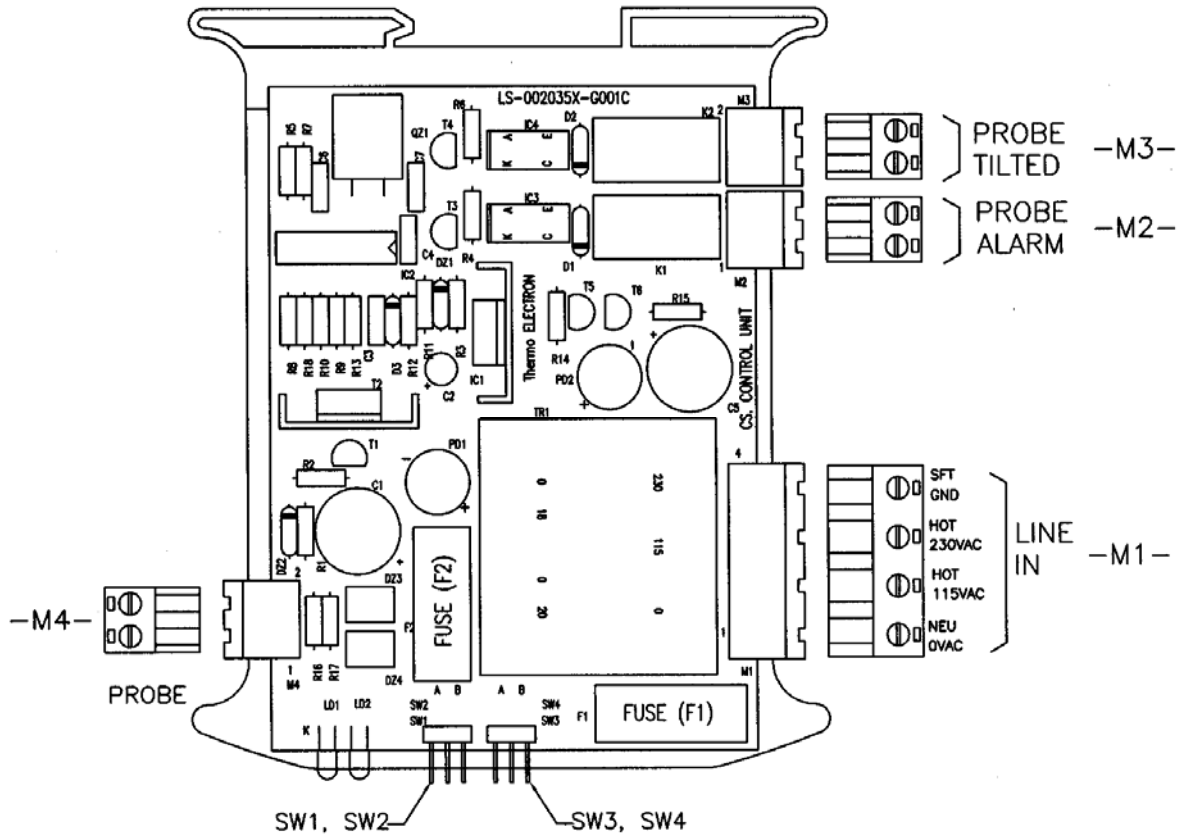

Figure 2-10: Control Unit Model 20-35-NM-DIN Internal Layout





# Chapter 3 Operation

When the *Ramsey Mercury Free Tilt Sensor* system is used as a no-flow detector, the normal position of the probe is tilted. When used as a level detector, the normal position is vertical (not tilted). In both cases the tilted condition indicates the presence of material.

## Flow Application Examples

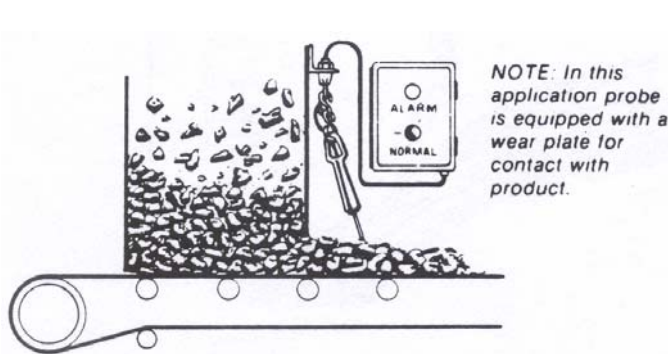

**Material Flow  
"Normal"**

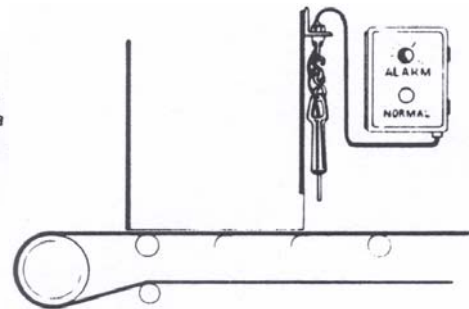

**Material No Flow  
"Alarm"**

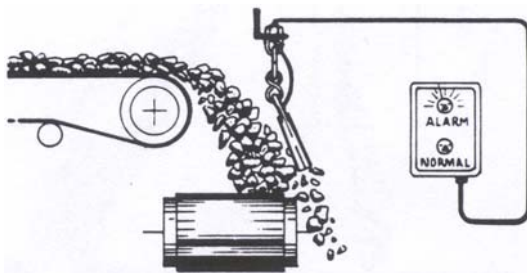

**Material Overshooting  
Transfer Conveyor  
"Alarm"**



**Material Flow "Normal"**

# Low Application Examples

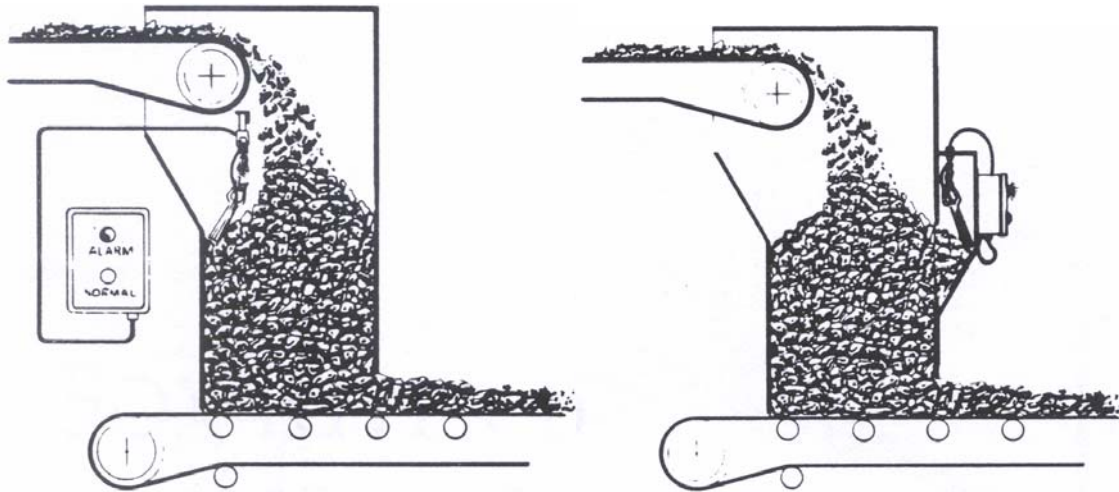
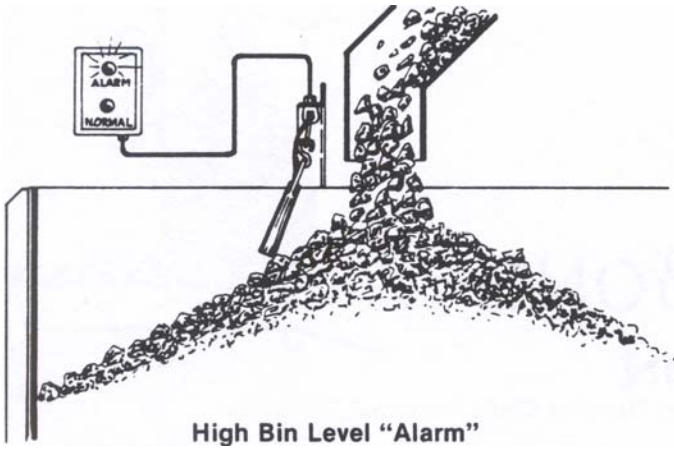

**Typical Plugged Transfer Chute "Alarms"**

## 3.1 System Configuration

Different applications may have different probe positions that indicate a “normal” condition (vertical vs. tilted). There are two jumpers on the circuit board to control the behavior of the alarm lights and contacts in regard to probe position. Use the following Function Mode tables to determine the correct jumper settings for your application.

### 3.1.1 Model 20-35-NM-F Function Modes

**Table 3-1: Model 20-35-NM-F Function Modes Switch Settings**

SW3 (See table 3-3)	SW5 (See table 3-4)	Function Mode	Probe Position	Condition	Lamp Alarm	Delay on Transition to (See table 3-2)
DEFAULT SETTING		Alarm for High Level Detection	Tilted	Alarm	ON	X
Level (B)	High (A)		Vertical	Normal	OFF	
Level (B)	Low (B)	Alarm for Low Level Detection	Tilted	Normal	OFF	
			Vertical	Alarm	ON	X
Flow (A)	Low (B)	Alarm for No Flow Detection	Tilted	Normal	OFF	
			Vertical	Alarm	ON	X
Flow (A)	High (A)	Alarm for Flow Detection	Tilted	Alarm	ON	X
			Vertical	Normal	OFF	

### 3.1.2 Model 20-35-NM-F Switches Setting

SW1 and SW2 Settings are used to delay the indication of alarm conditions. This will prevent alarms due to material momentarily moving the probe.

**Table 3-2: SW1 and SW2 Settings**

SW1	SW2	Delay in Seconds
B	B	1
A	B	2
B	A	4
A	A	6

SW3 determines whether the alarm functions of the control unit respond like a Flow or Level application.

**Table 3-3: SW3 Settings**

SW3	Mode
A	Flow
B	Level

SW5 determines whether the alarm functions of the control unit respond like a High or Low Level application.

**Table 3-4: SW5 Settings**

SW5	Mode
A	High Level
B	Low Level

SW4 defines the instrument electrical power supply

**Table 3-5: SW4 Selector Setting**

SW4	Power Supply
Position	115VAC
Position	230VAC

### 3.1.3 Model 20-35-NM-DIN Function Modes

**Table 3-6: Model 20-35-NM-DIN Function Modes Switch Settings**

SW3 (See table 3-8)	SW4 (See table 3-9)	Function Mode	Probe Position	Condition	Tilted LED	Delay on Transition to (See table 3-7)	Relay K1 Contact
DEFAULT SETTING		Alarm for High Level Detection	Tilted	Alarm	OFF	X	Open
Level (B)	High (A)						
			Vertical	Normal	ON		Closed
Level (B)	Low (B)	Alarm for Low Level Detection	Tilted	Normal	ON		Closed
			Vertical	Alarm	OFF	X	Open
Flow (A)	Low (B)	Alarm for NO Flow Detection	Tilted	Normal	ON		Closed
			Vertical	Alarm	OFF	X	Open
Flow (A)	High (A)	Alarm for Flow Detection	Tilted	Alarm	OFF	X	Open
			Vertical	Normal	ON		Closed

### 3.1.4 Model 20-35-NM-DIN Switches Setting

SW1 and SW2 Settings are used to delay the indication of alarm conditions. This will prevent alarms due to material momentarily moving the probe.

**Table 3-7: SW1 and SW2 Settings**

SW1	SW2	Delay in Seconds
B	B	1
A	B	2
B	A	4
A	A	6

SW3 determines whether the alarm functions of the control unit respond like a Flow or Level application.

**Table 3-8: SW3 Settings**

SW3	Mode
A	Flow
B	Level

SW5 determines whether the alarm functions of the control unit respond like a High or Low Level application.

**Table 3-9: SW4 Settings**

SW4	Mode
A	High Level
B	Low Level

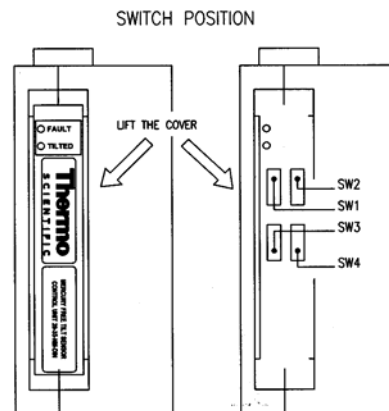

# Chapter 4

## Maintenance and Troubleshooting

### INFORMATION

The manufacturer accepts no liability for any cause, either direct or indirect, of injury to persons and damage to objects resulting from the incorrect, improper, or negligent use of the unit, or from inexperience or negligent running and/or maintenance of the unit itself.

### 4.1 Indication of Maintenance

The *Ramsey Mercury Free Tilt Sensor* system does not require regular maintenance, but it is advisable to perform a periodic functional check, according to the indications below.

It is the exclusive responsibility of the user to determine the frequency of functional checks based on their particular application and installation.

**It is very important to verify that the cable of the Probe is not damaged.**

The *Ramsey Mercury Free Tilt Sensor* system has been designed to operate under normal industrial environments.

The operation of the control unit may be checked by following procedure:



### CAUTION

If the *Ramsey Mercury Free Tilt Sensor* is being used to control other equipment or processes, be sure that appropriate measures are taken so that troubleshooting procedures do not cause any unintended or undesired reactions.

## **4.2 Control Unit Model 20-35-NM-F Check Procedure**

1. Check the power supply voltage. Make sure the AC voltage selector SW4 is set to the proper voltage. The proper voltage must be present between the HOT and NEUT terminals.
2. Check the state of the “Probe Fault” relay K2 and (red) indicator LED 2. If the probe is open-circuited, or the probe cable is shorted, the LED 2 is ON and relay K2 energized.
3. With the probe cable connected, measure the DC voltage across sensor terminals 1 and 2. The measurement should be between 18 and 23 volts.
4. Remove the probe wires from terminals 1 and 2. The “Probe Fault” relay K2 must be energized and LED 2 is ON should indicate a probe fault has occurred (open-circuited or the cable is shorted).
5. With the probe cable still disconnected, measure the voltage at probe terminals 1 and 2. The measurement should be greater than 20 volts DC.

## **4.3 Control Unit Model 20-35-NM-DIN Check Procedure**

1. Check the power supply connection. Make sure the input power wires are connected to the correct inputs on terminal block M1 and that they match the actual AC power supplied to the unit.
2. Check the state of the “FAULT LED” (red). If the probe is open-circuited or the probe cable is shorted, this led is ON.
3. With the probe cable connected, measure the DC voltage across sensor terminal block M4 (terminals 1 and 2). The measurement should be between 18 and 23 volts.
4. Remove the probe wires from terminal block M4 (terminals 1 and 2). The “FAULT LED” must be ON.
5. With the probe cable still disconnected, measure the voltage at probe terminal block M4 (terminals 1 and 2). The measurement should be greater than 20 volts DC.

# Chapter 5

## Service Repair and Replacement Parts

This chapter provides information about service, repair, and replacement parts for your *Thermo Fisher Scientific* product. It includes the telephone numbers for various departments at *Thermo*, the procedure for ordering replacement parts, a Return Material Authorization Form, and the parts list for the product are also included in this chapter.

The maintenance information in this manual is designed to meet your service needs. If you should encounter a problem that requires technical assistance, you may call *Thermo Fisher Scientific Product Service* at (800) 227-8891.

*Thermo Fisher Scientific* also provides on-site service technicians to assist customers with installation, setup, initial calibration, customer training, maintenance, and repair. Contact the *Thermo Fisher Scientific Field Service* department at the number given below for current rates and scheduling.

*Thermo Fisher Scientific* has repair centers located at the plant in Minneapolis, Minnesota. Products that need system checkout or repair can be returned to the plant with the Return Material Authorization (RMA) Form or the Foreign Customer Repair Authorization form. Contact our Repair and Return department (800) 227-8891 to get an RMA number to use on the form.



**Note:** Have your machine model number and serial number available when you call. ▲

Main Switchboard	(800) 227-8891
FAX	(763) 783-2525
Service	(800) 227-8891
Return Material Authorization & Repair	(800) 227-8891

24 x 7 phone support

Or any local *Thermo Fisher Scientific* office.

## 5.1 Parts Ordering Information

For the fastest service when ordering parts, telephone or FAX the *Thermo Fisher Scientific Parts Department* at the numbers given below. Your regional field service representative can also assist you with parts orders.

The recommended procedure for ordering parts is:

1. Determine the broken or faulty part.
2. Locate the part in the Parts List.
3. Find the part number(s) for the item(s) you need.
4. Before you contact *Thermo Fisher Scientific* for your parts, make sure you have the following information:
  - Machine model and serial number
  - Purchase Order number
  - Date Required
  - Preferred shipping method
  - Part number(s), description, and quantity needed.
  - Telephone or FAX:

*Thermo Fisher Scientific*

Customer Service Department

501 90<sup>th</sup> Ave. NW

Minneapolis, MN 55433

FAX: (763) 780-2525

Phone: (800) 227-8891

Return Material Authorization and Repair: (800) 227-8891

# Chapter 6

## Decommissioning and Dismantling

### 6.1 Decommissioning of the System

If the System has to be stopped for a fairly long period of time, then you are advised to take the following precautions:

- Disconnect the product from the circuit
- Move the product “out of production”, clean all parts of it with compressed air in order to remove all dust and other foreign bodies
- Cover the unit and protect it from dust during storage
- Make sure the ambient temperature in the place where the unit is to be stored conforms to the specifications in the technical data table

### 6.2 Dismantling the Unit

To dismantle the System, follow the steps outlined below:

- Disconnect the unit from the circuit
- The resulting waste materials must be disposed of in accordance with the binding legislation in the unit’s country of installation
- Proceed with the disposal in accordance with the binding legislation in the unit’s county of installation



#### **CAUTION**

**Strictly observe all worker safety precautions in all stages of the disassembly.**

# Chapter 7 Labels

This chapter describes the labels reporting the approvals of all *Mercury Free Tilt Sensor* systems. The following figures show where the labels are positioned on the instruments.

## 7.1 Control Unit Model 20-35-NM-F Labels

The following figure shows where the labels are positioned on the instrument.

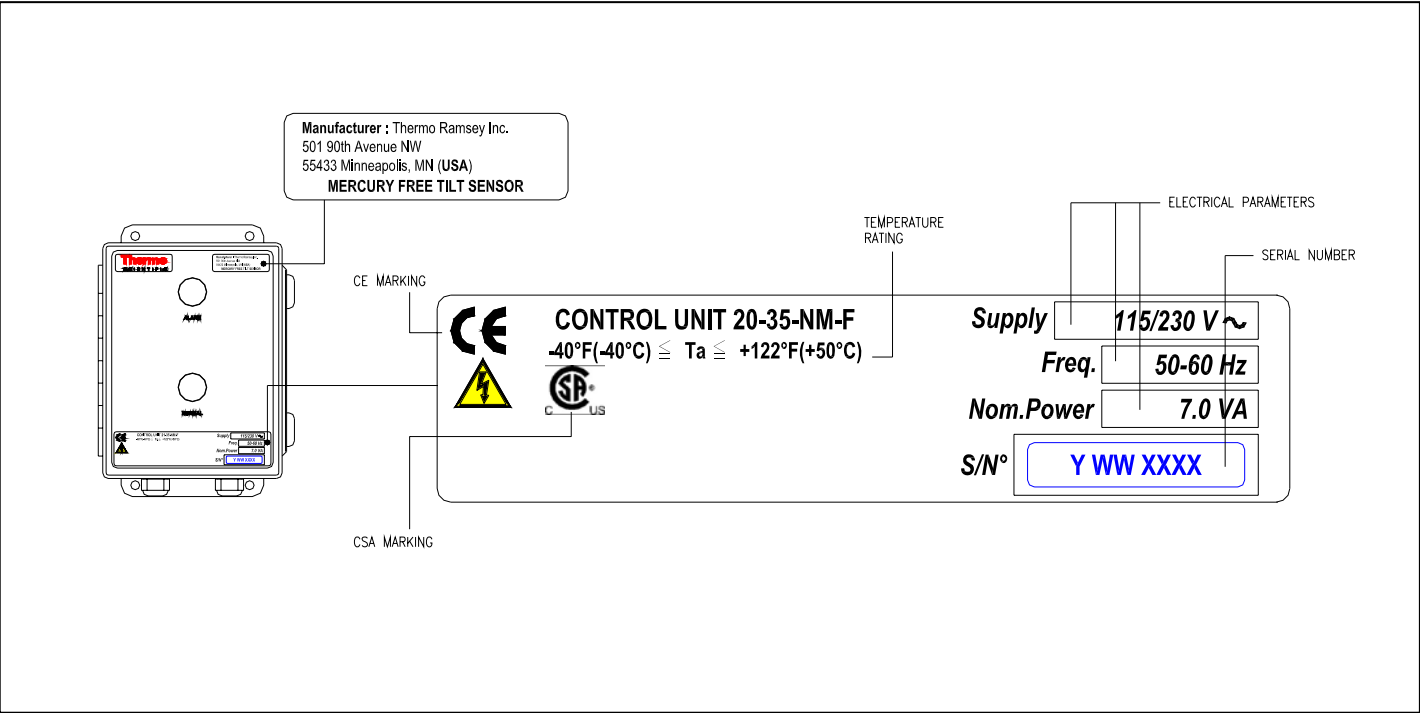

## 7.2 Control Unit Model 20-35-NM-DIN Labels

The following figure shows where the labels are positioned on the instrument.

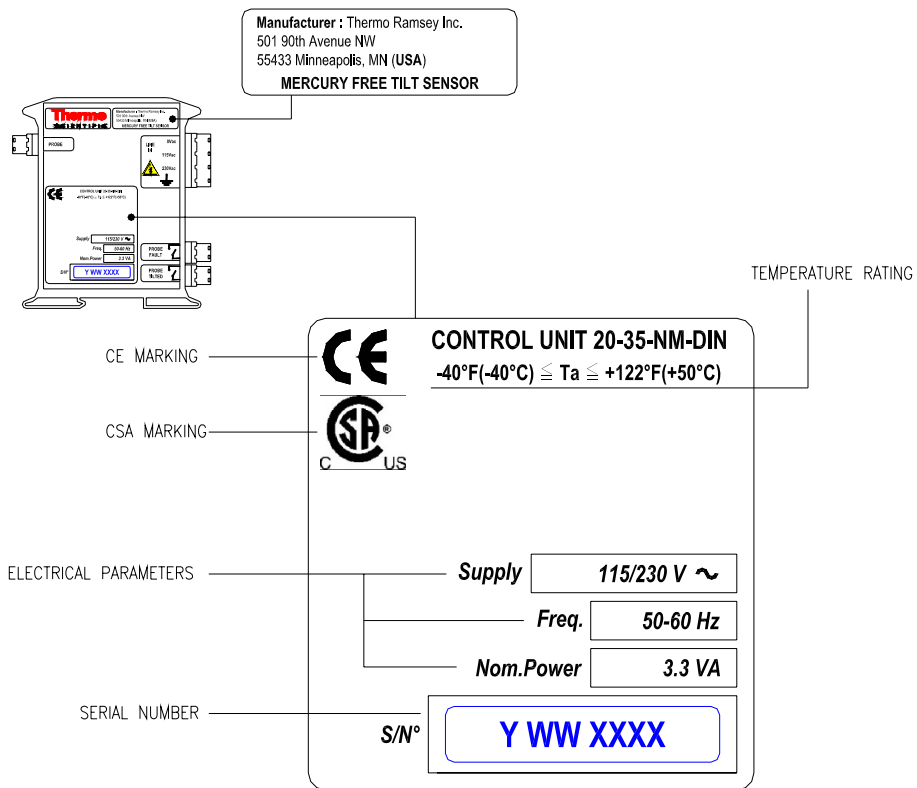

### 7.3 Probe Label

The following figure shows where the labels are positioned on the Tilt Sensor Probes.

