

Tilt Switches and Control Units

Model 21-38 Control Unit
Model 21-39 Heavy Duty
Standard Probe

REC 2294 (FM/CSA) Rev K
Part # 005794

Revision History

Revision Number	Date Released	ECO Number	Release Specifics
Revision J	October 2003		Update Manual Graphics Updated
Revision K	October 2005	0700	Update Manual

©2004 Thermo Electron Corporation. All rights reserved.

This document is confidential and is the property of Thermo Electron Corporation (Thermo). It may not be copied or reproduced in any way without the express written consent of Thermo. This document also is an unpublished work of Thermo. Thermo intends to, and is maintaining the work as confidential information. Thermo also may seek to protect this work as an unpublished copyright. In the event of either inadvertent or deliberate publication, Thermo intends to enforce its rights to this work under the copyright laws as a published work. Those having access to this work may not copy, use, or disclose the information in this work unless expressly authorized by Thermo.

“*Microsoft*” and “*Windows*” are either registered trademarks or trademarks of Microsoft Corporation in the United States and/or other countries.

All other trademarks are the property of Thermo Electron Corporation and its subsidiaries.

Software Program Licence Terms

The Software Program is licensed, not sold. Thermo Electron Corporation, grants you a license for the Software Program only in the country where you acquired the Equipment, as defined below. You obtain no rights other than those granted you under this license.

The term “Equipment” means the equipment with which the Software Program is used. The term “Software Program” means the original and all whole or partial copies of the Software Program used in connection with Equipment sold by Thermo Electron Corporation to the user, including modified copies or portions of the Software Program. Thermo retains title to the Software Program, as well as all improvements, modifications and enhancements to the Software Program, whether made by Thermo or any other party. Thermo owns, or has licensed from the owner, copyrights in the Software Program.

You are responsible for the selection of the Equipment.

Following the commissioning of the Equipment, any change made by the user to the Software Program will terminate all warranties with respect to the Equipment and Software Program.

All other trademarks are the property of Thermo Electron Corporation and its subsidiaries.

License

Under this license, you may:

1. Use the Software Program on only one piece of equipment at any one time, unless the license information specifies otherwise;
2. Copy the Software Program for backup or in order to modify it;
3. Modify the Software Program and/or merge it into another Software Program; and
4. Subject to the following limitations, transfer the possession of the Software Program to another party, but only in connection with a transfer of the Equipment.

If you transfer the Software Program, you must transfer a copy of these License Terms, all other documentation and at least one complete, unaltered copy of the Software Program to the other party. Unless you have other copies of the Software Program to be used in connection with other Equipment purchased from Thermo, or one of its divisions, you must, at the same time, either transfer all your other copies of the Software Program to the transferee of the Equipment or destroy them. Your license is then terminated. The other party agrees to these terms and conditions by its first use of the Software Program.

You must reproduce the copyright notices(s) on each copy of the Software Program.

You may not:

1. Use, copy, modify, merge, or transfer copies of the Software Program except as provided in this license;
2. Reverse engineer, decompile, or disassemble the Software Program; or
3. Sub-license, rent, lease, or assign the Software Program.

Limitation of Remedies

Thermos' entire liability under this license is the following:

Thermo will: (a) replace defective media, or (b) make a warranted Software Program operate or (c) replace the Software Program with a functionally equivalent Software Program, as warranted.

For any claim (including breach), in any form, related in any way to this license, Thermo liability will be for the actual value of the Software Program.

Thermo will not be liable for any lost profits, lost savings, any incidental damages, or other economic consequential damages, even if Thermo, or its authorized supplier, has been advised of the possibility of such damages. Thermo will not be liable for any damages claimed by you based on any third party claim.

General

Thermo may terminate your license if you fail to comply with the terms and conditions of this license. In such event, you must destroy all your copies of the Software Program. You are responsible for payment of any taxes, including personal property taxes, resulting from this license.

Occupational Safety and Health Act (OSHA)

The Occupational Safety and Health Act clearly places the burden of compliance on the user of the equipment and the act is generalized to the extent that determination of compliance is a judgment decision on the part of the local inspection. Hence, Thermo will not be responsible for meeting the full requirements of OSHA in respect to the equipment supplied or for any penalty assessed for failure to meet the requirements, in respect to the equipment supplied, of the Occupational Safety and Health Act, as interpreted by an authorized inspector. Thermo will use their best efforts to remedy such violation at a reasonable cost to the buyer.

Thermo Warranty

The seller agrees, represents, and warrants that the equipment delivered hereunder shall be free from defects in material and workmanship. Such warranty shall not apply to accessories, parts, or material purchased by the seller unless they are manufactured pursuant to seller's design, but shall apply to the workmanship incorporated in the installation of such items in the complete equipment. To the extent purchased parts or accessories are covered by the manufacturer's warranty, seller shall extend such warranty to buyer.

Seller's obligation under said warranty is conditioned upon the return of the defective equipment, transportation charges prepaid, to the seller's factory in Minneapolis, Minnesota, and the submission of reasonable proof to seller prior to return of the equipment that the defect is due to a matter embraced within seller's warranty hereunder. Any such defect in material and workmanship shall be presented to seller as soon as such alleged errors or defects are discovered by purchaser and seller is given opportunity to investigate and correct alleged errors or defects and in all cases, buyer must have notified seller thereof within one (1) year after delivery, or one (1) year after installation if the installation was accomplished by the seller.

Said warranty shall not apply if the equipment shall not have been operated and maintained in accordance with seller's written instructions applicable to such equipment, or if such equipment shall have been repaired or altered or modified without seller's approval; provided, however, that the foregoing limitation of warranty insofar as it relates to repairs, alterations, or modifications, shall not be applicable to routine preventive and corrective maintenance which normally occur in the operation of the equipment.

“EXCEPT FOR THOSE WARRANTIES SPECIFICALLY CONTAINED HEREIN, SELLER DISCLAIMS ANY AND ALL WARRANTIES WITH RESPECT TO THE EQUIPMENT DELIVERED HEREUNDER, INCLUDING THE IMPLIED WARRANTIES OF MERCHANTABILITY AND FITNESS FOR USE. THE SOLE LIABILITY OF SELLER ARISING OUT OF THE WARRANTY CONTAINED HEREIN SHALL BE EXCLUSIVELY LIMITED TO BREACH OF THOSE WARRANTIES. THE SOLE AND EXCLUSIVE REMEDY FOR BREACH OF THE WARRANTIES SET OUT ABOVE SHALL BE LIMITED TO THE REPAIR OR REPLACEMENT OF ANY DEFECTIVE ACCESSORY, PART OR MATERIAL WITH A SIMILAR ITEM FREE FROM DEFECT, AND THE CORRECTION OF ANY DEFECT IN WORKMANSHIP. IN NO EVENT SHALL SELLER BE LIABLE FOR ANY INCIDENTAL OR CONSEQUENTIAL DAMAGES.”

Purchaser agrees to underwrite the cost of any labor required for replacement; including time, travel, and living expenses of a Thermo Field Service Engineer at the closest factory base.

Thermo Electron Corporation
501 90th Ave. NW
Minneapolis, MN 55433
Phone: (800) 227-8891
Fax: (763) 783-2525

Disclaimer

Though the information provided herein is believed to be accurate, be advised that the information contained herein is not a guarantee for satisfactory results. Specifically, this information is neither a warranty nor guarantee, expressed or implied, regarding performance, merchantability, fitness, or any other matter with respect to the products, and recommendation for use of the product/process information in conflict with any patent. Please note that Thermo reserves the right to change and/or improve the product design and specifications without notice.

Factory Mutual Research/Canadian Standards Association

The equipment described in this manual has been approved by Factory Mutual Research (FM), Serial Number J.I. 3007189, for use in hazardous areas, as defined by the National Code and Canadian Standards Association International CSA, Certificate 1437653, provided the following requirements are met.

1. For dust ignitionproof, Class II, Divisions 1 and 2, Groups E, F and G. Tilt Switch Probe Model 21-39 used with Tilt Switch Control Model 21-38 and installed per drawing D06640T-0001 or D06640T-002.
2. For intrinsically safe, Class I, Divisions 1 and 2, Groups A, B, C and D. Tilt Switch Probe Model 21-39 used with Tilt Switch Control Model 21-38 and installed per drawing D06640T or D06640T-0004.

3. Probe Input/Output:

Intrinsically safe, Class I, Division 1 and 2, Groups A, B, C & D.

4. Control:

Dust ignition proof, Class II, III, Division 1, Groups E, F & G, Class II, III, Division 2, Groups F & G, T2A@Ta=85, when used with tilt switch probe per drawing D06640T-0001, -0002, -0003 or -0004.

Occupational Safety and Health Act (OSHA)

The *Occupational Safety and Health Act* clearly places the burden of compliance on the user of the equipment and the act is generalized to the extent that determination of compliance is a judgment decision on the part of the local inspection. Hence, *Thermo* will not be responsible for meeting the full requirements of OSHA in respect to the equipment supplied or for any penalty assessed for failure to meet the requirements, in respect to the equipment supplied, of the *Occupational Safety and Health Act*, as interpreted by an authorized inspector. *Thermo* will use their best efforts to remedy such violation at a reasonable cost to the buyer.

This Page Left Intentionally Blank

Contents

	About this Manual.....	xi
	Who Should Use this Guide?	xi
	Organization of this Guide.....	xi
	Documentation Conventions.....	xii
	Safety Messages.....	xii
	General Precautions	xiii
Chapter 1	Introduction Tilt Switch Probe.....	1-1
	Introduction.....	1-1
	Specifications.....	1-1
Chapter 2	Tilt Switch Control	2-1
	Introduction.....	2-1
	Specifications.....	2-1
Chapter 3	Inspection and Installation.....	3-3
	Inspection.....	3-3
	Installation - Tilt Switch Probe.....	3-3
	Installation - Tilt Switch Control	3-5
	Installation - Electrical.....	3-5
Chapter 4	Theory of Operation	4-1
	General.....	4-1
	Circuit Description.....	4-1
	Setup	5-1
Chapter 5	Setup and Adjustment.....	5-1
	Delay Adjustment	5-1
	No Flow Detection.....	5-2
	Level Detection.....	5-2
Chapter 6	Troubleshooting	6-1
	General.....	6-1
	Troubleshooting Procedure.....	6-1
Chapter 7	Maintenance, Spares and Repair.....	7-1
	General.....	7-1
	Recommended Spares.....	7-1
	Repair.....	7-1

Figures

Figure 1–1. Tilt Switch Probe.....	1-2
Figure 2–1. Switch Control (FM).....	2-2
Figure 2–2. Switch Control CSA.....	2-2
Figure 3–1. Tilt Switch Probe Installation Methods.....	3-4
Figure 3–2. Terminal Strip Data.....	3-6
Figure 3–3. Recommended Field Wiring	3-6
Figure 3–4. Probe - Hazardous Area Class II; Control - Non-Hazardous Area	3-7
Figure 3–5. Probe & Control - Hazardous Area Class II	3-8
Figure 3–6. Probe - Hazardous Area Class I; Control - Non-Hazardous Area	3-9
Figure 3–7. Probe - Hazardous Area Class I Control - Hazardous Area Class II.....	3-10
Figure 4–1. Circuit Board Layout.....	4-2
Figure 4–2. Tilt Switch Control Schematic.....	4-3
Figure 7–1. General Applications	7-2

About this Manual

This manual provides installation, operation, troubleshooting, and repair information for the *Pro-Line Tilt Switches and Control Units* from *Thermo Electron*.

Who Should Use this Guide?

The manual is a learning resource and reference for anyone concerned with the installation, operation, or maintenance of the *Tilt Switches and Control Units*.

Organization of this Guide

This Guide is organized into 5 chapters

Chapter 1: *Introduction - Tilt Switch Probe*

Chapter 1: *Introduction - Tilt Switch Control*

Chapter 3: *Inspection and Installation*

Chapter 4: *Theory of Operation*

Chapter 5: *Setup and Adjustment*

Chapter 6: *Troubleshooting*

Chapter 7: *Maintenance, Spares and Repair*

Documentation Conventions

The following conventions are used in this manual to help easily identify certain types of information.

- **Bold** is used the first time a new term is introduced.
- *Italic* is used to for emphasis and terms that have already been introduced.
- Blue is used for references to other sections of the guide and serve as links in documents.
- **SMALL CAPS** are used in the in the names of setup, calibration, menu displays, and variables.
- **BOLD CAPITALS** are used for the names of keys.
- **Note:** Provides information of special importance to the reader. ▲
- **Hint:** This symbol indicates a hint that may be of value but not necessary for operation. ▲



Safety Messages

Instructions in this manual may require special precautions to ensure the safety of the personnel performing the operations.

There are two levels of safety messages: warnings and cautions. The distinction between the two is as follows:



WARNING. Failure to observe could result in death or serious injury. ▲



CAUTION. Failure to observe may cause minor injury or damage the equipment. ▲

General Precautions

Do not install, operate, or perform any maintenance procedures until you have read the safety precautions presented.



WARNING. Failure to follow safe installation and servicing procedures could result in death or serious injury. ▲

- Make sure only personnel trained by a Thermo Electron representative perform installation and maintenance procedures in accordance with the instructions in this manual.
- Allow only qualified electricians trained by a Thermo Electron representative to open and work in the electronics cabinet, and terminal boxes.
- Covers over the electronics and moving parts must always remain in place during normal operation. Remove only for maintenance with the machine's power OFF. Replace all covers before resuming operation.
- During maintenance, a safety tag (not supplied by Thermo) is to be displayed over the ON/OFF switch area instructing others not to operate the unit (ANSI:B157.1)



CAUTION. High voltage that may be present on leads could cause electrical shock. ▲

- The main isolator switch must be OFF when checking input AC electrical connections, removing or inserting any electrical item, or attaching voltmeters to the system.
- Allow a minimum of 5 minutes between turning the mains isolator to the OFF position and opening the cover of the machine.
- Use extreme caution when testing in, or, or around the electronics cabinet, high voltages in excess of 115V or 230 V are present in these areas.



WARNING: High voltage that may be present on leads could cause electrical shock. ▲

- All switches must be OFF when checking input AC electrical connections, removing or inserting printed circuit boards, or attaching voltmeters to the system.
- Use extreme caution when testing in, on, or around the electronics cabinet, PC boards, or modules. There are voltages in excess of 115 V or 230 V in these areas.
- **WARNING.** Do not make changes to this equipment of any kind without prior consultation with Thermo. ▲



Chapter 1

Introduction Tilt Switch Probe

Introduction

The Tilt Switch Probe actuates when it is tilted 15 degrees or more from its vertical position. The Mercury Switch is precisely positioned so that regardless of direction of tilt the normally closed contact will open.

Specifications

(1)	Contact -	Normally closed Mercury Switch
(2)	Contact Rating -	1 Amp at 24 VDC Non-Inductive
(3)	Temperature Ratings	
	Model 21-39	-25° - 180° F
(4)	Housing	Ductile Iron
(5)	Finish	Chrome Plated Nickel
(6)	Dimensions	See Figure 1-1
(7)	Tilt Angle	10° to 25°

Figure 1-1. Tilt Switch Probe

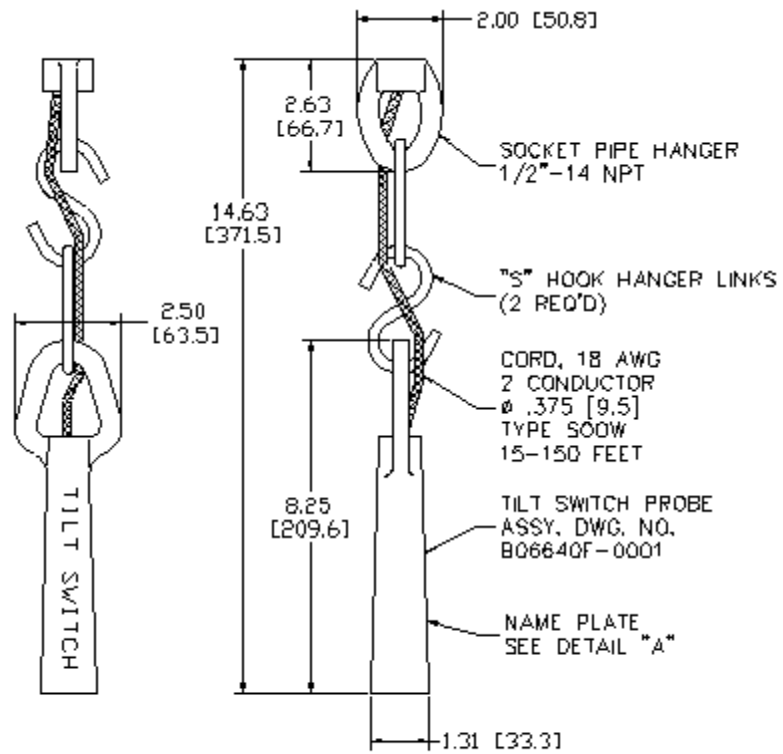

*DIMENSIONS ARE INCHES AND [mm]

Chapter 2

Tilt Switch Control

Introduction

The Control Unit is housed in an enclosure with large green ("Normal") and red ("Alarm") indicating lights on the front cover. A 0-10 second adjustable time delay circuit in the control unit prevents momentary tilting of the switch from causing a false or premature contact transfer. Two normally open and two normally closed output contacts are available for connection to external alarms and/or controls. Interruption of line power causes a relay transfer.

Specifications

- (1) Power Requirements
 - Voltage - 115 VAC \pm 10%
 - Frequency 47 60 62 Hz
 - Consumption 10 Watts
- (2) Outputs
 - One (1) DPDT contact. Rated at 10 Amp at 115 VAC or 7 Amp at 30 VDC non-inductive
- (3) Time Delay
 - Adjustable: 0-10- 23 seconds
- (4) Selectable Jumper
 - Permits normal output condition for either vertical or tilted position of probe
- (5) Classification
 - Probe Input/Output: Intrinsically safe, Class I, Division 1 and 2, Groups A, B, C, and D
 - Control: Dust ignition proof, Class II, III, Division 1, Groups #, F & G, Class II, III, Division 2, Groups F & G, T2A@Ta=85, when used with tilt switch probe per drawing D06640T-0001, -0002, -0003, or -0004
- (6) Dimensions See **Figure 2-1**
- (7) Temperature Rateing -40° to 140° F

Enclosure versions with conduit hubs NEMA 12, 4, and 4X

Figure 2-1. Switch Control (FM)

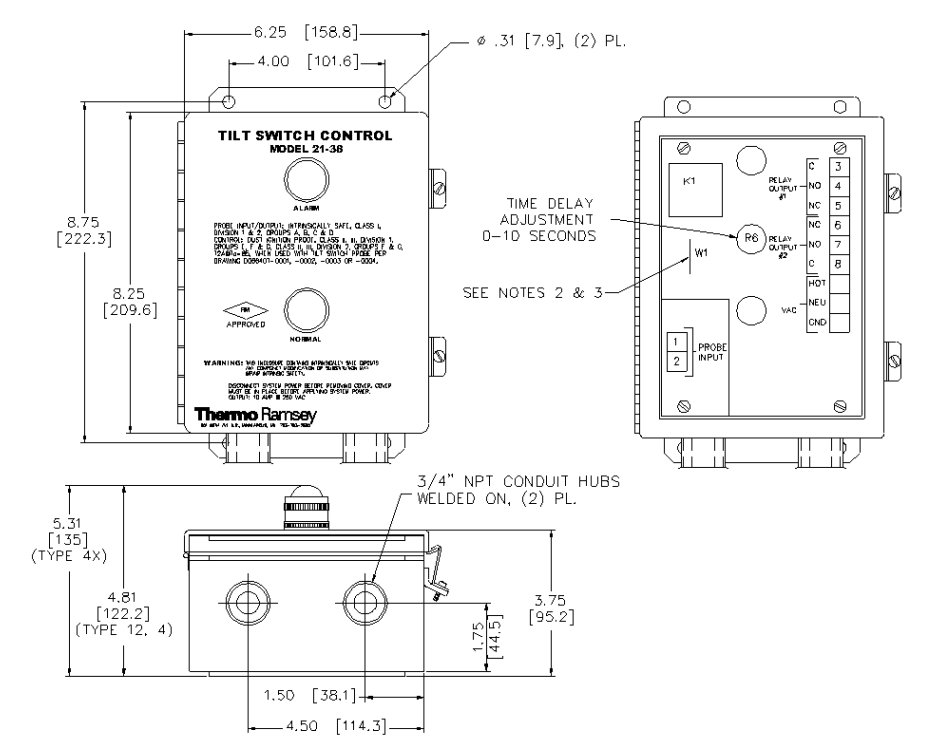
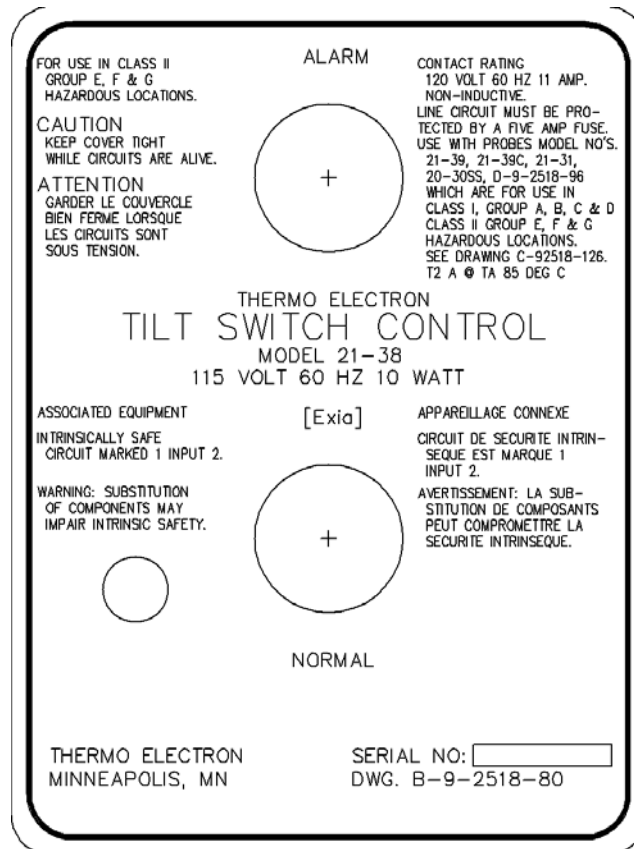

Figure 2-2. Switch Control CSA



Chapter 3

Inspection and Installation

Inspection

Inspect the packages for external damage before opening as often times the carrier can be held responsible for shipping damages. After unpacking, inspect the unit for broken components, etc.

Installation - Tilt Switch Probe

1. Refer to **Figure 1-1** for Dimensional Data
2. Refer to for Installation Methods

Figure 3-1. Tilt Switch Probe Installation Methods

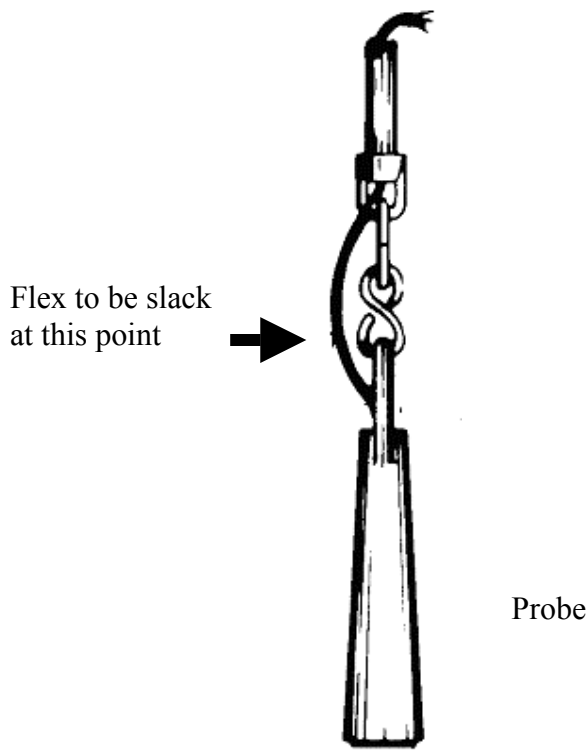

Normal Installation where there is no chance of material damaging or severing flex.

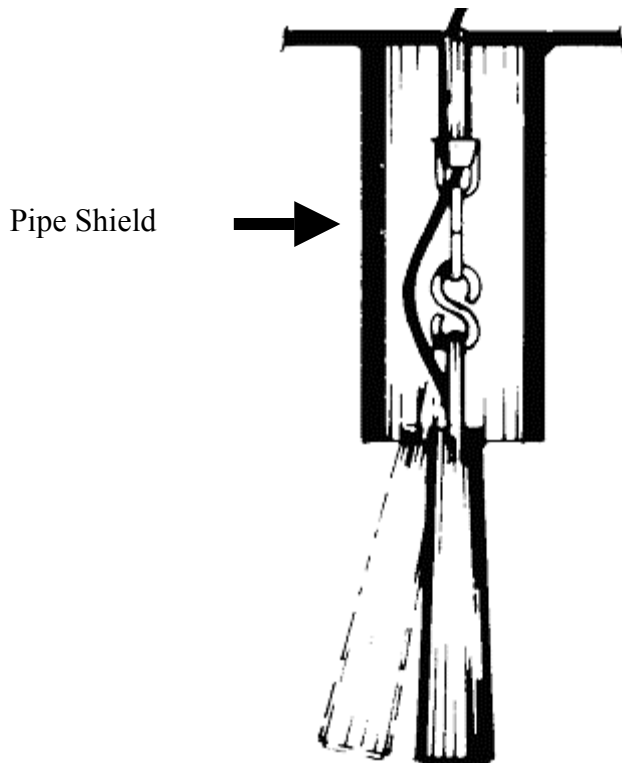

Shielded Installation where a pipe shield is to be such that probe can traverse to alarm position.

Installation - Tilt Switch Control

1. Refer to **Figure 2-1** for Dimensional Data
2. The Control Unit should be mounted in a vibration free area where the ambient temperature does not exceed 120° F.

Installation - Electrical

1. The Control Unit enclosure is supplied with two (2) 3/4"-14-NPT conduit hubs in the bottom.
2. User separate conduit for probe and power circuits.
3. Refer to Figure 3-4.

Figure 3-2. Terminal Strip Data

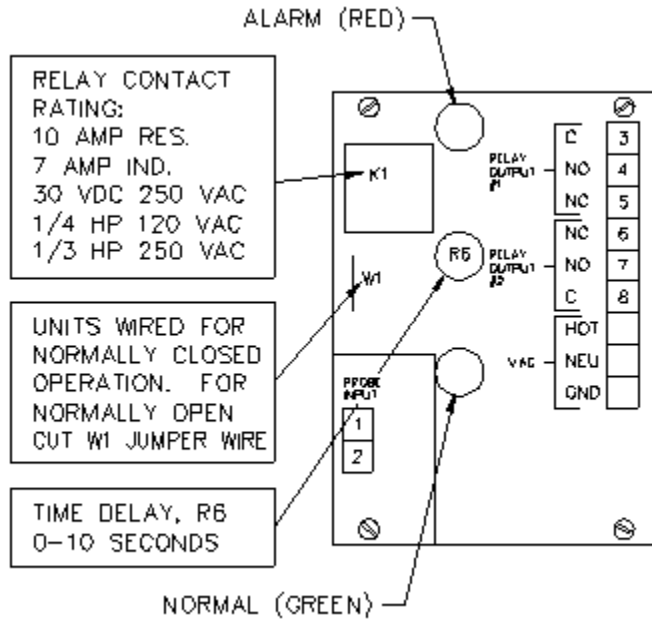
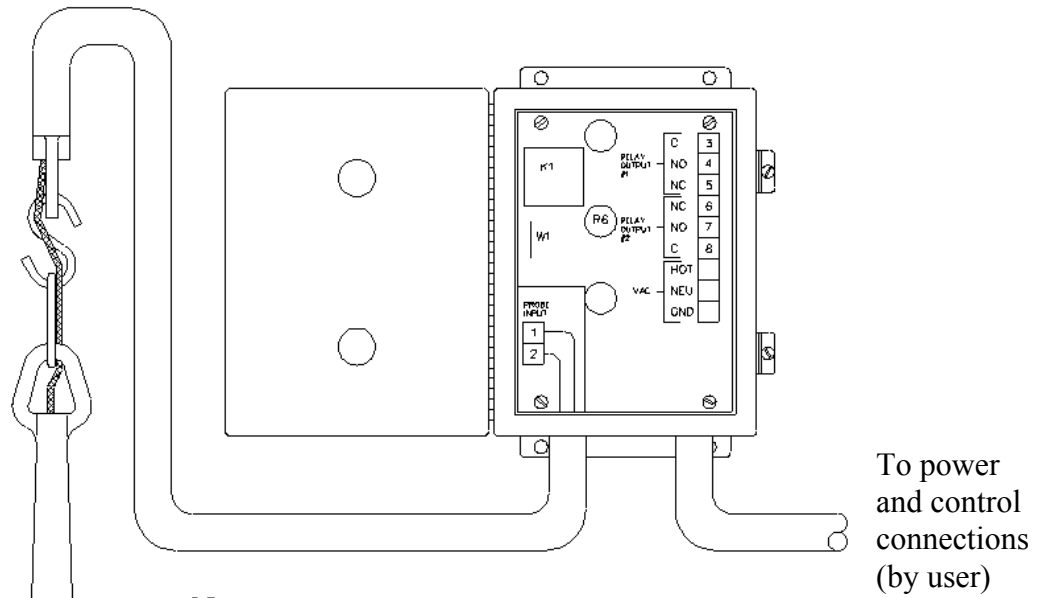

Figure 3-3. Recommended Field Wiring



Notes:

1. All wiring by user
2. Wiring to conform to applicable national electric code specifications for area where assembly is located.

Figure 3-4. Probe - Hazardous Area Class II; Control - Non-Hazardous Area

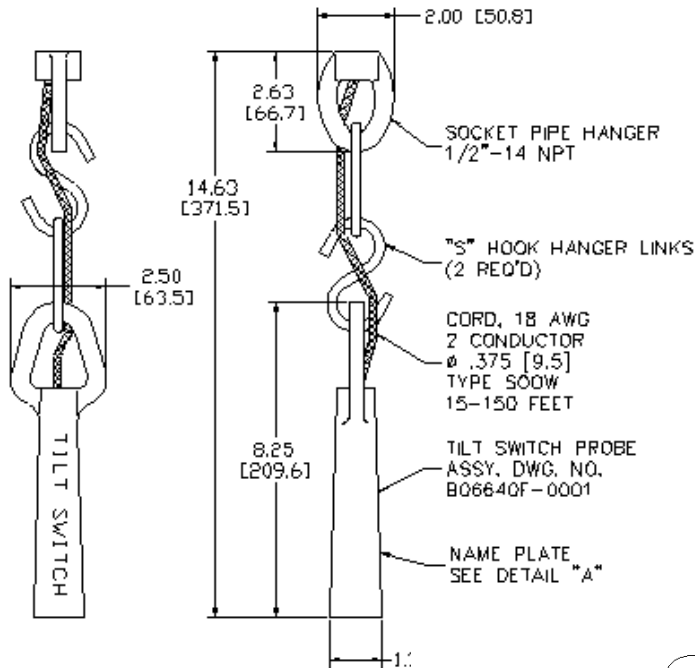

**DIMENSIONS ARE INCHES AND [mm]

HAZARDOUS AREA, CLASS II, III
 DIVISION 1, GROUPS E, F & G
 CLASS II, III, DIVISION 2,
 GROUPS F & G

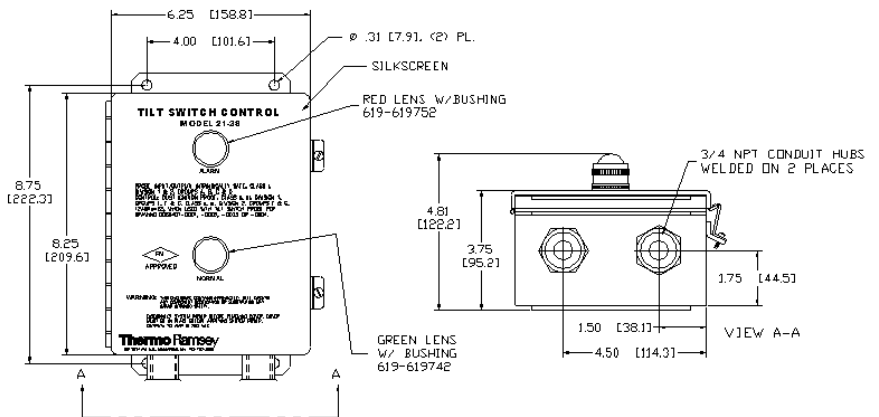
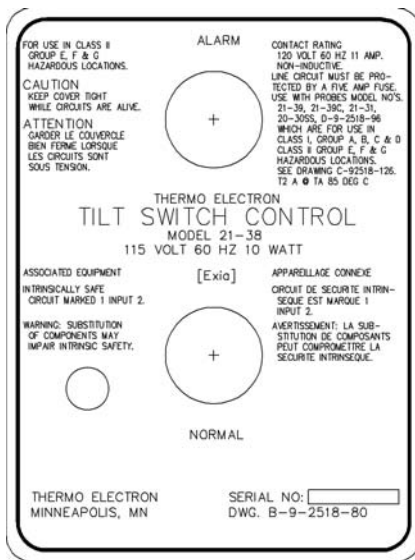
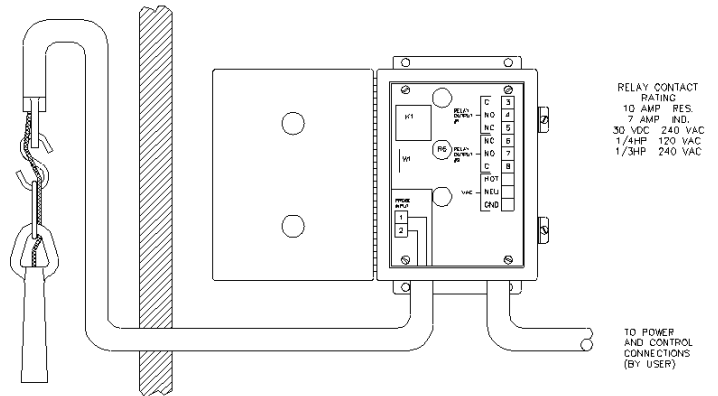
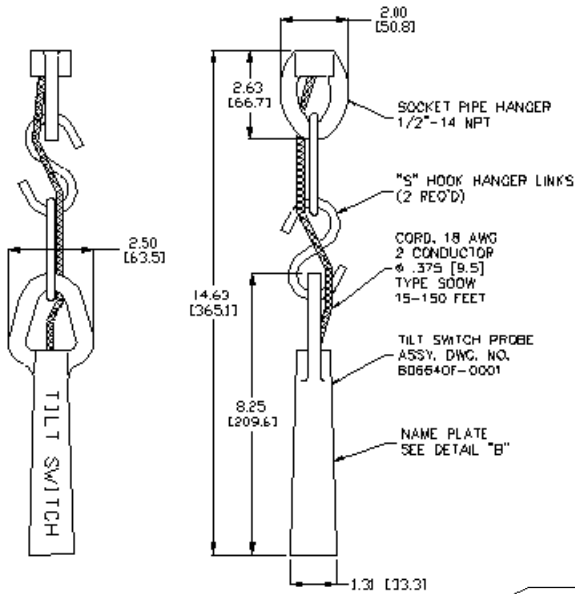

Figure 3-5. Probe & Control - Hazardous Area Class II



**DIMENSIONS ARE INCHES AND [mm]

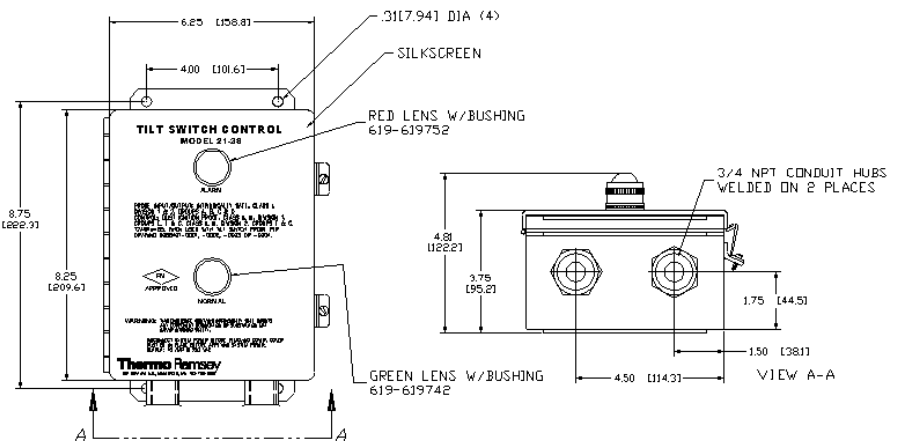
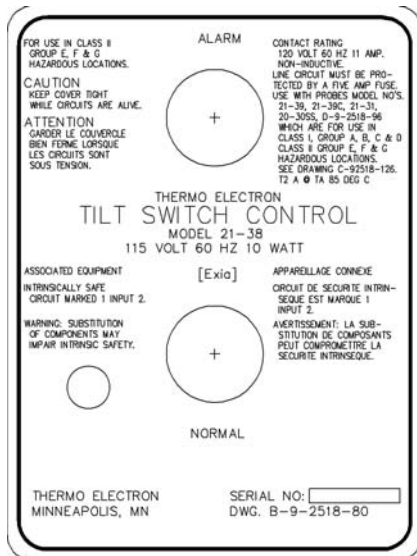
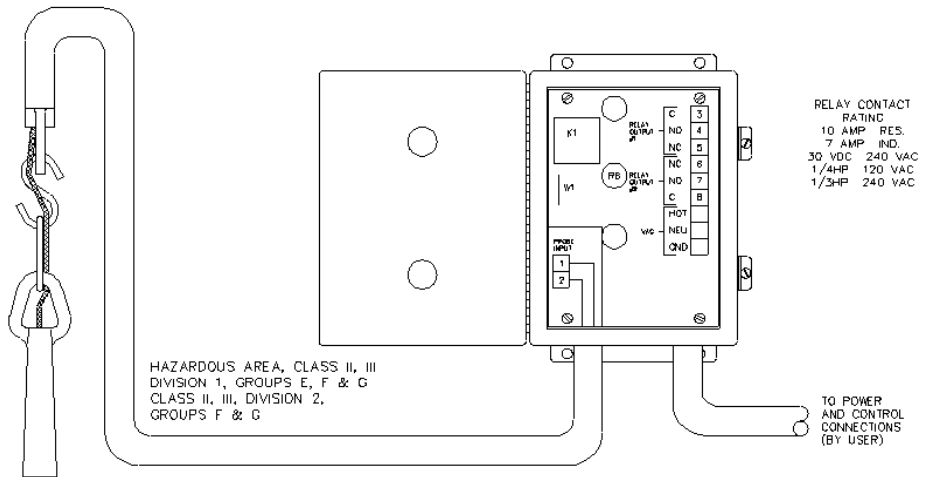
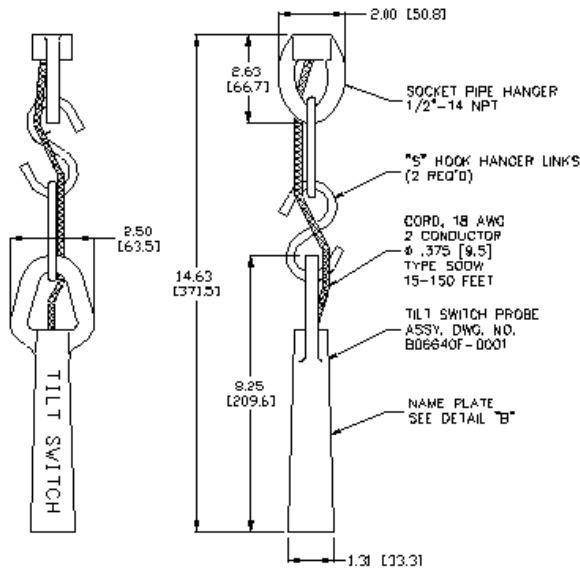
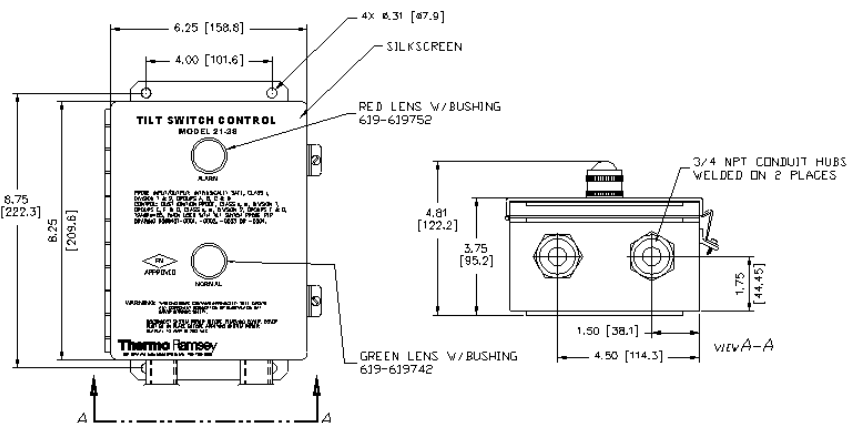
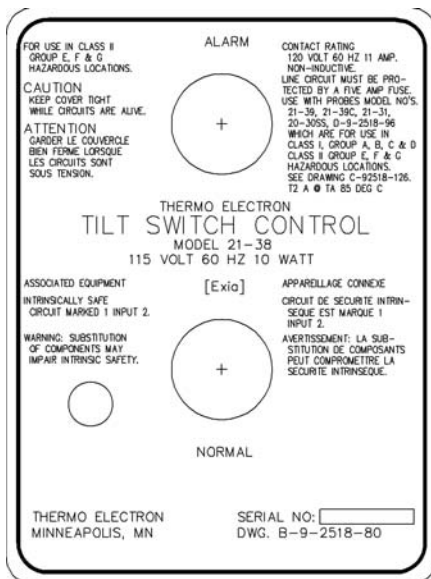
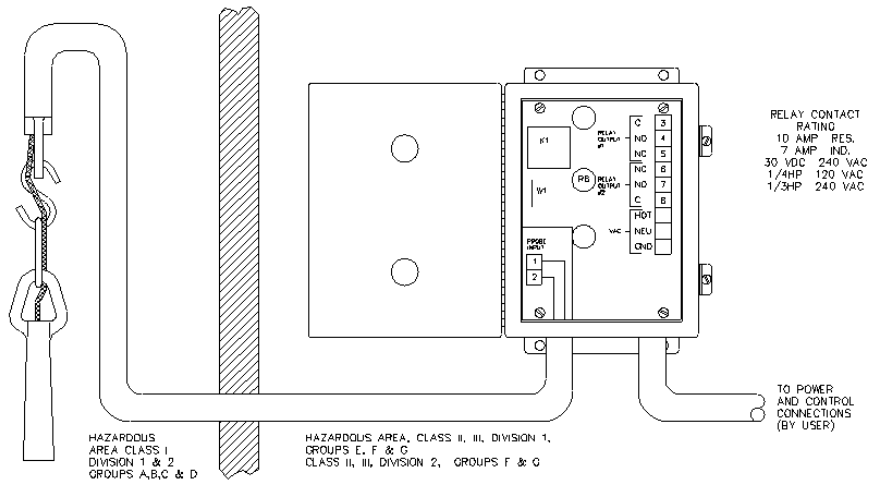

Figure 3-7. Probe - Hazardous Area Class I Control - Hazardous Area Class II



**DIMENSIONS ARE INCHES AND [mm]



Chapter 4

Theory of Operation

General

Refer to **Figure 4–1** and **Figure 4–2** while reading the following circuit description.

Circuit Description

The Tilt Switch Control consists of five Functional circuits. They are (1) DC power supply, (2) Switch Closure Detector, (3) Time Delay Generator, (4) Relay Drive Circuitry, and (5) Power Relay.

The switch closure detector is comprised of the D section of Schmidt Gate U1 and several high value resistors (R8 through R13). With the input (contacts 1 and 2) not shorted, pin 12 of U1D will be at ground potential which causes the output at pin 11 of this NAND gate to be positive. When the inputs, 1 and 2, are shorted together pin 12 of U1D is pulled to -15V causing an abrupt transition of pin 11, the output of U1D, from +15 to ground potential. This voltage change passes through jumper W1 and D5 to discharge C7 rapidly to ground potential causing output pin 3 of U1A to go positive.

The positive going signal at pin 3 of U1A turns on Q1, a low current triac which closes relay K1. In this condition the "normal" pilot light is lit. When input contacts 1 and 2 are not shorted, pin 12 of U1D goes to ground potential, causing pin 11, the output of U1D, to go positive. This positive going signal then must pass through the delay potentiometer, RN1, and charge up capacitor C6. Depending on this potentiometer's setting the time will be from 1 to 10 seconds before pins 1 and 2 of U1A go to positive enough to cause U1A to trigger and pin 3 to go to ground potential turning off triac Q1 and allowing relay K1 to open and the alarm light to come on.

The time delay portion of this circuit also contains section U1C, an inverting gate, which allows the operation of the input switch to be reversed. In normal operation (with W1 installed) the inverted signal from U1C is overridden since it must go through a 33K resistor before reaching diode D5. However, when W1 is removed the inverted signal is then operative and the operation of the circuit is the reverse of that described above.

Figure 4-1. Circuit Board Layout

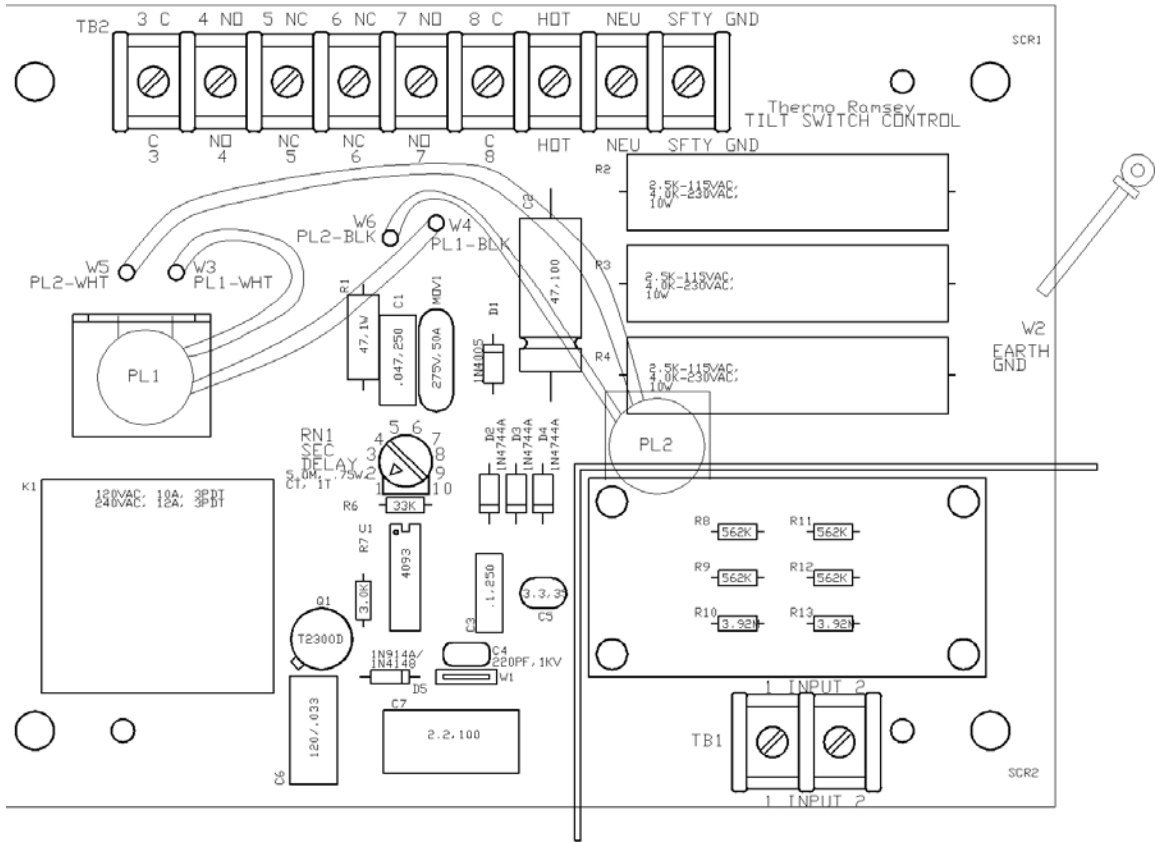

This Page left intentionally Blank.

Chapter 5

Setup and Adjustment

Setup When the Tilt Switch System is used as a no flow detector the normal position of the probe is tilted and when used as a level detector the normal position is vertical (not tilted). Because these uses are opposite each other, one circuit board jumper must be checked before applying power.

Refer to **Figure 4-1** for location of jumper W-1.

Select from operational chart, Figure 5-1, the desired mode of operation and check jumper W-1 for conformance to chart, change jumper if necessary.

Delay Adjustment

This adjustment will prevent relay output contacts from transferring when probe is momentarily or falsely tripped.

The range of adjustment is 0-10 seconds, because the actual delay time is application dependent it must be adjusted at the time of installation.

When setting this adjustment begin at the full CCW pot position and increase until false tripping is a minimum. A typical delay time is 5 seconds

Table 5-1. Operational Chart

Mode	Input	Terminal 1 & 2	Output Indication	Delay Initiated When Input Reverts To:	Relay State	Jumper W-1
	Tilt Switch Position					
No Flow Detector	Tilted	Open	Normal		Energized	Not Installed
	Vertical	Shorted	Alarm	X	De- Energized	
Level Detector	Tilted	Open	Alarm	X	De- Energized	Installed
	Vertical (no tilt)	Shorted	Normal		Energized	

No Flow Detection

- Normal Condition: Switch in “tilt” position
- Alarm Condition: Switch in vertical position

Level Detection

- Normal Condition: Switch in vertical position
- Alarm Condition: Switch in “tilt” position

Chapter 6

Troubleshooting

General The Tilt Switch control system has been designed to operate under normal industrial environments. The majority of failures encountered have been the result of excessive vibration, misapplication of the probe or switching excessive currents or voltages.

The operation of the control unit may be checked by following the procedure.



CAUTION. When following the procedure, remember that if the unit is controlling other equipment, the equipment concerned will either be shut down or started up, depending on the application.

Troubleshooting Procedure

1. Check supply voltage. The proper voltage must be applied to terminals hot and neutral.
2. Disconnect probe wires at terminals 1 and 2.
3. Turn time delay control completely CCW. (Remember where it was set so that it may be returned to the same setting.)
4. Short across terminals 1 and 2. (There are no hazardous voltages at these terminals.) If the unit is operating properly, the following will occur:

The relay will reverse its state. (Careful observation thru the plastic cover of the relay will reveal movement of the armature if it is functioning.)

- The light that was illuminated will be de-energized and the one that was de-energized will be illuminated.
 - Relay operation may also be checked by disconnecting wires at terminals 3, 4, and 5 or 6, 7, and 8, and connecting an ohmmeter at the terminals.
5. Turn the time delay control slightly CW and repeat Step 4. The action as previously observed should be repeated, however, the relay de-energized action will be preceded by the delay period as set.

6. If the unit functions as described, the problem most likely is in the probe, its cable, or field wiring between the probe and the control unit. (This device may be checked with an ohmmeter for proper operation.) If the unit does not function as described, see the Maintenance chapter.

Chapter 7

Maintenance, Spares and Repair

General

Except for the parts replacements mentioned below, Thermo Electron recommends that repairs not be attempted on this unit. Unauthorized repairs during the warranty period will void the warranty.

Recommended Spares

1. One (1) Thermo Electron 21-38-1 115 VAC, Part #069899 or 21-38-1 230 VAC, Part # 069867
2. Two (2) lamps 115 VAC, Part # 001470 or 230 VAC Part # 014197

Repair

Upon notification, Thermo Electron will repair and return within two (2) weeks after receipt of equipment. Charges for repairing are based on time, material and handling.

Figure 7-1. General Applications

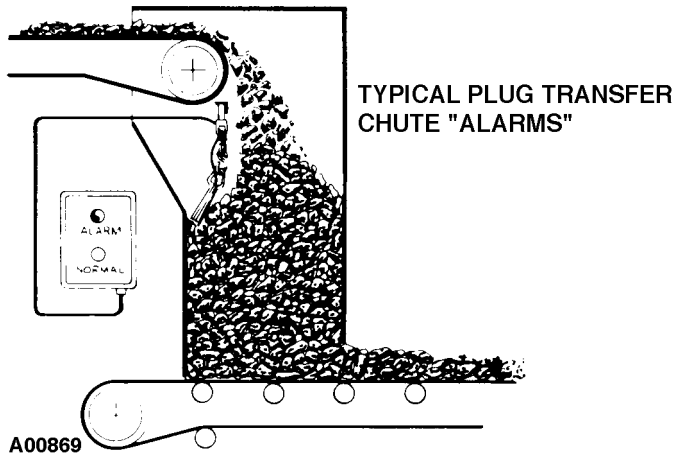
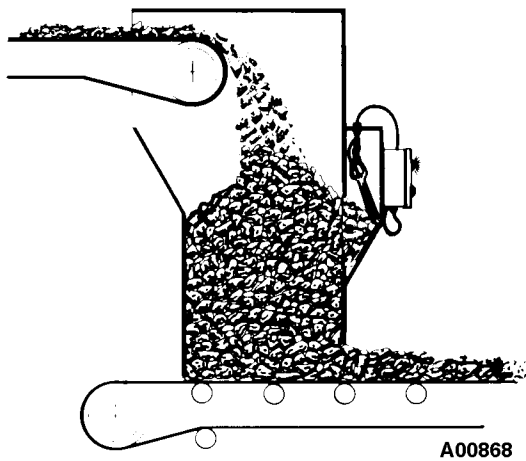
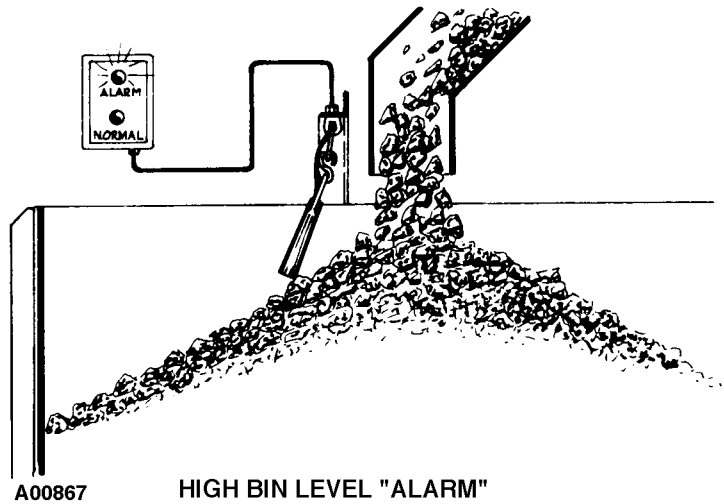

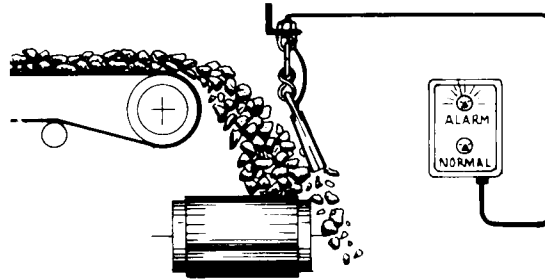

**MATERIAL OVERSHOOTING
TRANSFER CONVEYOR "ALARM"**

A00870

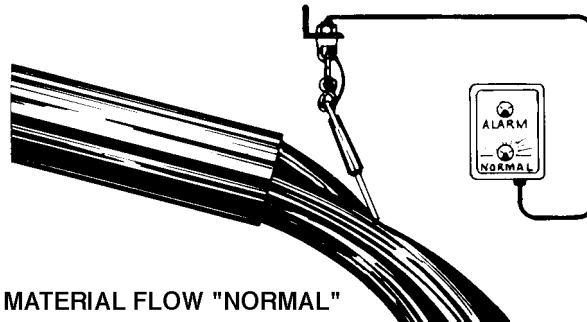

MATERIAL FLOW "NORMAL"

A00871

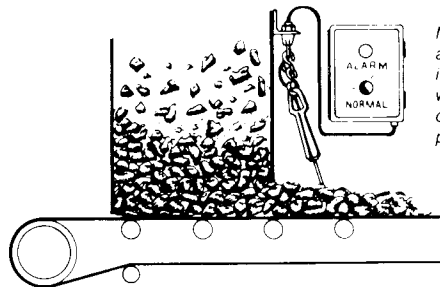

NOTE: In this application probe is equipped with a wear plate for contact with product.

MATERIAL-FLOW "NORMAL"

A00872

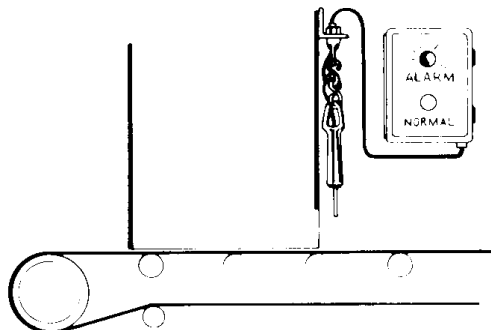

MATERIAL NO FLOW "ALARM"

A00873