

**DTR131 / DTR231
Granuflow
Bulk Solids
Flow Detector**

REC 3957, Rev F
Part No. 050623

DTR131 / DTR231

Granuflow

Bulk Solids

Flow Detector

This document is confidential and is the property of *Thermo Fisher Scientific*. It may not be copied or reproduced in any way without the express written consent of *Thermo Fisher Scientific*. This document also is an unpublished work of *Thermo Fisher Scientific*. *Thermo Fisher Scientific* intends to, and is maintaining the work as confidential information. *Thermo Fisher Scientific* also may seek to protect this work as an unpublished copyright. In the event of either inadvertent or deliberate publication, *Thermo Fisher Scientific* intends to enforce its rights to this work under the copyright laws as a published work. Those having access to this work may not copy, use, or disclose the information in this work unless expressly authorized by *Thermo Fisher Scientific*.

All registered and unregistered trademarks are the property of their respective owners.

Thermo Fisher Scientific
501 90th Ave. NW
Minneapolis, MN 55433 USA
Tel (800) 445-3503
Tel (763) 783-2500
Fax (763) 783-2525
<http://www.thermo.com>

Revision History

Revision A	June 1996	ECO	Release specifics
Revision B	November 1998		
Revision C	September 2000		
Revision D	January 2993	227	Update to Thermo standards
Revision E	March 2003	1014	Update site glass drawing
Revision F	March 2009	2140	

Table of Contents

Table of Contents	i
List of Figures	ii
About this Manual	iii
Who Should Use this Manual?	iii
Organization of the Manual	iii
Documentation Conventions	iii
Safety Messages	iv
General Precaution	iv
How to Get Help	vi
Occupational Safety and Health Act (OSHA)	vi
Thermo Fisher Scientific Warranty	vi
Disclaimer.....	vii
Chapter 1 Introduction	1-1
1.1 General	1-1
1.2 Measuring System.....	1-1
1.3 Principle of Operation.....	1-1
1.4 Specifications for DTR 131	1-2
1.5 Wiring.....	1-4
1.6 General Rules of Mounting.....	1-6
1.6.1 Mounting the DTR 131	1-6
1.6.2 Mounting the DTR 231	1-9
1.6.3 Installation at an Angle to the Material Flow (DTR 131 and DTR 231).....	1-11
Chapter 2 Switch Adjustments	2-1
2.1 Fail Safe	2-1
2.2 Time Delay	2-2
2.3 Recommended Switch Positions	2-2
Chapter 3 Adjusting DTR for Material Flow	3-1
3.1 General	3-1
3.2 LED Adjustment Method.....	3-1
3.3 Voltmeter Adjustment Method	3-1
Chapter 4 Maintenance	4-1
4.1 General	4-1
Chapter 5 Function Test	5-1
5.1 General	5-1
Chapter 6 Applications	6-1
Chapter 7 Replacement Parts	7-1
7.1. General	7-1
7.2. Order Information	7-1
7.3. Parts List.....	7-5
7.4. Mounting Kit Drawings.....	7-6

List of Figures

Figure 1-1	DTR 131 Mounting Dimensions	1-3
Figure 1-2	DTR 231 Remote Housing Mounting Dimensions	1-4
Figure 1-3	Wiring and Relay Connections	1-5
Figure 1-4	Voltage Selection Jumper Settings	1-5
Figure 1-5	Mounting Layout	1-7
Figure 1-6	DTR Mounting Dimensions	1-7
Figure 1-7	Standoff Specifications Duct Wall Mount.....	1-8
Figure 1-8	Inspection Glass Mounting.....	1-8
Figure 1-9	Standoff Specifications	1-9
Figure 1-10	Mounting Detail Longitudinal Cams A	1-10
Figure 1-11	Mounting Detail Guide Holes A	1-10
Figure 1-12	Remove Housing	1-11
Figure 1-13	Auger Supply	1-11
Figure 1-14	Rotary Feeder.....	1-11
Figure 1-15	Bulk Material Profile.....	1-12
Figure 2-1	Time Delay Selection S102.....	2-1
Figure 2-2	Time Delay Selection S103.....	2-2
Figure 2-3	Switch Locations and Voltage Meter Hookup	2-3
Figure 3-1	Voltmeter Adjustment Method.....	3-2
Figure 6-1	Monitor Flow of Aluminum Intake.....	6-1
Figure 6-2	Monitor Supply of Ingredients	6-1
Figure 7-	Mounting Kits	7-6

About this Manual

This manual provides installation, troubleshooting, and repair information for the *DTR131 / DTR231 Granuflow Bulk Solids Flow Detector* system manufactured by *Thermo Fisher Scientific*.

Who Should Use this Manual?

The *DTR131 / DTR231 Granuflow Bulk Solids Flow Detector* is a learning resource and reference for anyone concerned with the operation of the *Flow Detector*.

Organization of the Manual

This manual is organized into 7 chapters:

Chapter 1: System Information

Chapter 2: Switch Adjustments

Chapter 3: Adjusting DTR for Material Flow

Chapter 4: Maintenance

Chapter 5: Function Test

Chapter 6: Applications

Chapter 7: Replacement Parts

Documentation Conventions

The following conventions are used in this manual to help easily identify certain types of information:

- *Italic* is used to introduce new terms and for emphasis.
- *Italic/blue* type is used for references to other sections of the manual and serve as links in electronic documents.
- The names of setup, calibration displays, menu displays, and variables are shown in **SMALL CAPS**.
- The names of keys are shown in **BOLD CAPITALS**.



▪ **Note:** Provides information of special importance to the reader.

- This symbol indicates a **HINT** in the text that may be of value but not necessary for operation.

Safety Messages

Instructions in this manual may require special precautions to ensure the safety of the personnel performing the operations.



Please read the safety information before performing any operation preceded by this symbol.

There are two levels of safety messages: warnings and cautions. The distinction between the two is as follows:

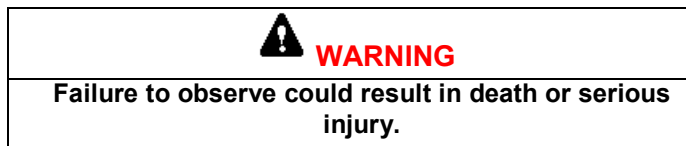

General Precaution

Do not install, operate, or perform any maintenance procedures until you have read the safety precautions presented.

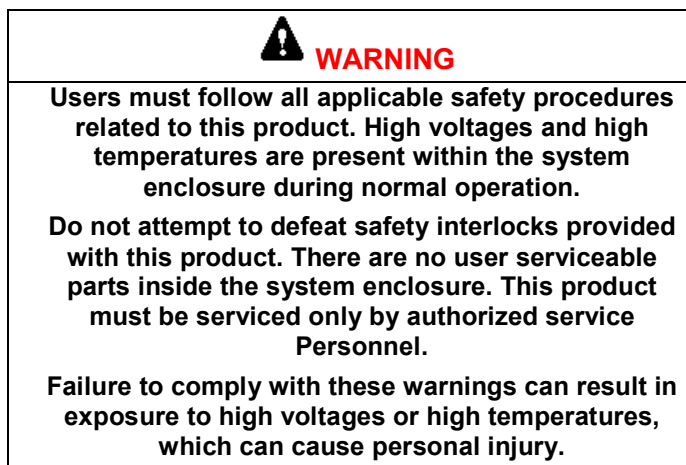

**WARNING**

Failure to follow safe installation and servicing procedures could result in death or serious injury.

- Make sure only qualified personnel perform installation and maintenance procedures in accordance with the instructions in this manual.
- Allow only qualified electricians to open and work in the electronics cabinet, power supply cabinet, control cabinet, or switch boxes.
- Covers over the electronics and rotating parts must always remain in place during normal operation. Remove only for maintenance, with the machine's power OFF. Replace all covers before resuming operation.
- During maintenance, a safety tag (not supplied by the factory) is to be displayed in the ON/OFF switch areas instructing others not to operate the unit (ANSI:B157.1).

**WARNING**

High voltage that may be present on leads could cause electrical shock.

- All switches must be OFF when checking input AC electrical connections, removing or inserting printed circuit boards, or attaching voltmeters to the system.
- Use extreme caution when testing in, on, or around the electronics cabinet, PC boards, or modules. There are voltages in excess of 115 V or 230 V in these areas.

**WARNING**

Use only the procedures and new parts specifically referenced in this manual to ensure specification performance and certification compliance. Unauthorized procedures or parts can render the instrument dangerous to life, limb, or property.

**WARNING**

This machine should not be operated at more than the production rate stated on your Equipment Specification sheet or used in applications other than those stated in the original order.

How to Get Help

 WARNING
<p>Unless you re directed to do so by an authorized service representative of <i>Thermo Fisher Scientific</i>, you should not attempt to perform any troubleshooting or maintenance procedures that are not described in this manual.</p> <p>Failure to comply with these warnings can result in exposure to high voltages or high temperatures, which can cause personal injury.</p>

Occupational Safety and Health Act (OSHA)

The *Occupational Safety and Health Act* clearly places the burden of compliance on the user of the equipment and the act is generalized to the extent that determination of compliance is a judgment decision on the part of the local inspection. Hence, *Thermo Fisher Scientific* will not be responsible for meeting the full requirements of OSHA in respect to the equipment supplied or for any penalty assessed for failure to meet the requirements, in respect to the equipment supplied, of the *Occupational Safety and Health Act*, as interpreted by an authorized inspector. *Thermo Fisher Scientific* will use their best efforts to remedy such violation at a reasonable cost to the buyer.

Thermo Fisher Scientific Warranty

The seller agrees, represents, and warrants that the equipment delivered hereunder shall be free from defects in material and workmanship. Such warranty shall not apply to accessories, parts, or material purchased by the seller unless they are manufactured pursuant to seller's design, but shall apply to the workmanship incorporated in the installation of such items in the complete equipment. To the extent purchased parts or accessories are covered by the manufacturer's warranty, seller shall extend such warranty to buyer.

Seller's obligation under said warranty is conditioned upon the return of the defective equipment, transportation charges prepaid, to the seller's factory in Minneapolis, Minnesota, and the submission of reasonable proof to seller prior to return of the equipment that the defect is due to a matter embraced within seller's warranty hereunder. Any such defect in material and workmanship shall be presented to seller as soon as such alleged errors or defects are discovered by purchaser and seller is given opportunity to investigate and correct alleged errors or defects and in all cases, buyer must have notified seller thereof within one (1) year after delivery, or one (1) year after installation if the installation was accomplished by the seller.

Said warranty shall not apply if the equipment shall not have been operated and maintained in accordance with seller's written instructions applicable to such equipment, or if such equipment shall have been repaired or altered or modified without seller's approval; provided, however, that the foregoing limitation of warranty insofar as it relates to repairs, alterations, or modifications, shall not be applicable to routine preventive and corrective maintenance which normally occur in the operation of the equipment.

“EXCEPT FOR THOSE WARRANTIES SPECIFICALLY CONTAINED HEREIN, SELLER DISCLAIMS ANY AND ALL WARRANTIES WITH RESPECT TO THE EQUIPMENT DELIVERED HEREUNDER, INCLUDING THE IMPLIED WARRANTIES OF MERCHANTABILITY AND FITNESS FOR USE. THE SOLE LIABILITY OF SELLER ARISING OUT OF THE WARRANTY CONTAINED HEREIN SHALL BE EXCLUSIVELY LIMITED TO BREACH OF THOSE WARRANTIES. THE SOLE AND EXCLUSIVE REMEDY FOR BREACH OF THE WARRANTIES SET OUT ABOVE SHALL BE LIMITED TO THE REPAIR OR REPLACEMENT OF ANY DEFECTIVE ACCESSORY, PART OR MATERIAL WITH A SIMILAR ITEM FREE FROM DEFECT, AND THE CORRECTION OF ANY DEFECT IN WORKMANSHIP. IN NO EVENT SHALL SELLER BE LIABLE FOR ANY INCIDENTAL OR CONSEQUENTIAL DAMAGES.”

Purchaser agrees to underwrite the cost of any labor required for replacement; including time, travel, and living expenses of a *Thermo Fisher Scientific* Field Service Engineer at the closest factory base.

Thermo Fisher Scientific

501 90th Ave. NW

Minneapolis, MN 55433

Phone: (800) 445-3503

Phone: (763) 783-2500

Fax: (763) 783-2525

Disclaimer

Though the information provided herein is believed to be accurate, be advised that the information contained herein is *not* a guarantee for satisfactory results. Specifically, this information is neither a warranty nor guarantee, expressed or implied, regarding performance, merchantability, fitness, or any other matter with respect to the products, and recommendation for use of the product/process information in conflict with any patent. Please note that *Thermo Fisher Scientific* reserves the right to change and/or improve the product design and specifications without notice.

Chapter 1

Introduction

1.1 General

The Granuflow bulk material detector, a unique and innovative contribution to the process control industry, is a microwave-based detector operating on the principle called the Doppler effect. The Granuflow monitors the movement of bulk materials and can be used to detect and indicate material blockages or feeder shutdowns.

Available in self-contained (DTR 131) and remote (DTR 231) configurations, these noncontact motion sensors are ideal for monitoring bulk material flow in pipelines, ducts, air slides, and at transfer points of vibrating chutes, conveyor belts, screw feeders, and elevators.

1.2 Measuring System

The complete Granuflow system consists of a transmitter and transducer. The DTR 131 is the standard Granuflow system and is an integral unit containing both the transmitter and transducer inside an IP65 housing.

The transducer has a Gunn diode configured within a waveguide (horn) antenna and functions as both a microwave transmitter and receiver. The transmitter contains the measuring electronics and relay output.

There are two versions of the DTR 131 available. The standard version conforms to European CE regulations and is for use in non-hazardous locations. The second version is FM approved for use in Class II, Div. 1, Groups E, F, and G hazardous locations and is CSA approved for non-hazardous locations.

The DTR 231 is the remote configuration of the Granuflow system. Accordingly, the transmitter is in an IP54 enclosure which weighs less than the DTR 131; the transducer is mounted in a separate case. A 6.5 foot (2 meter) extension cable (sheathed with flexible metal conduit) connects the transducer with the transmitter for remote mounting. The DTR 231 also conforms to CE regulations, but is not available in an FM or CSA approved model.

1.3 Principle of Operation

A Gunn diode produces microwave energy at a fixed frequency. The waveguide (or horn) antenna beams directional microwave energy (24.125 GHz) toward the process material. The microwaves are reflected by the bulk material and received again by the sensor/transducer. If the reflecting medium is moving, there will be, in accordance with the Doppler effect, a frequency shift between the transmitted and the received signals. The frequency shift is proportional to the velocity of the process material. The transducer superimposes the transmitted and received signals. Since the two frequencies differ only slightly, the differential signal produced is low frequency. This low frequency signal is delivered to the electronics by capacitive coupling and processed in a low frequency amplifier.

Set the amplification by using a step switch for coarse adjustment and a potentiometer for fine adjustment. The low frequency signal is rectified and fed to a threshold value amplifier. An LED indicates whether the switch threshold has been crossed when setting the amplifier.

A switch can be actuated to select the safety function of the instrument according to the monitoring requirements of the application. These safety functions are: the relay de-energizes when the material flow is interrupted or if the primary power fails; and the relay de-energizes when the material is flowing or if the primary power fails.

A second switch is used to select ON or OFF delay of the relay. Time delay duration is adjustable from one to ten seconds.

The DTR 131 has been certified to comply with the applicable limits set forth in Part 15 of the FCC Rules. Part 15 sets out the regulations under which this device may be operated without an individual license. Changes or modifications not expressly approved by Thermo Fisher Scientific may void your authority to operate this equipment under Part 15.

The DTR 131 emits microwave energy at a level of 0.15 mW/cm² (measured at the antenna horn), which is much lower than the internationally agreed safety level of 10 mW/cm². The Safety Standard ANSI/IEEE C95.1-1992 was established by the American National Council on Radiation Protection and Measurement (NCRP).

1.4 Specifications for DTR 131

Note: All dimensions are in inches (Figures 1-1 and 1-2), metric equivalents are in brackets; for example; in. (mm).

Housing:		Cast aluminum
Protection:	DTR 131	IP 65 (NEMA 4)
	DTR 231	IP 54 (NEMA 4)
Ambient Temperature (Housing):		-4° to +140° F (-20° to +60° C)
Maximum Temperature on Sensor		176° F (80° C)
Horn Surface:		
Weight:	DTR 131	Approximately 4.4 lb (2 kg)
	DTR 231	Approximately 5.9 lb (2.7 kg)
Maximum Operating Pressure:		14.5 PSI (1 bar)
Power Supply Options:		100 VAC Jumper configurable for 200 VAC
CE Models		230 VAC Jumper configurable for 115 VAC
		24 VDC
FM/CSA Models		115 VAC Jumper configurable for 230 VAC
Power Supply Tolerance		15% - 10%
Power Consumption		Approximately 11.8 VA

Operating Frequency (Microwaves):	24.124 GHz (standard) 24.200 GHz (special UK version)
Detection Range:	0-60 in. (0-1.5 m) (depending on the application)
Relay Output-Contact Ratings	Max. 250 V, max. 4 A, max. 500 VA, (AC) Max. 100 W (DC)
Switching Delay:	ON or OFF delay (selectable); switching delay adjustable from 2 to 10 seconds.
Conduit Connections:	
CE Models	2 PG16 Ports
M/CSA, Japanese Models	PG16 to ½ NPT Converter, PG16 Ports
Transducer Mounting	Special slotted aluminum flange DN 40, PN 6 to connect counter flange DIN 2501 or ANSI 150 RF
Options:	HF Permeable window with flange. Mounting bracket (works w/window or standalone). Pipe standoff w/mounting flange (90°). Pipe standoff w/mounting flange (45°).

Figure 1-1 DTR 131 Mounting Dimensions

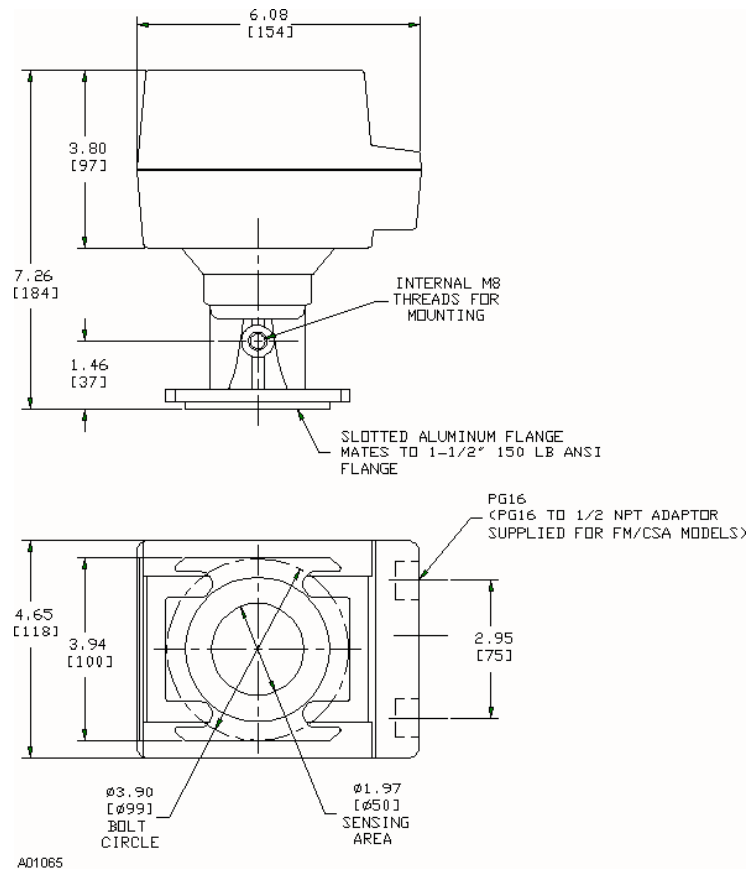
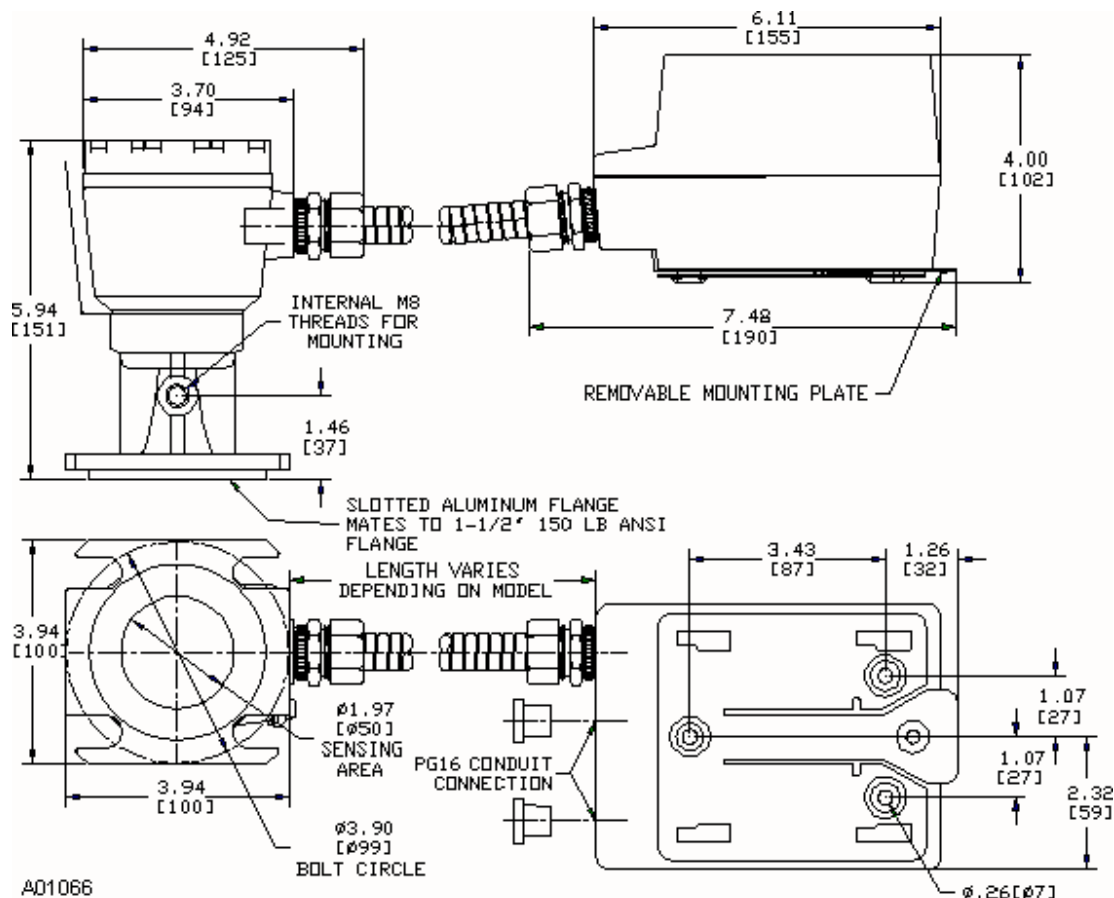

Figure 1-2 DTR 231 Remote Housing Mounting Dimensions



1.5 Wiring

Wiring connections for the Granuflow units are shown in Figures 1-3 and 1-4. The terminal block is located on the lower printed circuit board in the transmitter. Maximum wire size allowed is 12 AWG.

NOTE: Care should be taken to avoid ingress of moisture via conduit. Drip loops or conduit runs which slope down from the enclosure are suggested in conjunction with sealing of conduit entries with a silicone rubber product. Unused conduit entries should be closed with a means appropriate to the installation environment.

NOTE: PG 16 conduit connections are standard on both the DTR 131 and DTR 231. FM approved units come with two PG 16 to ½ NPT adaptors.

NOTE: A readily accessible disconnect device shall be incorporated in the fixed wiring.

NOTE: Building installation should provide short circuit backup protection. Operating current specified in Section 0

NOTE: A user supplied over-current protection device must be installed in the wiring circuit to the relay contacts, or the FM approval is void.

Figure 1-3 Wiring and Relay Connections

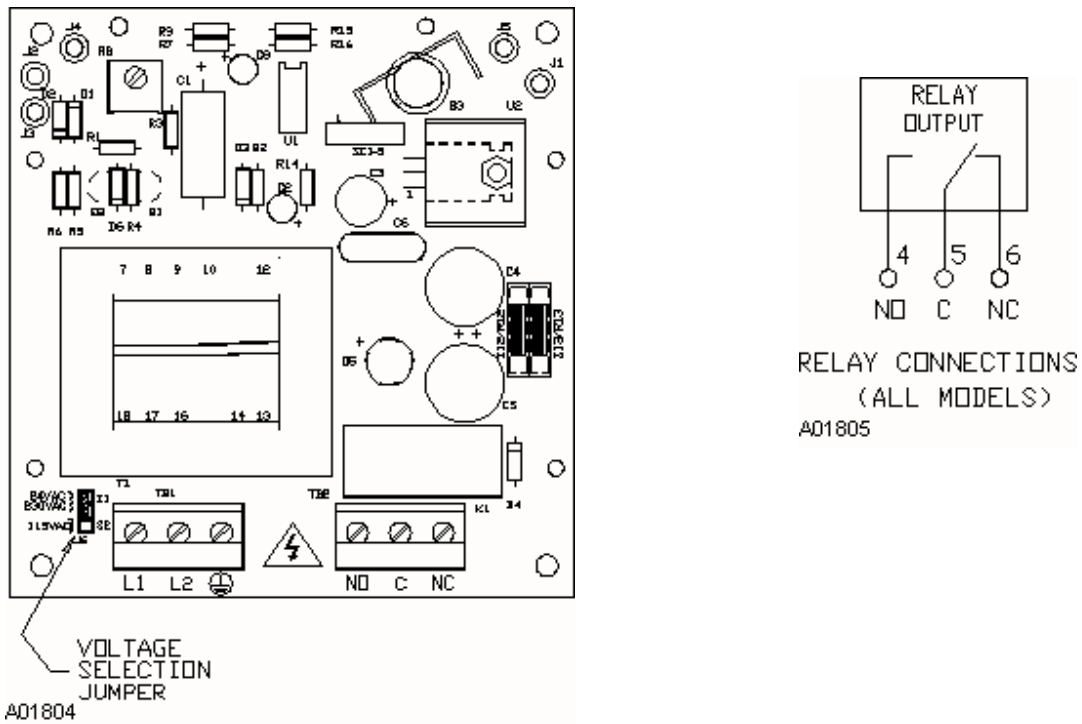
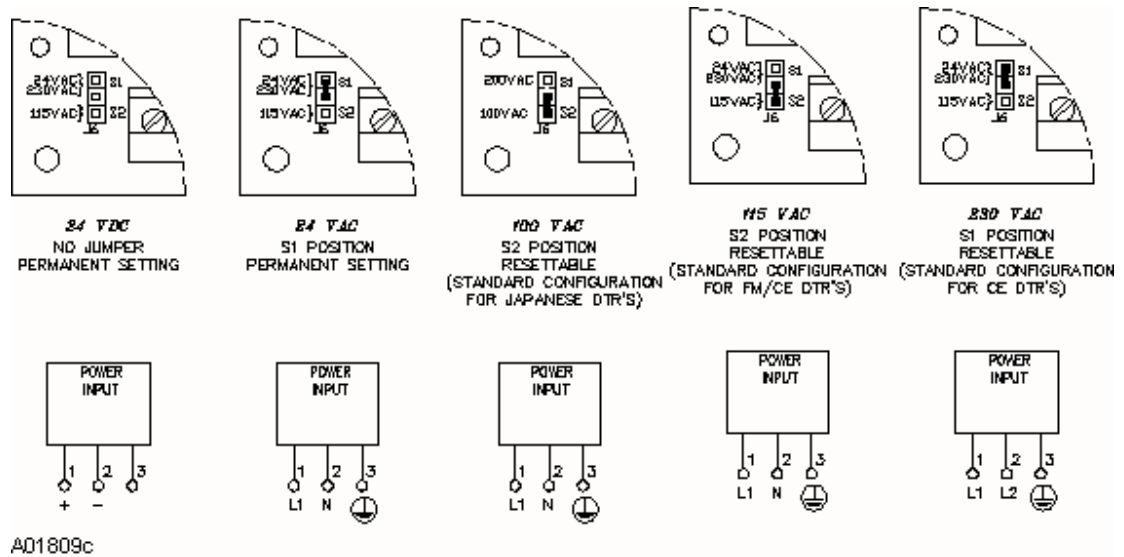

Figure 1-4 Voltage Selection Jumper Settings



1.6 General Rules of Mounting

General rules include:

- When the material flow stream is sharply defined, the Granuflow may be mounted so that the axis of the horn is perpendicular to the material flow. Exceptions and special cases are discussed in Section 0, Figure 1-13 and 1-14.
- Motion creates the frequency shift which enables detection of flow; stationary bulk material or deposit buildup are not detected. The movement is normally produced by the process material. To prevent false detection, however, certain precautions should be exercised:
 1. Process equipment which moves within the range of the Granuflow beam may be misinterpreted as material flow. (For example; flopping conveyor belts, mixing blades.) To avoid this misinterpretation, insure such moving parts are outside the user-adjusted detection range, in cases where the process material flow is closer to the Granuflow sensor than is the moving equipment. In other cases, it may be prevented by shielding the moving parts with a stationary metal sheet or plate.
 2. Motion of the Granuflow sensor itself can cause a difference between the true reflected frequency and the apparent detection frequency. Rigid mounting of the sensor should be insured.

NOTE: Normal minor vibration in the mounting will not create measuring errors

1.6.1 Mounting the DTR 131

Mounting the DTR 131 depends on the particular features of the actual application. The DTR 131 can be mounted in two ways:

1. Directly on a duct wall (see Figure 1-5 and Figure 1-6).

The DTR 131 can be mounted directly on a duct wall (see Figure 1-5 if the wall is flat and stable and if the mean temperature and pressure in the vessel are within the limits of the unit (see Section 4, Specifications).

For the drilling template for mounting the DTR directly to the duct wall, see Figure 1-6

Figure 1-5 Mounting Layout

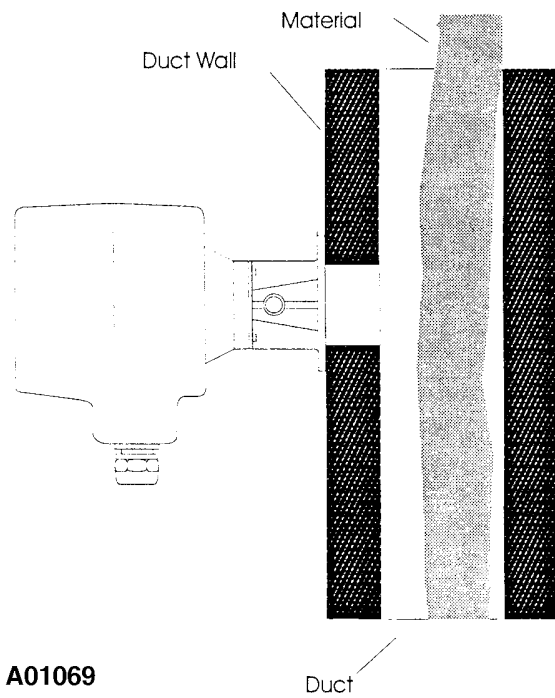
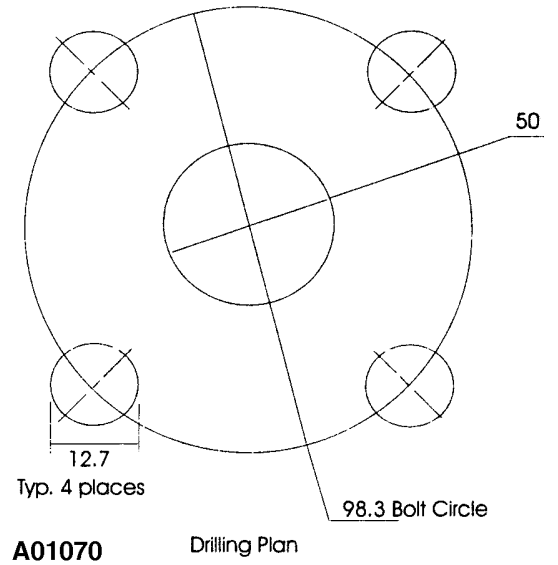
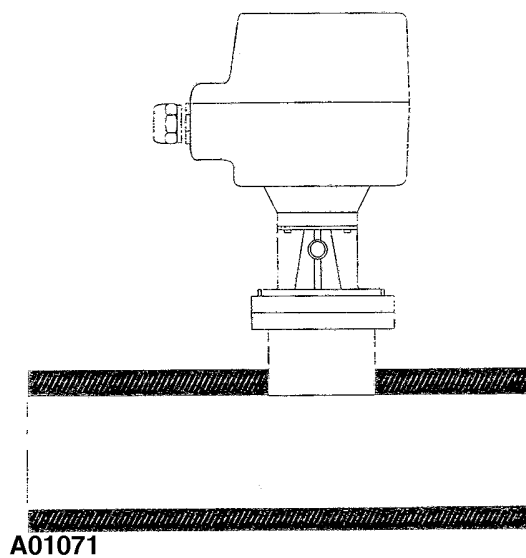

Figure 1-6 DTR Mounting Dimensions



Use the flange mounting when conveying equipment is used or when the antenna axis is not perpendicular to material flow. The standoff should be as short as possible, with minimum length of 1 in. (25 mm). When the material temperature is slightly higher than 140° F (60° C), a longer standoff may be used. In most cases, a minimum tube diameter of 4 in. (100 mm) must be observed in order to maintain attenuation within reasonable bounds. Some applications work well with smaller diameter flows. The detection range (a function of the application parameters) must be considered when deciding the standoff length (Figure 1-7).

Figure 1-7 Standoff Specifications Duct Wall Mount



2. With a mounting bracket alone or in conjunction with an inspection glass assembly (see Figure 1-8).

Figure 1-8 Inspection Glass Mounting

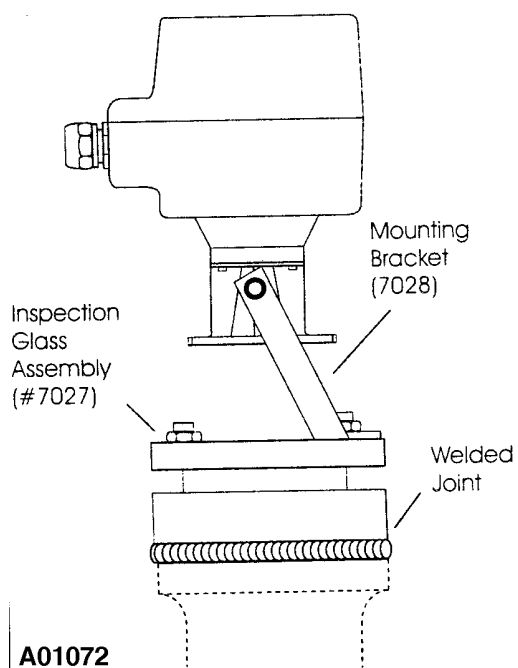

In closed vessel applications where the process pressure is greater than 1 bar, the Granuflow should be fitted with an inspection glass assembly with a microwave permeable window. This increases the maximum pressure to 145 PSI (10 BAR) and the maximum temperature to 545° F (285° C). (Dimensions of the window and mounting bracket are at the end of this manual.)

To prevent conductive deposits from forming in the standoff, close the standoff with a plug or disk made of PVC or PTFE (see Figure 1-9). On conveyor equipment, the plug should project into the duct approximately .1 in. (3 mm) for self-cleaning. Fasten the plug to the outside wall with a screw to prevent the plug from being dragged into the process flow (as a result of vibration or material flow).

Figure 1-9 Standoff Specifications

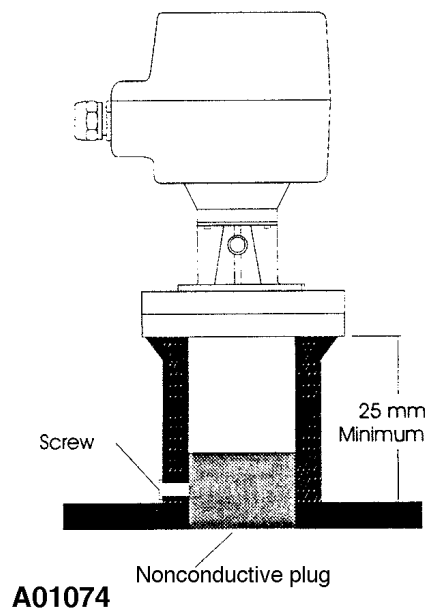

There are two kits available for mounting the DTR with a standoff. They include a metal pipe with a 150 lb (equivalent to DIN 2501) flange welded on one end and a plastic plug for the pipe. One kit is for mounting perpendicular to the flow (90°) and the other is for mounting at an angle to the flow (45°). Dimensions for these kits are shown in Figure 7-1.

1.6.2 Mounting the DTR 231

The DTR 231 comes with a mounting plate for the transmitter enclosure. Mounting guidelines for the DTR 131 also apply to the DTR 231.

First, attach the mounting plate to the surface that will support the DTR with screws. Then, attach the housing to the mounting plate by following these steps:

1. Guide the housing from the front, with the longitudinal cams A at the rear of the instrument (Figure 1-10), down into the guide holes A (Figure 1-11).
2. Push the housing down until the round cam B clicks into drill hole B.

Figure 1-10 Mounting Detail Longitudinal Cams A

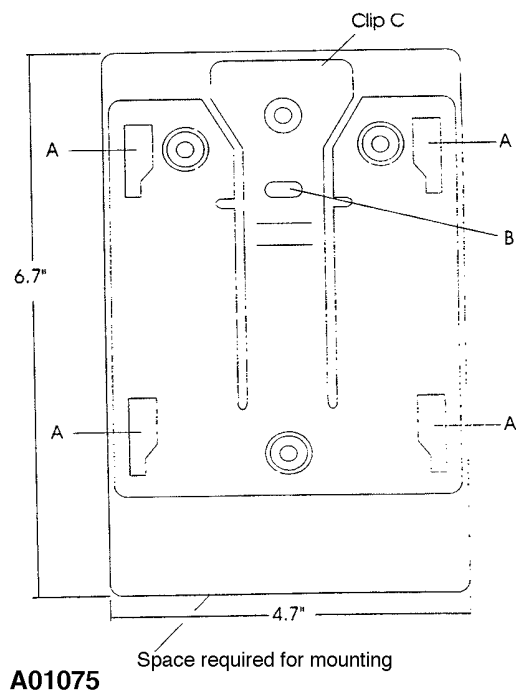
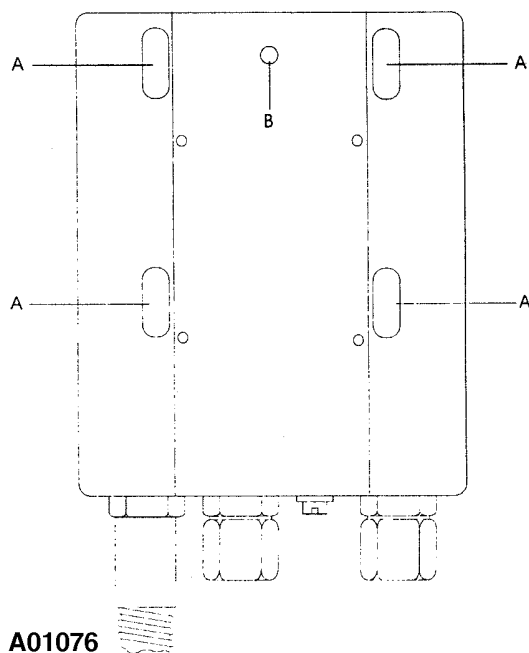

Figure 1-11 Mounting Detail Guide Holes A



To remove the housing from the mounting plate:

1. With a screwdriver, press Clip C against the wall (Figure 1-12).
2. Slide the housing upward. DO NOT strike or force.

Figure 1-12 Remove Housing

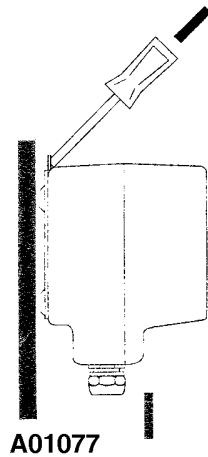

1.6.3 Installation at an Angle to the Material Flow (DTR 131 and DTR 231)

As previously stated, the Granuflow units should generally be mounted so that the axis of the sensor is perpendicular to the material flow. There are, however, two circumstances in which it is recommended the Granuflow units be mounted at an angle to the bulk material flow. These exceptions are:

1. When moving parts (for example, parts of a constantly moving conveyance system) can be misinterpreted as material flow. This situation can be avoided by mounting the Granuflow in a position where the microwave beams will be directed away from the moving parts (Figure 1-13). If that is not possible, mount the Granuflow at an angle to the material flow by using a mounting kit or a mounting bracket (Figure 1-14). (Refer to Figure 7-1.)

Figure 1-13 Auger Supply

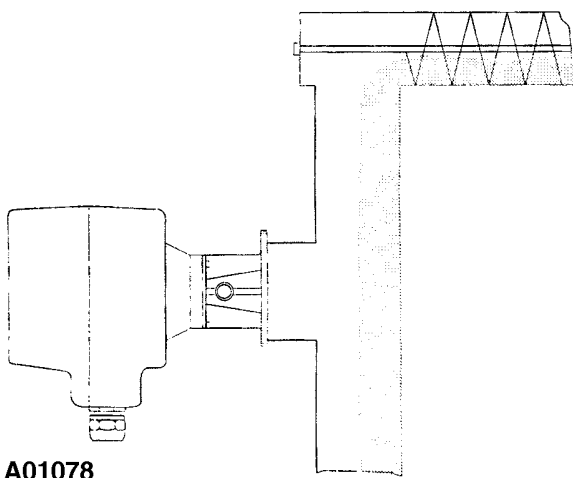
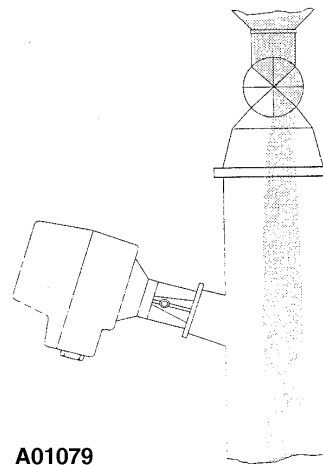

Figure 1-14 Rotary Feeder



When the process material has such a low velocity for reflection diffusion, as to be undetectable even at the maximum sensitivity setting. Angle mounting increases the component of the velocity which is parallel to the sensor axis, producing larger and detectable reflection frequency shifts (see Figure 1-15).

NOTE: Use a mounting bracket if specific features of the installation rule out flange mounting at an angle. This makes it easier to change the angle for different application conditions, if necessary

Figure 1-15 Bulk Material Profile

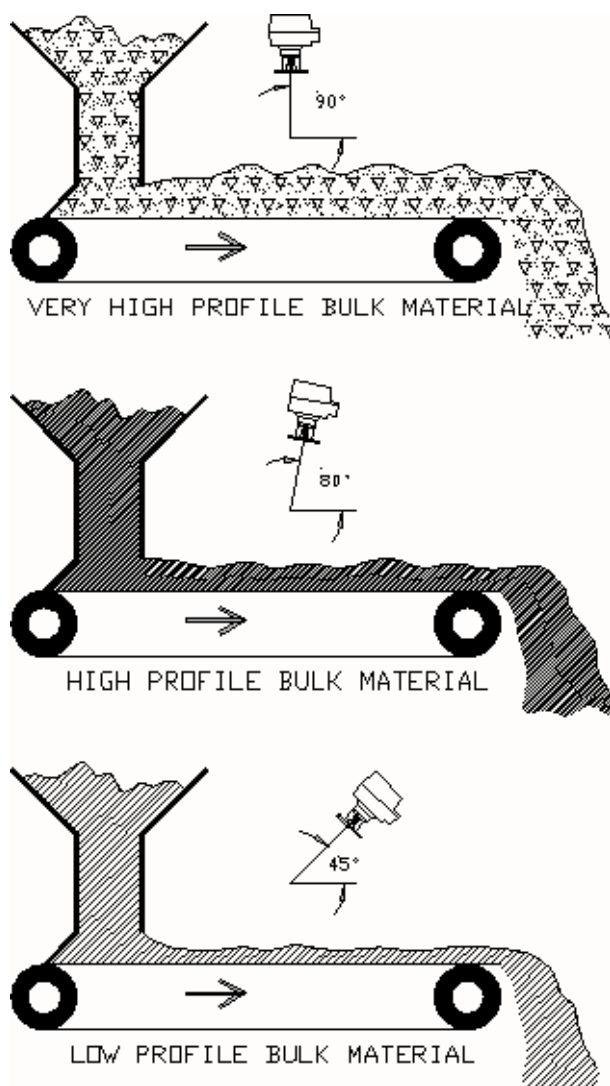

A01806

Chapter 2

Switch Adjustments

NOTE: Switch locations are shown in

Figure 2-1.

2.1 Fail Safe

Switch S102 is used to control how the relay functions. The position of S102 determines whether no flow or material flow energizes the relay. The setup below assumes the relay is wired to an alarm, which can be turned on in two ways - achieving specified flow condition or power failure.

If S102 is UP, then the relay is energized for no flow.

If S102 is DOWN, then the relay is energized for flow.

When the relay is energized, current will flow from NO to C only.



When the relay is de-energized, current will flow from C to NC only.

To Turn on an alarm for flow, set S102 UP and wire alarm power through C and NC. When the flow starts, the relay will de-energize and allow current to flow from C to NC, turning power on to the alarm. In addition, if the power is disconnected to the DTR, the relay will de-energize, turning power on to the alarm.

To turn on an alarm for no flow, set S102 DOWN and wire alarm power through C and NC. When the flow stops, the relay will de-energize and allow current to flow from C to NC, turning on power to the alarm. In addition, if the power is disconnected to the DTR, the relay will de-energize, turning power on to the alarm.

Application Conditions		Recommended S102 Position	Resulting Status of Relay	
Normal Operation	Alarm Condition		During Normal Condition	During Alarm Condition
Material Flow	Material Blockage or No Material	Down	Energized	De-energized
No Material Flow	Material Flow	Up	Energized	De-energized

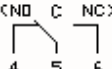
Figure 2-1 Time Delay Selection S102

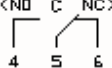
SWITCH POSITION	SYMBOL	FUNCTION
S102 	<NO C NC> 	NO MATERIAL FLOW/ ALARM RELAY ENERGIZED
S102 	<NO C NC> 	NO MATERIAL FLOW/ ALARM RELAY DE-ENERGIZED

Thermo Fisher Scientific
REC-3957 Rev F





2.2 Time Delay

Use switch S103 to select an appropriate time delay. S103's position determines whether the relay is delayed "ON" (energizing) or delayed "OFF" (de-energizing).

Figure 2-1 and Figure 2-3 illustrate switch positions and their corresponding functions. You may adjust the time delay from 1 to 10 seconds; the desired duration depends upon the flow velocity and properties of the bulk material.

Rotate the potentiometer R137 completely counterclockwise for a one-second time delay; rotate it completely clockwise for a 10-second delay. (See Figure 2-3)

Figure 2-2 Time Delay Selection S103

SWITCH POSITION	SYMBOL	FUNCTION
S103 		...ON DELAY (DELAY OF RELAY ENERGIZATION)
		...OFF DELAY (DELAY OF RELAY DE-ENERGIZATION)

A01807

2.3 Recommended Switch Positions

Alarm Condition	Switch S102	Switch S103
Material blockage	Down	Down ("OFF" delay) if the material flow is intermittent
Material flow	Up	Down ("OFF" delay) if single pieces or batches of material are expected before a steady material flow

Figure 2-3 Switch Locations and Voltage Meter Hookup

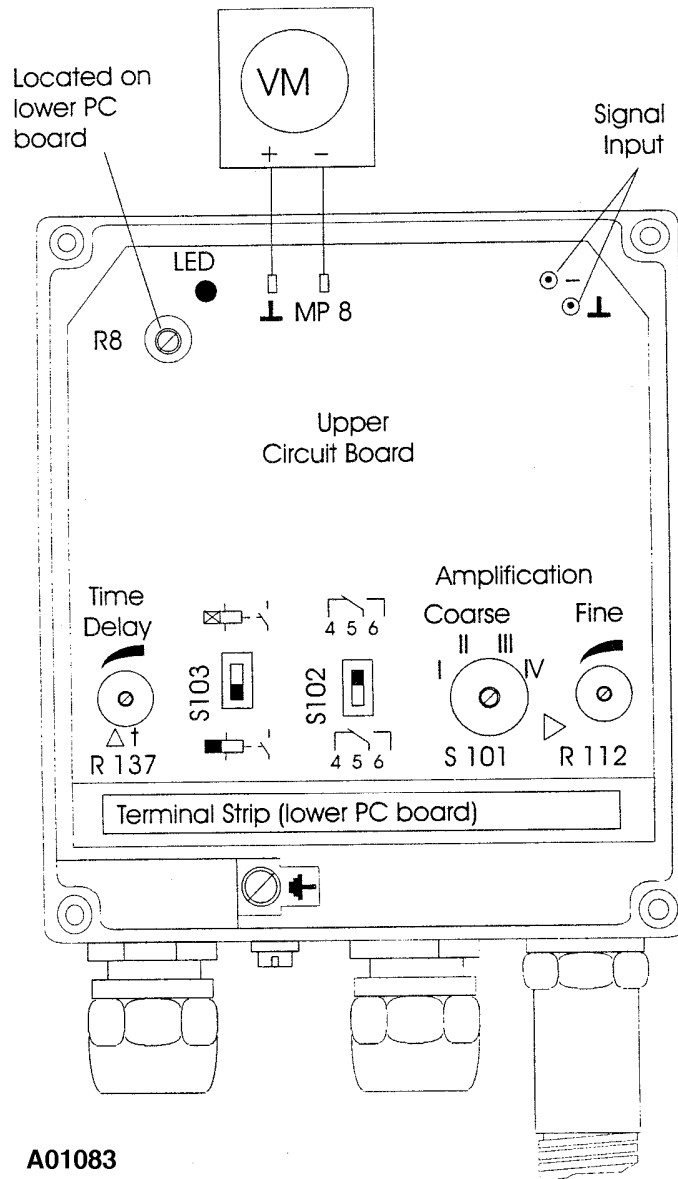

NOTE: On coarse setting I is lowest sensitivity and IV is highest sensitivity.

Chapter 3

Adjusting DTR for Material Flow

3.1 General

The DTR can be adjusted for material flow by turning the potentiometer and switch on the upper circuit board and observing the LED, or by using a voltmeter. Either method is acceptable, but the voltmeter method gives a better understanding of the DTR functions

3.2 LED Adjustment Method

1. Turn the potentiometer R137 (time delay) completely counterclockwise (shortest time delay).
2. Place switch S101 (coarse amplification) on setting I (smallest amplification).
3. Turn the potentiometer R112 (fine amplification) completely counterclockwise (smallest amplification).
4. Allow the material to flow.
5. Increase amplification via R112 (clockwise rotation) until the LED lights. If it does not light, proceed to step 6.
6. Increase amplification by switching S101 to the next higher setting(s) until the LED lights.
7. Rotate R112 counterclockwise until the LED goes off. Rotate R112 clockwise until the LED just lights.
8. When the material flow stops, the LED should go out.

3.3 Voltmeter Adjustment Method

1. Connect a voltmeter to the Granuflow transmitter between MP8 and ground (see Figure 2-3).
2. Turn the potentiometer R137 (time delay) completely counterclockwise (shortest time delay).
3. With the equipment in operation and material flowing, set switch S101 (coarse amplification) to setting I.
4. Turn the potentiometer R112 (fine amplification) completely counterclockwise.
5. Rotate the potentiometer R112 clockwise until the voltmeter displays a value greater than 6.2 V (see Figure 3-1).
6. If unsuccessful in accomplishing step 5, turn the potentiometer R112 completely counterclockwise and set S101 at setting II. Now repeat step 5.
7. Stop the material flow. The voltmeter should indicate less than 3.2 V.

NOTE: For the most reliable adjustments, use 6.5 V for step 5 and 3 V for step 7 to obtain reliable adjustment (Figure 3-1). The difference in voltage is critical to clearly differentiate between material flow and no material flow.

Figure 3-1 Voltmeter Adjustment Method

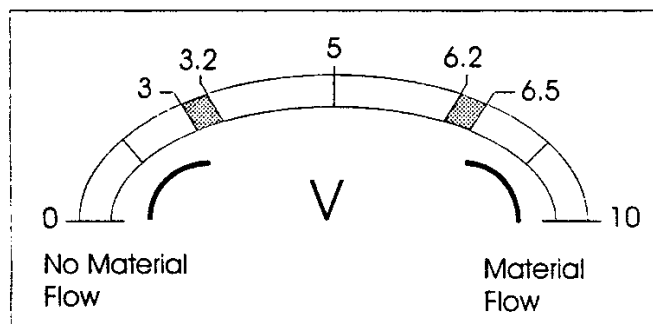

A01084

If the higher voltage reading cannot be obtained, the maximum detection range may be restricted:

- by properties of the material flow
- as a result of installation
- because the tube is too narrow
- because the plug causes too much attenuation
- because distance between the flow and the sensor is too great

If the lower voltage reading cannot be obtained, the Granuflo is probably subject to some outside movement such as vibration.

Chapter 4 Maintenance

4.1 General

The Granuflow systems require no maintenance.

Service Information

Chapter 5

Function Test

5.1 General

If the Granuflow malfunctions, perform the following function test: moving a hand in front of the sensor should cause the LED to light and the relay to switch (within the time allowed by the time delay setting). The test distance is dependent upon the amplification setting (and hence, range). If the LED does not light and the relay does not switch, contact Thermo Fisher Scientific.

Chapter 6 Applications

Application	Aluminum Industry
Problem	Monitor the flow of aluminum intake to reduce environmental pollution.
Solution:	Adding alumina acetate to the stream of polluting and poisonous waste gases traps the poisonous particles in the gas and can be deposited in the filter. The Granuflow insures an uninterrupted supply of alumina which reduces environmental pollution (Figure 6-1)
Application	Animal Feed Industry
Problem:	Monitor the supply of ingredients to insure a quality product and prevent equipment failure
Solution:	A typical animal feed processing application involves measuring the ingredient dosages with an impact flow meter and an inductive flowmeter. If the impact flowmeter, measuring the animal feed, jams and the molasses continues to be supplied to the mixer through the inductive flow meter, damage may be done to the mixer. The cleaning and repair of the mixer causes expensive down time. Monitoring the supply of animal feed with the Granuflow and stopping the supply of molasses immediately when no movement of animal feed is sensed is the most efficient solution. (See Figure 6-2)

Figure 6-1 Monitor Flow of Aluminum Intake

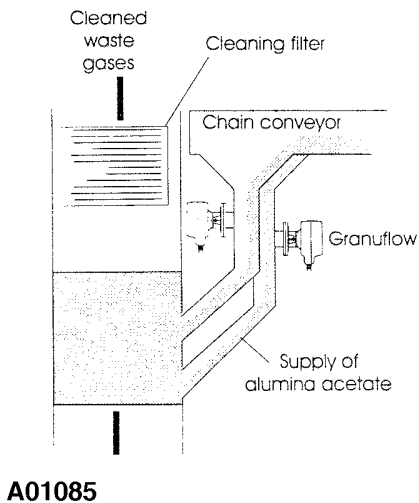
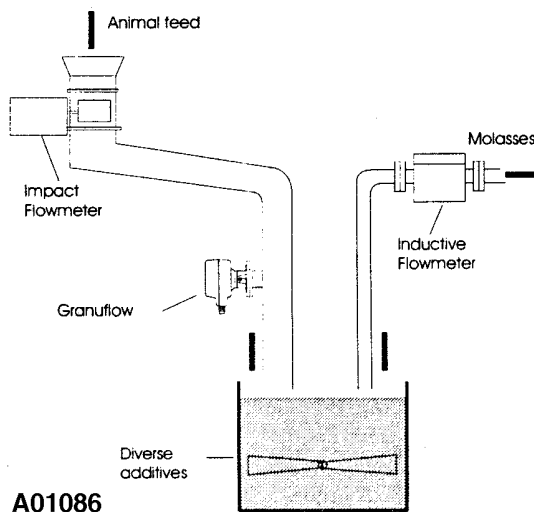

Figure 6-2 Monitor Supply of Ingredients



Chapter 7

Relacement Parts

7.1. General

This section gives information on how to order replaceable parts for your Granuflow.

7.2. Order Information

Parts Ordering Information

For the fastest service when ordering parts, telephone or FAX the *Thermo Fisher Scientific Parts Department* at the numbers given below. Your regional field service representative can also assist you with parts orders.

The recommended procedure for ordering parts is:

1. Determine the broken or faulty part.
2. Locate the part in the Parts List.
3. Find the part number(s) for the item(s) you need.
4. Before you contact *Thermo Fisher Scientific* for your parts, make sure you have the following information:
 - Machine model and serial number
 - Purchase Order number
 - Date Required
 - Preferred shipping method
 - Part number(s), description, and quantity needed.
 - Telephone or FAX:

Thermo Fisher Scientific

Customer Service Department

501 90th Ave. NW

Minneapolis, MN 55433

FAX: (763) 783-2525

Phone: (763) 783-2500

Phone: (800) 445-3503

Return Material Authorization and Repair: (763) 783-2871

Dear Customer,

Thank you for using our in-house repair service. To expedite your repair, control costs, and ensure that safety requirements are met please follow these simple steps.

1. Send in a copy of this completed form with a copy of your PO to the fax or email listed above. An RMA will not be issued without a hard copy PO on file.
2. Once an RMA has been issued, you will be sent a shipping label noting your RMA number and the address to ship the parts back to. The assigned RMA number is valid for 30 days from the date of issuance. If your part(s) is not received within 30 days, your PO will be cancelled and a new RMA will be required. All parts for repair MUST reference a valid RMA number or the part will be returned at your cost.
3. Please do not ship partial shipments. Your return must be complete. Any parts received separately will require a separate RMA and PO. Return only those products which are authorized by the RMA. Additional products that are sent without approval may be returned to you.
4. If a product is determined to be a "no defect found" then an evaluation fee of \$250.00 per part (\$500.00 per full system) sent in will be charged.
- 5.

Thank you for giving Thermo Fisher Scientific the opportunity to satisfy your service needs. You can contact me by sending an e-mail to _____ or by calling 1-800-445-3503.

Return Material Authorization (RMA) Form

Note: Thermo Fisher Scientific safety policy requires a decontamination form for any package being received into our building. Please complete the following paperwork and send it to the fax or email noted above. Failure to do so will cause delays. If the unit is not decontaminated as required, there will be a \$300.00 minimum charge.

CONTACT INFORMATION

Contact Name: _____

Phone Number: _____

Fax Number: _____

Email: _____

SHIPPING INFORMATION

Company Name: _____

Address: _____

City: _____ State: _____ Zip: _____

BILLING INFORMATION (If different from above):

Company Name: _____

Address: _____

City: _____ State: _____ Zip: _____

A/P Contact Name: _____ Phone Number: _____

Fax Number: _____ Email: _____

TAX EXEMPT: Yes No

PAYMENT INFORMATION (Choose One):

Credit Card (If you wish to pay via credit card, please call 800-227-8891, opt.2. In order to protect our customers from accidental data compromise, Thermo Fisher Scientific dba Thermo Ramsey Inc does not accept credit card numbers via email or fax.)

Purchase Order (If you wish to pay via PO, please send an official hard copy PO with this form)

PO Number: _____

Warranty (All warranties need to be pre-approved by our tech support representatives prior to an RMA being issued. If this box is checked then a tech support rep will be contacting you shortly)

PRODUCT INFORMATION:

Part number: _____ Part Description: _____

Problem description:

Part number: _____ Part Description: _____

Problem description:

Part number: _____ Part Description: _____

Problem description:

Part number: _____ Part Description: _____

Problem description:

Part number: _____ Part Description: _____

Problem description:

Part number: _____ Part Description: _____

Problem description:

DECONTAMINATION FORM

Please complete all areas of the Decontamination Declaration below.

- **Orders without a Decontamination Declaration will not be processed and the instrument will be returned to the sender via collect freight.**
- **Please send this form with a hard copy of your PO to the above email or fax number to obtain an RMA number for shipping. Retain a copy for your records.**

Please provide a specific description of your system's use:

Describe Type of Product run on your equipment:

Please describe all cleaning and/or decontamination performed:

Check all that apply:

- Out of Box Failure
 Non-Hazardous Materials only
 Hazardous Material (See Below)

Hazardous Materials:

<input type="checkbox"/> Carcinogen	<input type="checkbox"/> Bacteria	<input type="checkbox"/> Fungus	<input type="checkbox"/> Pathogen	<input type="checkbox"/> Toxic Substance
<input type="checkbox"/> Radioactive	<input type="checkbox"/> Virus	<input type="checkbox"/> Corrosive Chem. Hazard	<input type="checkbox"/> Flammable Chem. Hazard	<input type="checkbox"/> Reactive Chem. Hazard
<input type="checkbox"/> Animal/ Plant/ Mineral (Explain)			<input type="checkbox"/> Other (Explain)	
<hr/> <hr/> <hr/>			<hr/> <hr/> <hr/>	

To the best of my knowledge, this equipment is free of harmful or hazardous chemical, biological or radioactive contamination. I understand that if the equipment is found to be contaminated, regardless of the signature on this document, the equipment will be returned at my company's expense.

Signature: _____ **Title:** _____ **Date:** _____

7.3. Parts List

DTR Bulk Solids Flow Detectors:

PART NO.	STYLE	MODEL	VOLTAGE	NOTES
051685	DTR 131	CE	230 VAC	Jumper configurable for 115 VAC
055075	DTR 131	CE	24 VAC	
054851	DTR 131	CE	24 VDC	
054852	DTR 131	CE UK	230 VAC	Jumper configurable for 115 VAC; special frequency Gunn diode for UK
054921	DTR 131	FM CSA	115 VAC	Jumper configurable for 230 VAC; PG16 to 1/2 NPT adaptor included
051689	DTR 231	CE	230 VAC	Jumper configurable for 115 VAC
057665	DTR 131	CE	100 VAC	Jumper configurable for 200 VAC

Mounting Kits:

PART NO.	DESCRIPTION
054372	HF permeable Window with Flange (Sight Glass)
054854	Mounting Bracket (Adjusts for Different Angles)
054826	Pipe Standoff with Mounting Flange (90°)
054828	Pipe Standoff with Mounting Flange (45°)
058520	Replacement Plastic Plug for Pipe Standoff (90°)
054830	Replacement Plastic Plug for Pipe Standoff (45°)

7.4. Mounting Kit Drawings

Figure 7-1 Mounting Kits

