

Operating And Service Manual



Ramsey
MINI CK100
Weight Indicator

MINI CK100
Part No.: **nnnnnn**

Thermo
ELECTRON CORPORATION

Ramsey MINI CK100 Weight Indicator

This document is confidential and is the property of *Thermo Electron*. It may not be copied or reproduced in any way without the express written consent of *Thermo Electron*. This document also is an unpublished work of *Thermo Electron*. *Thermo Electron* intends to, and is maintaining the work as confidential information. *Thermo Electron* also may seek to protect this work as an unpublished copyright. In the event of either inadvertent or deliberate publication, *Thermo Electron* intends to enforce its rights to this work under the copyright laws as a published work. Those having access to this work may not copy, use, or disclose the information in this work unless expressly authorized by *Thermo Electron*.



Thermo Electron,
501 90th Avenue N.W.
Minneapolis, MN 55433 U.S.A.
Tel (763) 783-2500
Fax (763) 783-2525
<http://www.thermoelectron.com>
eng@thermoelectron.com
2003 Thermo Electron

Thermo
ELECTRON CORPORATION

Revision History

Rev.A	February 2006	Manual first released
Rev.B	April 2006	General Revision

Table of Contents

Table of Contents	i
List of Figures	iv
List of Tables	iv
About this Manualv
Who Should Use this Manual	v
Organization of the Manual.....	v
Documentation Conventions.....	vi
Safety Messages	vi
General Precaution.....	vii
Thermo Electron Warranty.....	viii
Disclaimer	ix
Chapter 1 Introduction to the MINI CK100	1-1
1.1 Unpacking and Inspection.....	1-1
1.2 Storage	1-1
1.3 Application	1-1
1.4 <i>MINI CK100</i> Functional Description.....	1-2
1.5 Configuration.....	1-4
1.6 <i>Indicator</i> General Description	1-5
1.7 Functions	1-5
1.7.1 Zero and Span Automatic Calibration	1-5
1.7.2 Zero Tracking (AZT)	1-5
1.7.3 Current Output Signal	1-5
1.8 Symbol Identification	1-6
1.9 Technical Specifications	1-7
Chapter 2 Installing the MINI CK100	2-1
2.1 Safety Precautions.....	2-1
2.2 Incoming Power	2-3
2.2.1 Critical Wiring Conditions.....	2-4
2.3 Installation	2-4
2.3.1 Mounting	2-4
2.3.2 Connecting Incoming Power 100/230(+/-10%)	2-6
2.3.3 Connecting Incoming Power 24VDC (ON REQUEST)	2-6
Chapter 3 <i>MINI CK100</i> Operation	3-1
3.1 Operator Interface.....	3-1
3.2 Front Panel	3-1
3.2.1 System Status Lights (Leds)	3-2
3.3.2 Keypad	3-2
3.2.3 LCD Graphic Display.....	3-3
3.3 Mode of Data Insert	3-3
3.3.1 Selection	3-3
3.3.2 Data Entry	3-3
3.4 Menu Displays	3-4
3.5 First Power On	3-4
3.6 Normal Power On	3-5
3.6.1 Hardware Configuration	3-5
3.7 Run Menu	3-5
3.7.1 Main Run Functions	3-5
3.7.1.1 Screen 1.....	3-5
3.7.1.2 Screen 2.....	3-6
3.7.2 Alarm Pending	3-7

3.8	Calibration.....	3-7
3.8.1	Zero Calibration Scroll.....	3-8
3.8.1.1	Manual Zero.....	3-9
3.8.2	Span Calibration Scroll.....	3-10
3.8.2.1	Auto Span.....	3-10
3.8.2.1.1	Calibration with R-CAL.....	3-10
3.8.2.1.2	Calibration with Test Weights.....	3-11
3.8.2.1.3	Span Calibration.....	3-11
3.8.2.1.4	R-CAL Factor.....	3-11
3.8.2.1.5	Recording New Span.....	3-12
3.8.2.1.6	Ending an Auto Span Procedure with Test Weights.....	3-14
3.8.2.1.7	Ending an Auto Span Procedure with R-CAL.....	3-14
3.8.2.2	Manual Span.....	3-14
3.8.2.3	Two Point Calibration.....	3-15
3.8.2.4	Usual Calibration Procedure.....	3-17
3.8.3	Linearization.....	3-18
3.9	Setup and Configuration Menu.....	3-18
3.9.1	Display.....	3-19
3.9.2	Measure Units.....	3-19
3.9.3	Weight Units.....	3-19
3.9.4	Total Units.....	3-20
3.9.5	Defining Language.....	3-20
3.9.6	Time and Date Mode (opt. COMM).....	3-20
3.9.7	Line (2) Display of Run Menu.....	3-21
3.9.8	Line (3) Display of Run Menu.....	3-21
3.9.9	Display Damping Factors.....	3-21
3.9.10	Acquiring Tare.....	3-22
3.10	Scale Data Scroll.....	3-22
3.10.1	Scale Capacity.....	3-22
3.10.2	Divisions.....	3-22
3.10.3	Defining the Load Cell(s).....	3-23
3.10.3.1	Number of Load Cells.....	3-23
3.10.3.2	Load Cell Capacity.....	3-23
3.10.3.3	Load Cell Sensitivity.....	3-23
3.10.3.4	Load Cell Resistance.....	3-24
3.10.4	Stable Weight.....	3-24
3.10.5	Stable Weight Delay.....	3-24
3.11	Calibration Data Scroll.....	3-25
3.11.1	Calibration Mode.....	3-25
3.11.1.1	Test Weight Parameters.....	3-25
3.11.1.2	R-CAL Parameters.....	3-25
3.11.2	Calibration Interval (Opt.COMM).....	3-26
3.11.3	Defining Auto Zero Tracking (AZT).....	3-27
3.12	Main Menu' 3.....	3-28
3.12.1	Changing Protection Level.....	3-28
3.12.1.1	Online Procedure for Changing Protection Level.....	3-28
3.13	Diagnostics.....	3-30
3.13.1	A/D Raw Data.....	3-30
3.13.2	Readout Load Cell mV.....	3-30
3.13.3	Change Passwords.....	3-31
3.13.4	Display Software Version.....	3-32
3.13.5	Setup Date and Time (Opt. COMM).....	3-32
3.13.6	Check Hardware Configuration.....	3-33
3.13.7	Force Cold Start.....	3-33

3.13.8	Lamp Test	3-33
3.13.9	Test Digital Inputs / Digital Outputs	3-35
3.13.10	Test Current Output (Opt. IOU).....	3-36
3.13.11	Test Communication A (Opt. COMM)	3-36
3.13.12	Test Keyboard.....	3-36
3.14	Main Menu 4	3-37
3.14.1	I/O Definition	3-37
3.14.1.1	Definition Current Output (Option I/OUT)	3-37
3.14.2	Digital Inputs Definition	3-38
3.14.3	Digital Outputs Definition.....	3-40
3.15	Alarms Definition	3-42
3.15.1	Alarm Definition Threshold 1	3-42
3.15.2	Alarm Definition Threshold 2	3-44
3.15.3	Alarm Definition Threshold 3	3-44
3.15.4	Alarm Definition Threshold 4	3-44
3.15.5	Alarms Setup.....	3-44
3.16	Ethernet	3-44
3.17	Main Menu 5 (Opt. COMM or Opt. Profibus)	3-45
3.17.1	Communication A (Opt. COMM)	3-45
3.17.2	Print (Opt. COMM)	3-47
3.17.2.1	Control	3-47
3.17.2.2	Periodical Printing.....	3-48
3.17.3	Profibus (Opt. Profibus).....	3-49
Chapter 4 MINI CK100 Maintenance		4-1
4.1	<i>Frequent Checkpoints</i>	4-1
4.2	<i>Troubleshooting</i>	4-1
4.3	<i>Alarm Messages</i>	4-1
4.3.1	Alarms List	4-2
4.4	<i>Cold Start</i>	4-4
4.5	<i>Load Cell Excitation and Signal Voltage</i>	4-4
4.6	<i>Lithium Battery Replacement</i>	4-4
4.7	<i>Disposal of Hazardous Waste</i>	4-5
4.8	<i>Cleaning Instructions</i>	4-5
Chapter 5 MINI CK100 Replacement Parts		5-1
5.1	<i>Order Informations</i>	5-1
5.2	<i>Parts List</i>	5-3
Appendix A MINI CK100 Digital Input / Output		A-1
A.1.	Mother Board Digital I/O	A-1
A.1.1.	Digital Inputs	A-1
A.1.2.	Digital Outputs	A-2
Appendix B MINI CK100 Optional Boards		A-4
B.1	Analog Out Board	A-1
B.2	Profibus Board	A-1
B.3	Comm RS232/485 Board	A-1
Appendix C Drawings		C-1

LIST of FIGURES

Figure 1-1: MINI CK100 (Panel Version)	1-2
Figure 1-2: MINI CK100 (Field Version)	1-3
Figure 2-1: MINI CK100 Overall Dimensions (Panel Version).....	2-5
Figure 2-2: MINI CK100 Overall Dimensions (Field Version).....	2-5
Figure 3-1: MINI CK100 Front Panel	3-1
Appendix Figure A-1: General Purpose Digital Inputs	A-1
Appendix Figure A-2: State Speed Input	A-2
Appendix Figure A-3: Digital Outputs	A-2
Appendix Figure A-4: State Output TTL	A-3
Appendix Figure B-1: State Current Output	B-1

LIST of TABLES

Table 1-1: Symbol Identification	1-6
Table 3-1: Alarm Conditions	3-7
Table 3-2: Protection Levels	3-28
Table 3-3: Available Logical Selections	3-39
Table 3-4: Available Logical Assignment	3-41
Table 5-1: Parts List	5-3

About this Manual

This manual provides the information you need to install, operate and maintaining of the *MINI CK100*.

Read this manual before working with the product. For personal and system safety, and for the best product performance, make sure you thoroughly understand the manual before installing or using this product.

Who Should Use this Manual

The *MINI CK100* manual is a learning resource and reference for anyone concerned with installing, operating, or maintaining *MINI CK100*.

Read this manual before working with the system. For personal and system safety, and for the best product performance, make sure you thoroughly understand the manual before installing, operating, or maintaining this machine.

Organization of the Manual

This manual is organized into five chapters and three Appendixes.

Chapter 1: Introduction to the MINI CK100 gives an overview of the device's capabilities, describes its functions, and lists its technical specifications.

Chapter 2: Installing the MINI CK100 provides information about installing the *MINI CK100* including procedures for mounting, wiring, and configuration of the instrument.

Chapter 3: MINI CK100 Operation provides an overview of the *MINI CK100* front panel, a description of how the menus operate, and information about setting up, calibrating, and operating the *MINI CK100*.

Chapter 4: MINI CK100 Maintenance provides an overview of standard maintenance associated with the *MINI CK100*.

Chapter 5: MINI CK100 Replacement Parts- provides a list of replacement parts for the *MINI CK100* and part ordering information.

Appendix A: MINI CK100 Digital Input/Output

Appendix B: MINI CK100 Optional Boards

Appendix C: MINI CK100 Drawings

Documentation Conventions

The following conventions are used in this manual to help easily identify certain types of information:

- *Italic* is used to introduce new terms and for emphasis.
- *Italic/blue* type is used for references to other sections of the manual and work as links on line and in pdf format.
- The names of setup, calibration displays, menu displays, and variables are shown in **FULL CAPITALS**.
- The names of keys on the front panel are shown in **BOLD CAPITALS**.

Safety Messages

Instructions in this manual may require special precautions to ensure the safety of the personnel performing the operations.

Please read the safety information before performing any operation preceded by this symbol.

There are two levels of safety messages: warnings and cautions. The distinction between the two is as follows:



General Precaution

Do not install, operate, or perform any maintenance procedures until you have read the safety precautions presented.



WARNING

FAILURE TO FOLLOW SAFE INSTALLATION AND SERVICING PROCEDURES COULD RESULT IN DEATH OR SERIOUS INJURY.

- MAKE SURE ONLY QUALIFIED PERSONNEL PERFORM INSTALLATION AND MAINTENANCE PROCEDURES IN ACCORDANCE WITH THE INSTRUCTIONS IN THIS MANUAL.
- ALLOW ONLY QUALIFIED ELECTRICIANS TO OPEN AND WORK IN THE ELECTRONICS CABINET, POWER SUPPLY CABINET, CONTROL CABINET, OR SWITCH BOX.
- COVERS OVER THE ELECTRONICS AND ROTATING PARTS MUST ALWAYS REMAIN IN PLACE DURING NORMAL OPERATION. REMOVE ONLY FOR MAINTENANCE, WITH THE MACHINE'S POWER OFF. REPLACE ALL COVERS BEFORE RESUMING OPERATION.
- DURING MAINTENANCE, A SAFETY TAG (NOT SUPPLIED BY THE FACOTRY) IS TO BE DISPLAYED IN THE ON/OFF SWITCH AREAS INSTRUCTING OTHERS NOT TO OPERATE THE UNIT (ANSI:B157.1).



WARNING

HIGH VOLTAGE THAT MAY BE PRESENT ON LEADS COULD CAUSE ELECTRICAL SHOCK.

- ALL SWITCHES MUST BE OFF WHEN CHECKING INPUT AC ELECTRICAL CONNECTIONS, REMOVING OR INSERTING PRINTED CIRCUIT BOARDS, OR ATTACHING VOLTMETERS TO THE SYSTEM.
- USE EXTREME CAUTION WHEN TESTING IN, ON, OR AROUND THE ELECTRONICS CABINET, PC BOARDS, OR MODULES. THERE ARE VOLTAGES 100 V OR 230 V IN THESE AREAS.



WARNING

USE ONLY THE PROCEDURES AND NEW PARTS SPECIFICALLY REFERENCED IN THIS MANUAL TO ENSURE SPECIFICATION PERFORMANCE AND CERTIFICATION COMPLIANCE. UNAUTHORIZED PROCEDURES OR PARTS CAN RENDER THE INSTRUMENT DANGEROUS TO LIFE, LIMB, OR PROPERTY.

 WARNING
KEEP HANDS AND CLOTHING AWAY FROM ALL MOVING OR ROTATING PARTS.

 WARNING
DO NOT PLACE OR STORE OBJECTS OF ANY KIND ON THE MACHINE.

 WARNING
THIS MACHINE SHOULD NOT BE OPERATED AT MORE THAN THE PRODUCTION RATE STATED ON YOUR EQUIPMENT SPECIFICATION SHEET OR USED IN APPLICATIONS OTHER THAN THOSE STATED IN THE ORIGINAL ORDER.

Thermo Electron Warranty

The seller agrees, represents, and warrants that the equipment delivered hereunder shall be free from defects in material and workmanship. Such warranty shall not apply to accessories, parts, or material purchased by the seller unless they are manufactured pursuant to seller's design, but shall apply to the workmanship incorporated in the installation of such items in the complete equipment. To the extent purchased parts or accessories are covered by the manufacturer's warranty, seller shall extend such warranty to buyer.

Seller's obligation under said warranty is conditioned upon the return of the defective equipment, transportation charges prepaid, to the seller's factory in Minneapolis, Minnesota, and the submission of reasonable proof to seller prior to return of the equipment that the defect is due to a matter embraced within seller's warranty hereunder. Any such defect in material and workmanship shall be presented to seller as soon as such alleged errors or defects are discovered by purchaser and seller is given opportunity to investigate and correct alleged errors or defects and in all cases, buyer must have notified seller thereof within one (1) year after delivery, or one (1) year after installation if the installation was accomplished by the seller.

Said warranty shall not apply if the equipment shall not have been operated and maintained in accordance with seller's written instructions applicable to such equipment, or if such equipment shall have been repaired or altered or modified without seller's approval; provided, however, that the foregoing limitation of warranty insofar as it relates to repairs, alterations, or modifications, shall not be applicable to routine preventive and corrective maintenance which normally occur in the operation of the equipment.

“EXCEPT FOR THOSE WARRANTIES SPECIFICALLY CONTAINED HEREIN, SELLER DISCLAIMS ANY AND ALL WARRANTIES WITH RESPECT TO THE EQUIPMENT DELIVERED HEREUNDER, INCLUDING THE IMPLIED WARRANTIES OF MERCHANTABILITY AND FITNESS FOR USE. THE SOLE LIABILITY OF SELLER ARISING OUT OF THE WARRANTY CONTAINED HEREIN SHALL BE EXCLUSIVELY LIMITED TO BREACH OF THOSE WARRANTIES. THE SOLE AND EXCLUSIVE REMEDY FOR BREACH OF THE WARRANTIES SET OUT ABOVE SHALL BE LIMITED TO THE REPAIR OR REPLACEMENT OF ANY DEFECTIVE ACCESSORY, PART OR MATERIAL WITH A SIMILAR ITEM FREE FROM DEFECT, AND THE CORRECTION OF ANY DEFECT IN WORKMANSHIP. IN NO EVENT SHALL SELLER BE LIABLE FOR ANY INCIDENTAL OR CONSEQUENTIAL DAMAGES.”

Purchaser agrees to underwrite the cost of any labor required for replacement; including time, travel, and living expenses of *Thermo Electron Field Service* Engineer at closest factory base.

Disclaimer

Though the information provided herein is believed to be accurate, be advised that the information contained herein is *not* a guarantee for satisfactory results. Specifically, this information is neither a warranty nor guarantee, expressed or implied, regarding performance, merchantability, fitness, or any other matter with respect to the products, and recommendation for use of the product/process information in conflict with any patent. Please note that *Thermo Electron* reserves the right to change and/or improve the product design and specifications without notice.

Chapter 1

Introduction to the MINI CK100

This instruction manual contains information on the installation, operation, calibration, and maintenance of the *MINI CK100 Weight Indicator*.

1.1 Unpacking and Inspection

The *MINI CK100* has been properly packaged for shipment and storage, when necessary.

Inspect all packages for damage before opening; sometimes the carrier may be responsible for shipping damage.

1.2 Storage

The *MINI CK100* can be safely stored, with cover, latches secured and hole plugs installed, between -40° to +158° F (-40° to +70° C). The units should be protected against moisture.

1.3 Application

The *MINI CK100* is a bus-based microcomputer driven instrument used for static weighing of bulk materials. Common application are C-Level, Unitrain Load-out and check weigh bins for in-line conveyor belt scale calibration , weighing platform .

The Static Weight System includes the following principal components :

1. LOAD RECEIVING ELEMENT

That element of a scale designed to receive the load to be weighed (for example: platform, deck, rail, hopper, platter, plate, or scoop). See the installation drawing for specific type of load receiving element supplied with your system.

2. LOAD CELL SYSTEM

Thermo Ramsey uses three load cell systems depending on the application. They are tension, compression, and shear beam.

3. STATIC WEIGHT INDICATOR MINI CK100

Static weight indicator is designed to convert force signals from 1 to 6 strain gauge load cells to an accurate stable signal for local and remote weight indication.

The remote weight indication is available with an optional board for analog signal, serial communication or bus.

1.4 MINI CK100 Functional Description

The *MINI CK100* is available with the following configuration hardware and software.

- Menu driven scroll entries on a four line display.
- Five LED status indicators.
- Automatic zero and span calibration.
- Auto zero Tracking.
- Several software options that may be turned on by keyboard entry or installing optional board.
- Optically coupled digital inputs and outputs.
- Alarms and failure detection.
- Ethernet Line
 - (OPTIONAL) Communication : RS232C, RS485, Profibus
 - (OPTIONAL) 20mA Current Loop passive.

Figure 1-1: *MINI CK100 (Panel Version)*



Figure 1-2: MINI CK100 (Field Version)



1.5 Configuration

The standard configuration of the *MINI CK100* includes the following:

- Single channel load cell input to a max of 6 load cells
- 2 programmable digital inputs
- 1 programmable digital output
- 4 optically digital outputs TTL (programmables)
- 1 Ethernet Line
- 1 slot for insert the following optional board :
 1. Current Output Board (20mA Current Loop passive)
 2. Serial Communication Board
 3. Profibus-DP Board

1.6 Indicator General Description

The *MINI CK100* is designed for static weighing systems..

The base functions are located on the instrument software. Function accessories are activated when the correspondent hardware are mounted , or after activation from keyboard by operator. Instrument parameters programming is executed from keyboard. A menu driven allows the operator to access all setup, test and calibration parameters.

Static weight indicator is designed to convert force signals from max 6 strain gauge load cells (350ohm).

The process variables displayed can be damped by a programmable factor.

The *Indicator* has built-in troubleshooting capabilities. A number of possible internal alarms are automatically detected and screen messages are displayed. The alarms can be acknowledged and by keyboard or remote digital input is possible to clear the alarms.

The alarms can be programmed and defined to be :

ALARM , SHUT DOWN process or NONE (ignored).

The front panel shows the led status (Alarm) illuminated .

Are availables digital output for the following conditions:

- Cumulative Alarms
- Cumulative Shut Down

With the serial communication (optional) is possible by command to have a periodical and instantaneous printing format on printer of data sistem. Is available the clock function maintained by lithium battery.

Are availables three type of communications :

- *Ethernet Modbus TCP (Standard)* – The protocol allows a remote intelligent device to read and write data of the registers. During the communication activity, the *MINI CK100* will always act as slave, meaning it will respond to a request from a master device on the line, but will never attempt to send messages out.
- *Serial Communication (Optional)* – The protocol allows a remote intelligent device to read and write data of the registers. During the communication activity, the *MINI CK100* will always act as slave, meaning it will respond to a request from a master device on the line, but will never attempt to send messages out.
- *Profibus DP (Optional)* – The protocol allows a remote intelligent device to read and write data of the registers. During the communication activity, the *MINI CK100* will always act as slave, meaning it will respond to a request from a master device on the line, but will never attempt to send messages out.

1.7 Functions

This section provides the information about functions of the *MINI CK100*.

1.7.1 Zero and Span Automatic Calibration

Electronic Calibration (R-Cal) – Allows the calibration without application test weights. The electronic calibration controls the instrument with load cell, the program inserts a precision resistance (in parallel to load cell strain gauge) that simulates a weight variation. The calibration constant is obtained with reference of load cell and scale data.

Calibration with Test Weights – Is necessary the installation of test weights on the scale.

1.7.2 Zero Tracking (AZT)

This function is performed executing continuous periodical zeroing actions, in order to compensate the zero variations due to deposit of material or similar causes.

If for a selected time the instrument has a weight value different to zero, included a activation value (Activation Range) selected, the AZT function provides executing zeroing actions.

The max value for autozero tracking is selected with Activation Range.

1.7.3 Current Output Signal (Optional)

A current output is available (0-20/4-20 mA). The output range and the function are selected by keyboard. The functions available are the following :





- Gross Weight
- Net Weight
- Tare
- Peak

The current output has a filter and camping that can be selected.

1.8 Symbol Identification

Table 1-1 describes the symbols used in this manual.

Table 1-1: Symbol Identification

Symbol	Description
	ALTERNATING CURRENT
	EARTH (GROUND) TERMINAL
	PROTECTIVE CONDUCTOR TERMINAL
	CAUTION, RISK OF ELECTRIC SHOCK
	CAUTION (REFER TO ACCOMPANYING DOCUMENTS)

1.9 Technical Specifications

Enclosure

Panel Version

Dimensions: 96 x 96 x 124mm

Frontal Protection IP65 Enclosure IP00

Field Version

Dimensions: 300 x 250 x 160mm

Reinforced Fiberglass Housing Protection IP65

Environmental Conditions

Mounting

Should be mounted as close to the load cells as possible without being exposed to excessive heat or moisture

Temperature (Ambient)

Storage: -40° +70° C

Operating: -10° +50° C

Relative Humidity

Up to 95%, non-condensing

Pollution Degree

2

Altitude

Up to 2000mt.

Power Requirements

Nominal Voltage (VAC)

100/230 VAC

Nominal Frequency

50/60 Hz

Fusing

0.4 Amp SB Type C

Power Consumption

26 VA Max

Nominal Voltage (VDC) on Request

24 VDC

Fusing

0.4 Amp SB Type C

Power Consumption

26 VA Max

Maximum Non-Destructive Input Voltage

From 100 to 230 VAC +10%

Over Voltage Category

Category II

DC Power Supply

Auxiliary Power Supply Output

Output Voltage: 24 VDC

Isolation: 500 Volt

Output ripple: 200 mV peak to peak typical

Output Current: 400 mA max.

Short Circuit Protection

Load Cell (Weight)

Load cell input circuits

Number: Up to six (6) 350-ohm load cells in parallel.
Cable distance 200 ft or less (3000 ft with sense)

Sensitivity: 0.5mV/V to 3.5 mV/V (keyboard selectable)

Input Impedance: 100 k-ohm minimum

Maximum Usable Signal: 114% of 3mV/V

Displayed A/D counts (3mV/V):112368

Isolation: Non-isolated

Max non-destructive input voltage: ± 6 V relative to ground

Load Cell Cable Shield: Connected to earth ground

Load Cell Excitation Power Supply

10 VDC $\pm 10\%$, 120 mA

Minimum load impedance (operating) 58 ohms

Output short circuit, 1.5 A maximum

Excitation - Sense Circuit

6 Wire System; cable distance over 200 ft. (not to exceed 3000 ft.).

Nominal input voltage: ± 5 VDC (10 volts)

Input impedance: 100 k-ohm minimum

Jumper selectable: Local or remote sense

Digital Input (N°1 SPU + N°1 Relay Contact)

(1) High Frequency Input Optocoupled (DC)

(1) Optocoupled

Internal Power Supply for dry contact input

Power Supply : +24V external

Cable Length : 2500m section. 1.5 mm² (150 Ohm max.)

Digital Output

(4) Digital Output (TTL) 40mA

used with positive or negative logic

mounted on socket for easy replacement

(1) Output Optocoupled (interface with RELAY)

Interface with TTL, CMOS, RELAY

Technical Data : 24 VDC, 40mA DC max.

Current Output (Option)

1 Current Output (20mA Current Loop Passive)

Output range: User selectable 0 – 20 mA or 4-20 mA, representing 0 to 100% variable.

Resistive load: 800 ohm max. Loop

Capacitive load: No limit

Communication

Ethernet (Standard)

10 Base T

Seriale Interface (Optional)

Type: Conforms to RS-232C, RS-485; supports 2 and 4 wire multi-drop.

Interfacing: RS-485 supports 2-wire or 4-wire multi-drop networking;

RS 232 C provides support for modem.

Data rate: 110 to 19200, operator selectable from the keyboard.

Data Format: Asynchronous, bit-serial, selectable parity, data length, and stop bits.

Optical Isolation: 250 VRMS max.

Input Voltage: ±30 Vdc max. (RS-232C)

±15/-10 Vdc max. (RS-485)

Cable Length: 50 feet max. (RS-232C)

4000 feet max (Rs-485)

Profibus DP (Optional)

Type: Profibus DP Slave C (Siemens SPC3 Controller).

Optical Isolation: 250 VRMS max.

Input Voltage: +5VDC

Baud Rate: 9600 – 12 Mbps

Chapter 2

Installing the MINI CK100

This chapter describes the *Static Weight Indicator* installation procedure, hardware configuration, and initial programming. Initial programming is a machine directed procedure prompting the operator to enter required conveyor and belt scale parameters. After all parameters have been entered, the *Static Weight Indicator* performs an unassisted zero and span calibration.

2.1 Safety Precautions



CAUTION

DO NOT INSTALL, OPERATE, OR PERFORM ANY MAINTENANCE PROCEDURES UNTIL YOU HAVE READ THE SAFETY PRECAUTIONS THAT FOLLOW.



CAUTION

DO NOT CONNECT POWER TO THE ELECTRONICS OR TURN ON THE UNIT UNTIL YOU HAVE READ AND UNDERSTOOD THIS ENTIRE MANUAL. THE PRECAUTIONS AND PROCEDURES PRESENTED IN THIS MANUAL MUST BE FOLLOWED CAREFULLY IN ORDER TO PREVENT EQUIPMENT DAMAGE AND PROTECT THE OPERATOR.

**WARNING**

ALL SWITCHES (SUCH AS CONTROL OR POWER) MUST BE OFF WHEN CHECKING INPUT AC ELECTRICAL CONNECTIONS, REMOVING OR INSERTING PRINTED CIRCUIT BOARDS, OR ATTACHING VOLT METERS TO THE SYSTEM.

INCOMING VOLTAGES MUST BE CHECKED WITH A VOLTMETER BEFORE BEING CONNECTED TO THE ELECTRONICS.

**WARNING**

EXTREME CAUTION MUST BE USED IN TESTING IN, ON, OR AROUND THE ELECTRONICS, PC BOARDS, OR MODULES. THERE ARE VOLTAGES OF 100 V OR 230 V IN THESE AREAS. AVOID HIGH VOLTAGE AND STATIC ELECTRICITY AROUND THE PRINTED CIRCUIT BOARDS.

**WARNING**

MAINTENANCE PROCEDURES SHOULD BE PERFORMED ONLY BY QUALIFIED SERVICE PERSONNEL AND IN ACCORDANCE WITH PROCEDURES/INSTRUCTIONS GIVEN IN THIS MANUAL.

**WARNING**

DURING MAINTENANCE, A SAFETY TAG (NOT SUPPLIED BY THERMO ELECTRON) SHOULD BE DISPLAYED IN THE ON/OFF SWITCH AREAS AS A PRECAUTION INSTRUCTING OTHERS NOT TO OPERATE THE UNIT.

**WARNING**

ONLY QUALIFIED SERVICE TECHNICIANS SHOULD BE ALLOWED TO OPEN AND WORK IN THE ELECTRONICS, POWER SUPPLY, CONTROL, OR SWITCH BOXES.



WARNING

THIS EQUIPMENT SHOULD NOT BE OPERATED OR UTILIZED IN APPLICATIONS OTHER THAN THOSE STATED IN THE ORIGINAL ORDER.

TO ADAPT PRODUCTION RATES OR APPLICATIONS, CONSULT *THERMO ELECTRON* PRODUCTS *CUSTOMER SERVICE* FOR RECOMMENDATIONS.



WARNING

ALL PANELS COVERING THE ELECTRONICS MUST BE IN PLACE AND TIGHT BEFORE WASH DOWN PROCEDURES. DAMAGE TO THE ELECTRONICS COULD RESULT FROM WATER, MOISTURE, OR CONTAMINATION IN THE ELECTRONICS HOUSING.

2.2 Incoming Power



CAUTION

VERIFY THAT THE INPUT VOLTAGE IS CORRECT WITH AN AC/DC VOLTMETER BEFORE YOU CONNECT IT TO THE *INSTRUMENT*.



CAUTION

EARTH GROUND MUST BE PROVIDED TO THE *INSTRUMENT*. DO NOT USE CONDUIT TO PROVIDE THIS GROUND.



CAUTION

A READILY ACCESSIBLE DISCONNECT DEVICE SHALL BE INCORPORATED IN THE FIELD WIRING. THIS DISCONNECT DEVICE SHOULD BE IN EASY REACH OF THE OPERATOR AND IT MUST BE MARKED AS THE DISCONNECTING DEVICE FOR THE EQUIPMENT.

2.2.1 Critical Wiring Condition

1. Ensure power is off at the mains
2. Do not route load cell and signal cables in the same conduit with power cables or any large source of electrical noise.
3. Earth ground all enclosures and conduits. A ground connection between all conduits is required.
4. Connect the shields *ONLY* where shown.
5. Check that all wires are tight in their connections.
6. Never use a “megger” to check the wiring.
7. A readily accessible disconnect device (Max 10A) shall be incorporated in the field wiring. This disconnect should be in easy reach of the operator and it must be marked as the disconnecting device for the equipment.
8. All conduits should enter the bottom of the enclosure. Do not run conduit through the top or sides of the enclosure.



2.3 Installation

The *MINI CK100* is available for mounting in a control panel or for field mounting.

2.3.1 Mounting

The mounting place must be carefully selected, avoiding places where there are vibrations, high temperature or humidity.

The *MINI CK100 (Panel Version)* is supplied for mounting on a covered front panel with any inclination compared to the horizontal position.

The *MINI CK100 (Field Version)* is supplied for mounting in open air. It is suggested a mounting in a protected position against rain about, in a place with strong vibrations, it is better to provide a mounting using non vibrating devices.

The instrument must be positioned with a suitable height in order to easily read the display and conveniently access to the key board.

Figure 2-1: *MINI CK100* Overall Dimensions (Panel Version)

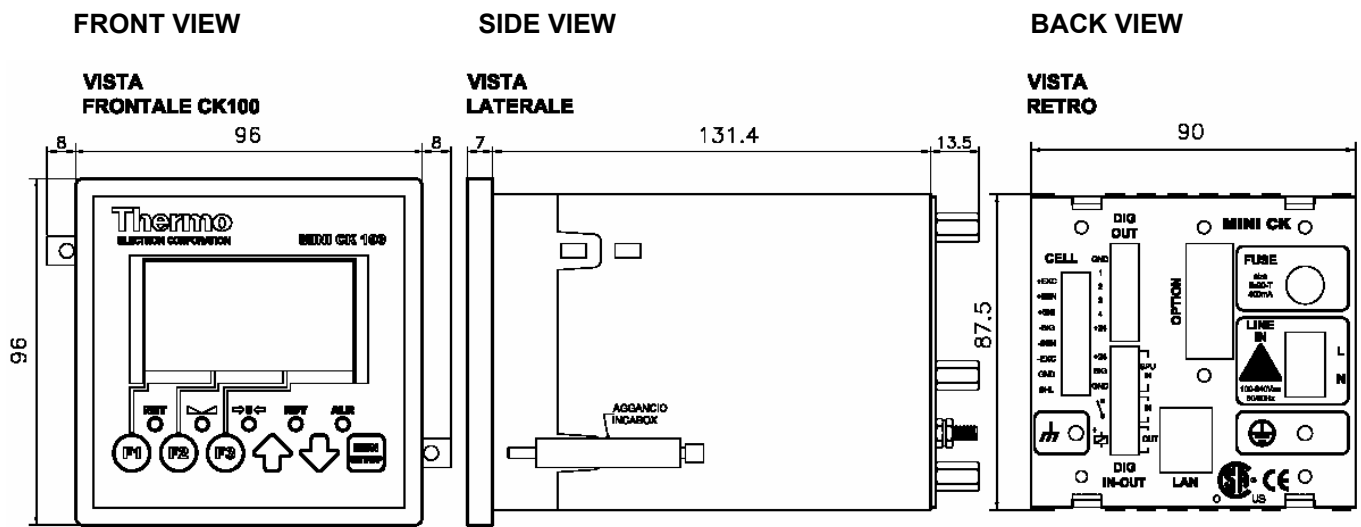
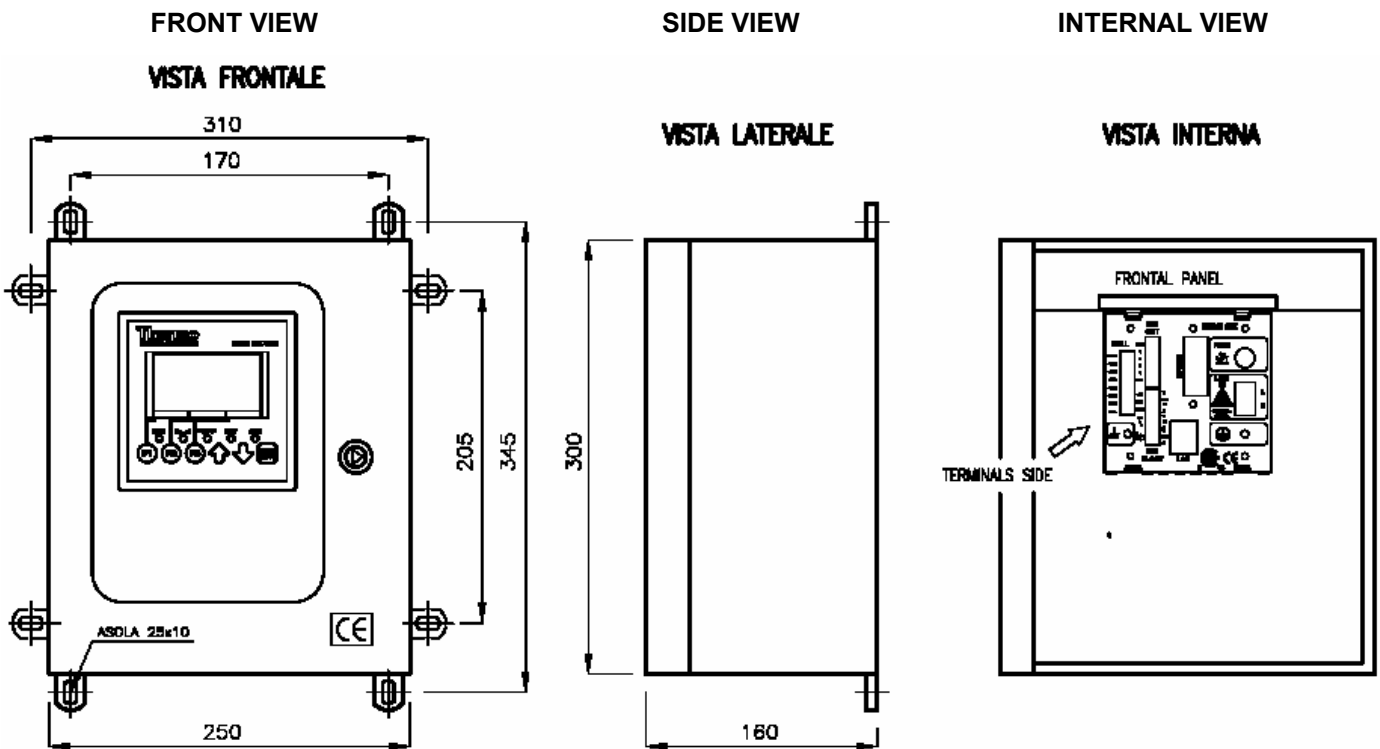

Figure 2-2: *MINI CK100* Overall Dimensions (Field Version)



2.3.2 Connecting Incoming Power 100/230 VAC (+/-10%)

To connect incoming power use the following procedure.

- For input power use cable 14AWG
- Wire the safety ground terminal locate on the backside of the enclosure (Protection GND PE).
- Wire the HOT to terminal labelled of Terminal L on the Power Input Terminal.

Wire the NEUTRAL to the terminal labeled of Terminal N on the Power Input Terminal.

2.3.3 Connecting Incoming Power 24VDC (ON REQUEST)

To connect incoming power use the following procedure.

- For input power use cable 14AWG
- Wire the safety ground terminal locate on the backside of the enclosure (Protection GND PE).
- Wire the POSITIVE (+24VDC) to Terminal (+) on the Power Input Terminal.
- Wire the NEGATIVE (-24VDC) to Terminal (-) on the Power Input Terminal.

Chapter 3

MINI CK100 Operation

The *MINI CK100* is capable of accurate weighing, provided it is installed, calibrated, operated, and maintained in complete accordance with the instructions contained in this manual.

3.1 Operator Interface

This section contains information on set up and operation of the *MINI CK100*. Operator interface is composed of keypad, status indicators (led) and display.

Figure 3-1: *MINI CK100* Front Panel

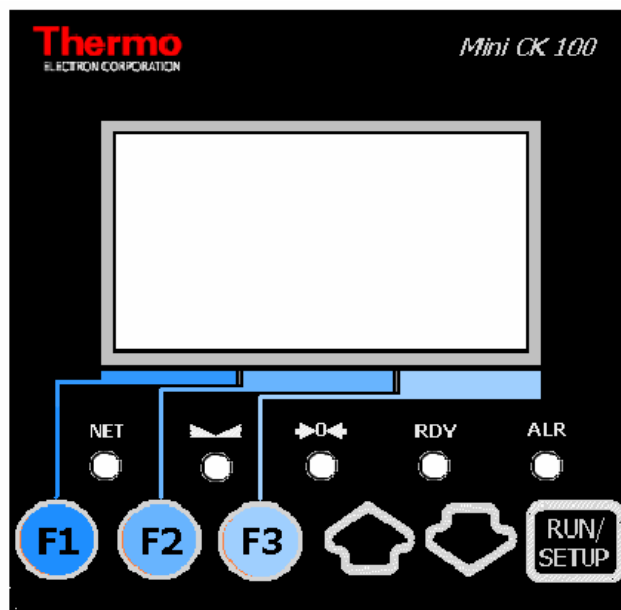

3.2 Front Panel

The *MINI CK100* Front Panel contains:

- 5 System Status Lights (Leds).
- LCD Graphic Display
- Keypad

3.2.1 System Status Lights (Leds)

The five red status indicators show the status of the *Static Weight Indicator*

NET

ON indicates when a net weight is displayed, in other words, it is on when a tare weight has been acquired.

STABLE WEIGHT

The stable weight condition is determined on the basis of two parameters : motion band and motion delay.

Motion band defines a range in which the weight is stable, and motion delay defines the time the weight should stay in the range before stable weight indications turns on.

ZERO WEIGHT

Net weight is considered zero when its value is between +/- 0.5 scale division.

The weight must stay in this range for 2 seconds after the weight becomes stable zero weight indication is turned on.

ALARM

Alarm indication flashes if an alarm is pending, either the alarm is NEW or has been ACKNOWLEDGED.

READY

Ready indication turns on if the scale is calibrated (zero and span calibration complete) and no SHUT DOWN conditions are active.

3.2.2 Keypad

The keypad is comprised of pad touch keys consisting of the following

F1	Function Key 1
F2	Function Key 2
F3	Function Key 3
^	Scroll Up
v	Scroll Down
RUN / SETUP	Selection mode RUN / SETUP

On the interface scroll, the fourth display row is composed of three sections. Each section shows the action of the corresponding key.

Baud Rate > 9600 <		
<F1 Descr.>	<F2 Descr.>	<F3 Descr.>

The Scroll Keys (UP or DOWN) allow change the page displayed.

The RUN/SETUP Key allows selection of the menu modes. RUN is the operative mode with indication of variables and status scale. SETUP is the configuration and calibration mode of the instrument.

3.2.3 LCD Graphic Display

The display is composed of 4 rows (20 alphanumeric characters each row).

Two main modes displayed : RUN and SETUP. The following section describes the menus..

3.3 Mode of Data Insert

Are available two mode for to insert data by keypad : SELECTION , DATA ENTRY

3.3.1 Selection

Allows to select the value from a list available. See the following example :

Baud Rate > 9600 <		
CHOICE	ENTER	

CHOICE scroll the list of the value availables

ENTER allows the selection and the confirm of the value displayed.

The data into '> <' is the value active for the selection.

3.3.2 Data Entry

Is necessary for to insert a numerical value.

MAX RATE 500.00 KG		
ENTER		

ENTER has a double function:

- Press the first time allows the start of the data entry procedure.
- Press the second time confirms the data entry and finish the procedure.

In the data entry procedure the number that must be modified is flashing. SCROLL UP / SCROLL DOWN keys allow to modify the value. The F2 and F3 keys (are activated from the first press of ENTER key) allow the scroll to former or following number.

MAX RATE 500.00 KG		
ENTER	<	>

In the same mode is possible to insert of negative value.

OFFSET +10.00 KG		
ENTER	<	>

3.4 Menu Displays

The interface is a menu driver machine that allows the operator to access all setup, test and calibration parameters.

The following table shows the menu structure.

The functions highlighted are optional and are available only if the corresponding option hardware or software has been installed.

Mode	Menu	F1	F2	F3
SETUP				
	MAIN MENU 1	ZERO CAL	SPAN CAL	LINEAR
	MAIN MENU 2	DISPLAY	SCALE DATA	CALIB DATA
	MAIN MENU 3	PROTECTION	DIAG	TEST
	MAIN MENU 4	I/O DEF	DEF. ALLARM	NET
	MAIN MENU 5	COMM A	PRINT	PROFIBUS
RUN				
	SCREEN 1	S/R TARE		ALARM
	SCREEN 2	RESET	ACQ	ALARM

The following keys allow the scroll through the menus :

- Press **RUN/SETUP** key to change Mode
- Press **DOWN SCROLL** key to advance through the menus.
- Press **UP SCROLL** key to return to the previous item displayed.
- Press **F1 / F2 / F3** key to access sub-menus or to activate the function displayed.

If the *MINI CK100* is password protected, the appropriate password must be entered prior to making changes or performing routine calibration. Menus may be viewed without entering a password, but no entries are allowed unless the password is entered.

3.5 First Power On

When power is first applied to the *MINI CK100*, the system steps the operator through menus and options that bring the system to a weighing state. After the initial programming the instrument executes a simulate scale calibration then the system is ready for the weighing.

For to obtain a better accuracy is necessary a calibration with test weights

The data request are available on menu Display, Scale Data, Calibration Data.

Section 3.9, 3.10 and 3.11 of this manual.

3.6 Normal Power On

When the *MINI CK100* is powered on after initial programming, the RUN MENU 1 is displayed unless the hardware configuration has been changed.

3.6.1 Hardware Configuration

If the hardware configuration detected at power on differs from the one recorded in memory, the following screen displays. This only happens if a circuit board has been added or removed during power off, or a board has failed.



--CONFIG CHANGED
Acuire new
configuration
OK

This screen disappears after 10 seconds if the question is not answered or if press a key.

If a board is removed or added must be necessary reply the instrument configuration.

3.7 Run Menu

When the *Static Weight Indicator* is normally powered on after initial programming, the RUN (RUN MENU 1) is displayed. The RUN menu can always be accessed by pressing the **RUN** key on the front panel.

3.7.1 Main Run Functions

Is composed of two screens. Press UP or DOWN keys for scroll.

3.7.1.1 Screen 1

The usual screen is the following:

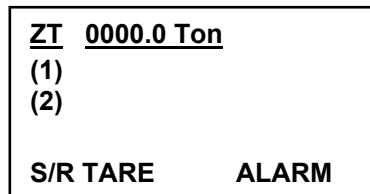

ZT 0000.0 Ton
(1)
(2)
S/R TARE ALARM

The first line always displays the actual NET WEIGHT. A “Z” appears on the left side if the “Auto zero tracking” option is enabled and the scale is unloaded. The load must stay low during the cycle; otherwise, auto zero is aborted.

A “T” appears if tare weight has been acquired. The second (1) and third (2) lines are by default blank, but can be programmed to show :

2. The tare weight
3. The actual gross weight
4. The peak weight
5. The reset total value
6. The master total value
7. Date and time
8. A bar graph indicator

F3 key allows list active alarms indication.

F1 key SET / RESET TARE

Il tasto F2 (2) allows:

RESET – If peak weight is selected, it reset the Peak Value selected.

PRINT – If active the option , allows weight and total print.

3.7.1.2 Screen 2

This menu screens the totals. Usual indication is the following :

ZT <u>0000.0 Ton</u>
MTot <u>0000.0 Ton</u>
RTot <u>0000.0 Ton</u>
RESET ACQ ALARM

The first line displays as MENU RUN SCREEN 1

Second and third line displays Master Total and Reset Total value.

ACQ key allows to add the actual weight value to register of the totals..

RESET key allows the Reset Total. Is request confirm:

Confirm the clear RESET TOTAL ?
YES NO

Press **YES** to clear the total, press **NO** to skip clearing.

3.7.2 Alarm Pending

The message **ALARM** displays in the right of the screen if an alarm is pendine. The red alarm LED also flashes.

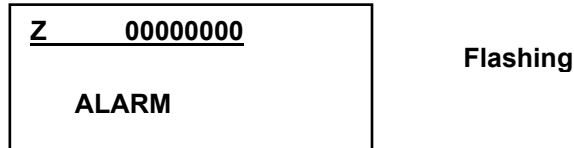

The following menu displays after pressing **ALARM**

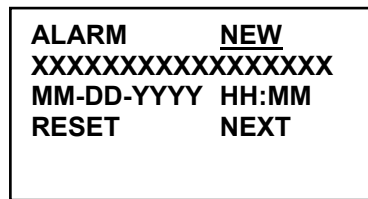

The keyword “NEW” indicates an alarm that has not been acknowledged yet. When the operator presses the RESET key to clear the alarm. The alarm disappears only if the reason that caused the alarm to occur does not exist any more. If the alarm is still pending, the keyword “ACK” is displayed instead of “NEW”.

The third line shows the date and time (Only if available print option).

The NEXT key is used to scroll between the pending alarms. The string “XXXXXXXXXXXXXXXXXXXX” stands for one of the following alarm conditions.

Pressing RUN returns to Main RUN Menu.

Table 3-1: Alarm Conditions

1 – Clock Fail	11 – Calibration Interruption
2 – Load Cell Fail	12 – Calibration TimeB#
3 – RAM Fail	13 – External Alarm
4- ROM Fail	14 – AZT Limit
5– Threshold #1	15 – Math Error
6– Threshold #2	16 – Printer Error
7– Threshold #3	17 – Communication Error
8– Threshold #4	
9- Warm Start	
10 – Cold Start	

Refer to [Chapter 4](#) for more information.

3.8 Calibration

The **MAIN MENU 1** contain the Calibration Menu. The MENU 1 is selected by pressing **SETUP**. Desired calibration scrolls are selected by pressing the soft keys directly below the desired scroll.

```
-- MENU 1 --  
Premi MENU for more  
ZERO SPAN LINEAR  
CAL CAL
```

3.8.1 Zero Calibration Scroll

The Zero calibration is implemented as a machine directed procedure

1. Press **ZERO CALIB**, the next screen is shown:

```
-- ZERO CAL --  
Empty scale, then press  
START  
  
START MANUAL
```

During Auto Zero procedure the scale must be kept empty. A complete zeroing procedure requires 10 seconds, but can be reduced by pressing **END** in the next scroll.

Press **MANUAL** for next functio 2

Pressing **RUN** returns to menu **RUN**

2. Press **START**, the next screen is shown :

```
AUTO ZEROING  
Time remaining 0000  
Gross: 000.0 kg  
END ABORT
```

During *Auto Zero*, weight resolution is 10 times higher than normal. The number of seconds in line 2 corresponds to the time remaining for completing the test.

When zero is reached or END is pressed, the system displays the following screen :

AUTO ZERO COMPLETE
Error \pm <u>000.00%</u>
Change zero?
YES NO

The word COMPLETE is flashing.

The percentage of error is related to the scale capacity.

Press **NO** returns **MENU 1** without zero changed..

Press **YES** for to modify the zero with the new value. The next screen is shown :

ZERO CHANGED
New zero <u>00000</u>
Old zero <u>00000</u>
RUN MENU

Press **MENU** for reply zero automatic calibration.

Pressing **RUN** returns to menu **RUN**

3.8.1.1 Manual Zero

The *Manual Zero* procedure allows the operator to directly enter the zero constant if known.

Use **ENTER** key for to confirm the new value.

-MANUAL ZERO-
Gross <u>000.0</u>
Zero <u>00000</u>
ENTER EXIT (ADV)

Password:Operator

Default: 40000 **Min:** 0 **Max:** 120000

The ADV key is only displayed if Auto Zero Tracking optional function is enable. The AZT function accurately tracks the zero of each scale by calculating an additional zero constant. The portion of zero due to AZT is not incorporated in the zero constant, but is shown separately.

When ADV is pressed, the system scrolls between Zero and AZT.

- ZERO CORRECTION-		
AZT	±000000	
AZT %	±000000	
ENTER	EXIT	ADV

When is displayed AZT value, with ENTER key is possible to insert AZT value in the zero constant, then are displayed the AZT number and the percent. (%) of difference about the previous zero value.

3.8.2 Span Calibration Scroll

The span calibration can be done in two different ways:

- *R-Cal*
- *Test Weights or Two Point Calibration*

The *Indicator* allows the operator to select which one of the two methods to be used. The selection is made in **MENU 2, CAL DATA**.

Then to return to MENU 1 for Span Calibration.

3.8.2.1 Auto Span

3.8.2.1.1 Calibration with R-Cal

Use the following procedure for *Calibration with R-CAL*:

1. Press key function **CAL SPAN**

The following screen displays:

AUTO SPAN R CAL	
Empty scale, Then press	
START	
START	MANUAL

When **START** is pressed, the Rcal relay energizes. A half second delay occurs after START for the weight to stabilize, then begin the AutoSpan.

NOTE : The operator must be insure that the scale is empty before pressing start.

3.8.2.1.2 Calibration with Test Weights

Use the following procedure for to start Test Weights calibration.

1. Apply Test Weights.
2. Press **CAL SPAN**

The following screen displays:

AUTO SPAN WEIGHTS Apply Weights then press START. START MANUAL
--

Password: Operator

3.8.2.1.3 Span Calibration

Whichever method has been used to start automatic span calibration, after START is pressed, the following screen is displayed :

AUTOSPANNING Time remaining 0000 Gross 0000.0 kg END ABORT
--

During Auto Span, the weight resolution is 10 times higher than normal. The entire function takes 60 seconds to be completed, remaining time is displayed in line 2. The END key can be used to conclude the function in less time.

3.8.2.1.4 RCAL Factor

This part of the procedure is only executed if a calibration with test weights was done before, and if R-CAL has not been factored yet.

It is very important to understand that **when this procedure is executed, the system will not alter the span**. The system assumes the span is set correctly based on a test weight calibration. The system acquires the R-CAL FACTOR. The factored R-CAL can then be used to check the span between test weight calibrations.

 CAUTION
SPAN SHOULD ONLY BE CHANGED BASED ON A TEST WEIGHT CALIBRATION

When is end the procedure the following screen is displsyed:

AUTO SPAN COMPLETE Error <u>+/- 00.00</u> % Unifactorred Calcon EXIT FACTOR REPEAT

The word **COMPLETE** is flashing.

The possible selections are: **EXIT**, **REPEAT**, and **FACTOR**.

If **EXIT** is pressed, the system acknowledges that the R-CAL factor is not used. The effect of this is that the system does not ask for a factor any more for this calibration method unless a manual span entry is done. By pressing **EXIT**, the operator tells the system that he does not want to use factors, but wants to use the test results for changing the span number.

After **EXIT** is pressed, go to point Section 3.8.2.1.5.

If **REPEAT** is pressed, to return Section 3.8.2.1.3.

If **FACTOR** is pressed, the following screen is displayed :

```
FACTORING XXX
New factor: 000.00 %
Change factor ?
YES      NO
```

XXX = R-Cal,

Press **NO** – The old R-CAL factor is not modified

Press **YES** – The following screen is displayed :

```
FACTORING XXX
Old Factor.: 000.00 %
New Factor : 000.00 %
RUN      REPEAT
```

XXX = R-Cal,

If **REPEAT** is pressed, go precedent section.

If **RUN** is pressed, returns to menu **RUN**.

After an Auto Span with R-CAL, when **RUN** is pressed, the R-CAL relay is de-energized and the display is steady for three seconds.

3.8.2.1.5 Recording New Span

The *Indicatore*, calculates the new span.

```
AUTO SPAN COMPLETE
Error +/-00.00 %
Change Span ?
YES      NO
```

The word **COMPLETE** is flashing.

If **YES** is pressed, the following screen is displayed:

<p>SPAN# CHANGED Old Span#: <u>00000</u> New Span# : <u>00000</u></p> <p>RUN REPEAT FACTOR</p>
--

If **REPEAT** is pressed, go to previous section and calibration restarts.

If **NO** is pressed, the following screen is displayed:

<p>SPAN UNCHANGED Old Span#: <u>00000</u> New Span# : <u>00000</u></p> <p>MENU REPEAT FACTOR</p>
--

If **REPEAT** is pressed, go to previous section and calibration restarts.

Note: The old span and the new span are shown equally. This is because no change to the span has been done.

If **FACTOR** key– is pressed, the R-CAL factor is computed.

Note: The **FACTOR** key is available only if before is executed a Auto Span with test weights.

3.8.2.1.6 Ending an Auto Span Procedure with Test Weights

When is executed an **Auto Span** with test weights use the following procedure:

1. Press **RUN**, the following screen is displayed:

<p>Remove test weights Bifore return normal functions</p> <p>RUN Menu</p>
--

2. Press **RUN**

Restart the totalizer and returns to menu **RUN**.

3.8.2.1.7 Ending an Auto Span Procedure with R-Cal

When is executed an **Auto Span** with R-Cal use the following procedure:

1. Press **RUN**
2. **R-Cal** relay is de-energized and the display is stead for three second.
3. Press **RUN**

Restart the totalizer and returns to menu **RUN**.

3.8.2.2 Manual Span

If the span constant is known, the manual span procedure allows the operator to manually change span.

Use the following procedures:

1. Press **MENU** until indication **MENU 1**.

the following screen is displayed :

<p>-- MENU 1 -- Press menu for others</p> <p>ZERO SPAN LINEAR CAL CAL</p>

2. To select **CAL SPAN**

the following screen is displayed :

<p>AUTO SPAN XXXX Scale empty, then press START</p> <p>START MANUAL</p>

XXXX = R-Cal, Test Weights

- To select **MANUAL**
the following screen is displayed :

Manual Span	
Weight	000.0 kg
Span	00000000
ENTER	EXIT

Default: 1166667 **Min:** 500000 **Max:** 45000000

Note: If the span is manually entered, the R-CAL is invalid.

3.8.2.3 Two Point Calibration

Another way to calibrate the instrument is to use the two point calibration method. This is a method that allows calculating zero and span without knowing the exact zero value.

This function is activated by pressing the SPAN CAL key in MAIN MENU 1 after “2 points” calibration mode has been selected in CAL DATA SCROLL 1.

- Starting Two Point Calibration

AUTOSPAN Weights	
Two points calib.	
Press START	
START	MANUAL

Password: OPERATOR

Press START to begin calibration

- Defining First Point

B# S# ENTER 1° POINT	
0.00 kg	
0.0 kg	
ENTER	ACQ.

Password: OPERATOR

Enter the weight corresponding to the first point, then press ACQ.

3. Acquiring First Point

In this phase, the instrument acquires the A/D raw data for a minute. The procedure can be shorted by pressing the END key.

The following scroll is displayed during this phase :

ACQ. 1° POINT Time Remaining <u>0000</u> Weight 000.0 kg END ABORT
--

4. Defining Second Point

ENTER 2° POINT 0.00 kg 0.00 kg ENTER ACQ.

Password: OPERATOR

Enter the weight corresponding to the first point, then press ACQ.

5. Acquiring Second Point

In this phase, the instrument acquires the A/D raw data for a minute. The procedure can be shorted by pressing the END key.

The following scroll is displayed during this phase :

ACQ. 2° POINT Time Remaining <u>0000</u> Weight 000.0 kg END ABORT
--

6. Recording the New Zero and Span

At this point, the procedure is completed. The instrument computes the new zero and span and asks for confirmation to acquire the new data.

CALIB. COMPLETE Zero Error +/- 0.00% Zero and Span ch'ange ? YES NO ADV
--

COMPLETE is flashing

ADV key switches indication in second line between zero and span error.

Press YES to accept new values. The following scroll is displayed :

CALIB. COMPLETE
New Zero 00000
New Span 00000
RUN MENU

COMPLETE is flashing

Press NO to abort them. The following scroll is displayed :

CALIB. COMPLETA
Zero Invar. 00000
Span Invar. 00000
RUN MENU

COMPLETA è lampeggiante

3.8.2.4 Usual Calibration Procedure

1. Review the following screens for to insert ta data correct :
 - a. SCALE DATA (Menu 2).
 - b. CALIBRATION DATA (Menu 2).
 - c. I/O DEFINITION (Menu 4).
 - d. ALARMS DEFINITION (Menu 4).
2. Scrool until displayed MENU CALIB.DATA 1 and select calibration mode.
3. To execute a Auto Zero Calibration (see section 3.8.1.)
4. After Auto Zero procedure completed, to execute a Span calibrationome (see section 3.8.2.)
5. Recording the new New Zero and Span data on a table.

3.8.3 Linearization

Manual linearization can be accomplished by applying a known test weight(s) or loading the bin with pre-weighed material and calculation the scale error.

Press **CHOICE** for selections, **YES** to enable, or **NO** to disable linearization. Once enabled, no linearization is done until the operator manually enters the linearization factors.

<p>- LINEARIZ. 1 - Linearization <u>NO</u> CHOICE ENTER</p>
--

Password:Service

Default: No **Selezioni:** Yes, No

The linearization factors can be entered with the following screens.

If you enter 1.000 (default value), the load will not be corrected in that portion of the range. A number lower than 1.000 will reduce the span, while a number larger than 1.000 will increase the span.

<p>- LINEARIZATION #1 - Weight 0,0 kg Fact. 1,000000 ENTER ACQ FACTOR</p>

Password:Service

Factor: Default: 1.000 **Min:** 0.500 **Max:** 1.500

Then to insert the weight values and corresponding factors, until 5 different points.

(Pressing ACQ for acquired actual weight value). Then to insert until 5 points.

3.9 Setup and Configuration Menu

The following menu, from **MENU 2** to **MENU 5** are used for **SETUP** , **CONFIGURATION** and **DIAGNOSTIC** of the system.

For **MENU 2** selection press SETUP key then ARROW DOWN until the screen **MAIN MENU 2**. The submenu available are:

- *Display*
- *Scale Data*
- *Calibrazione Data*

3.9.1 Display

The Display menu contains system and *Indicator* parameters.

3.9.2 Measure Units

Measure units can be individually selected. The user must first decide if the English units will be used or the Metric ones, or combination of both.

```
-- DISPLAY SCROLL 1 --  
Measure units  
>English<  
  
CHOICE  ENTER
```

Default: ENGLISH (if USA language)
METRIC (if ESP language)

Choices: ENGLISH, METRIC, MIXED
If English, all units in English
If Metric, all units Metric
If Mixed, units may be a combination of English
and Metric

Press **ENTER** soft key to accept the default unit, or **CHOICES** soft key to scroll selections.
Press **ENTER** to confirm your selection. Scroll down.

Note: If the Measure units are changed from English to Metric (or vice versa) after the scale is calibrated, the span number changes but the calibration remains the same.

è stata calibrata, il valore dello span cambia ma la calibrazione rimane la stessa.

3.9.3 Weight Units

The weights will be displayed according to the units selected here.

```
-- DISPLAY SCROLL2 --  
Weight Units  
>Pounds<  
CHOICE  ENTER
```

English	Metric	If Mixed
Default: Pounds	Default: kg	Default: Pounds
Choices: Perc %, Pounds Tons, LTons	Choice: Perc %,kg Tonnes	Choice: Perc %,kg,Tonnes, Pounds, Tons, LTons.

Press **ENTER** soft key to accept the default unit, or **CHOICES** soft key to scroll selections.
Press **ENTER** to confirm your selection. Scroll down.

3.9.4 Totals Unit

The units to be used for Total are selected here. Press **ENTER** soft key to accept the default unit, or **CHOICES** soft key to scroll selections. Press **ENTER** to confirm your selection. Scroll down.

```
-- DISPLAY SCROLL 3 --  
Total Units  
>t<  
CHOICE      ENTER
```

English

Default: Tons

Choices: Tons, Ltons, Pounds

Metric

Default: Tonnes

Choices: Tonnes, kg

If Mixed

Default: Tons

Choices: Tons, Ltons, Pounds,
Tonnes, kg

Press **ENTER** soft key to accept the default unit, or **CHOICES** soft key to scroll selections. Press **ENTER** to confirm your selection. Scroll down.

3.9.5 Defining Language

The *MINI CK100* is a dual language instrument. USA is always the first language. The second language available can be selected (consult choice factory). Press the desired language.

```
-- DISPLAY SCROLL 4 --  
Language  
>USA<  
CHOICE      ENTER
```

Default: USA

Choices: Ita (Italian)

3.9.6 Time and Date Mode (option COMM)

The operator defines the format for displaying time (scroll 5) and date (scroll 6).

```
-- DISPLAY SCROLL 5 --  
Time  
> 24 h <  
CHOICE      ENTER
```

If USA or English : **Default :** am/pm

If other language : **Default :** 24 h

Selection : am/pm, 24 h

```
-- DISPLAY SCROLL 6 --  
Date  
> DD-MM-YYYY <  
CHOICE      ENTER
```

If USA : **Default :** MM-DD-YYYY

If other language : **Default :** DD-MM-YYYY

Selection : DD-MM-YYYY, MM-DD-YYYY, YYYY-MM-DD

3.9.7 Line (2) Display of Run Menu

The RUN MENU can be configured to display on line 2 and/or 3 either weight, master total, reset total, date and time and graphic indication of the net weight.

```
-- DISPLAY SCROLL 7 -  
Run display line 2  
> Weight <  
  
CHOICE ENTER
```

Default: NO DISPLAY

Choices: NO DISPLAY, WEIGHT, PEAK, RESET TOT, MASTER TOT, DATE/TIME, BARGRAPH

3.9.8 Line (3) Display of Run Menu

```
-- DISPLAY SCROLL 8 --  
Run display line 3  
> No Display <  
  
CHOICE ENTER
```

Default: NO DISPLAY

Choices: NO DISPLAY, WEIGHT, PEAK, RESET TOT, MASTER TOT, DATE/TIME, BARGRAPH

3.9.9 Display Damping Factors

The process variable when displayed on the screen can be damped by a programmable factor, to filter out variations that can be introduced by mechanical vibrations. To tune a damping filter, enter the number of seconds corresponding to the desired time constant. If, for example, 10 seconds is entered, the process variable reaches the stability after a step change in 10 seconds.

```
-- DISPLAY SCROLL 9 --  
Display weight  
Damping 4 sec  
  
ENTER
```

Password:Operator

Default: 4 sec

Min: 0 sec

Max: 400 sec

3.9.10 Acquiring Tare

The TARE mode function, allows tare to be set automatically or manually in the RUN scroll.

```
-- DISPLAY SCROLL 11 --  
Tare Mode  
>ACQUIRE<  
  
CHOICE      ENTER
```

Default: Acquire
Choices: Acquire, Manual

If ACQUIRE is selected, Tare is automatically acquired when the S/R TARE key is pressed or by digital input.

If MANUAL is selected, tare may be entered through the keypad when the S/R TARE key is pressed .

3.10 Scale Data Scroll

3.10.1 Scale Capacity

The scale capacity is the maximum capacity of the scale.

```
-- SC DATA SCROLL 2 --  
Max Scale Capacity  
2000.0 kg  
  
ENTER SCALE#
```

Default: 2000.0 **Min:** 1 **Max:** 100000

3.10.2 Divisions

The division corresponding to the just entered Scale Capacity (in the example 0.1).If required, the operator is able to alter the Scale Division to any of the available options.

```
-- SC DATA SCROLL 3 --  
Scale Divisions  
>0.1<  
  
CHOICE      ENTER
```

Default: 0.1
Choices: 0.1, 0.2, 0.5, 1, 2, 5, 10, 20, 50, 0.01, 0.02, 0.05, 0.001, 0.002, 0.005

3.10.3 Defining the Load Cell(s)

3.10.3.1 Number of Load Cells

Enter the number of load cells of the scale

```
-- SC DATA SCROLL 6 --  
Load cell number  
1  
  
ENTER
```

Password: Service

Default: 1 Min: 1 Max: 6

3.10.3.2 Load Cell Capacity

Enter the load cell capacity as it appears on the label placet on the load cell.

```
-- SC DATA SCROLL 7 --  
Load cell capacity  
2000.0 kg  
  
ENTER
```

Password:Service

English/Mixed

Default: 250.0 Lbs

Min: 10 Lbs

Max: 15000 Lbs

Metric

Default: 100 kg

Min: 1 kg

Max: 15000 kg

3.10.3.3 Load Cell Sensitivity

Enter the load cell sensitivity in mV/V as marked on the label of the load cell. Thermo Ramsey load cells are normally 2.000 or 3.000 mV/V.

```
-- SC DATA SCROLL 8 --  
Load cell sensitivity  
2.00 mV/V  
  
ENTER
```

Password:Service

Default: 2.0 mV/V Min: 0.500 mV/V Max: 3.500 mV/V

3.10.3.4 Load Cell Resistance

The resistance value of the bridge of each load cell has to be entered here. The number of scroll depends on the number of load cells of the system specified on the **MENU 3**.

<p>--SC DATA SCROLL 9A - - Resistance Load cell N # <u>350.000 Ohms</u></p>

Password:Service

X = A, B, C, D, E, o F

N = 1, 2, 3, 4, 5, o 6

Default: 350 Ohms **Min:** 10 Ohms **Max:** 2000 Ohms

Note: For each load cell must be inserted the value on the corresponding screen.

3.10.4 Stable Weight

These Scrolls define the parameters for the stable weight indication. Motion band defines the range on which the weight should stay in order to be considered stable.

<p>--SC DATA SCROLL 11A -- Motion Band division <u>1</u> ENTER</p>

Password:Service

Default: 1 **Min:** 0 **Max:** 3

3.10.5 Stable Weight Delay

The motion delay defines how many times this condition should be true before stable weight indication turns on.

<p>-- SC DATA SCROLL 11B - Motion delay <u>1.0 sec</u> ENTER</p>

Password:Service

Default: 1 **Min:** 0 **Max:** 60

3.11 Calibration Data Scroll

The CAL DATA Scroll allows the operator to set parameters which relate to the calibration of the scale.

3.11.1 Calibration Mode

Select which simulated method of automatic calibration is normally by used. The select method is the only one displayed in the calibration section MENU 1.

<p>-- CAL DATA SCROLL. 1 -- Calibration Mode: <u>> R-CAL <</u></p> <p>CHOICE ENTER</p>	<p>Password:Service</p>
---	-------------------------

Default: R-CAL **Choices:** R-CAL, WEIGHTS, 2 POINTS

3.11.1.1 Test Weight Parameters

This section only applies if TEST WEIGHTS mode was selected as the preferred method. Enter the weight of the test weights that are going to be used for the calibration.

<p>-- CAL DATA SCROLL 2 -- Total test weight on scale <u>0.000 kg</u></p> <p>ENTER</p>	<p>Password:Service</p>
--	-------------------------

English/Mixed	Metric
Default: 000.0 Lbs	Default: 0.000 kg
Min: 0.000	Min: 0.000
Max: 5000.000	Max: 5000.000

3.11.1.2 R-Cal Parameters

This section only applies if R-CAL mode was selected as the preferred method. Enter the resistance in Ohms of the electronic resistance installed in the instrument. If no changes, the default value applies.

<p>--CAL DATA SCROLL 3 -- R-Cal selected res 165000 ohms</p> <p>ENTER</p>	<p>Password:Service</p>
---	-------------------------

Default: 165000 Ohms **Min:** 10 Ohms **Max:** 1000000 Ohms

The system calculates the CALCON (Calibration Constant) based on the mechanical and electrical parameters entered in the Scale Data Scroll.

This menu is for reference only.

```
-- CAL DATA SCROLL 4 --  
R-CAL Constant  
00.00  
  
MENU
```

The R-Cal factor can be computed during the autospan function and used to correct the error between the two span methods.

```
-- CAL DATA SCROLL 5 --  
RCAL Factor  
Invalid  
  
ENTER +/-
```

Password:Service

Default: INVALID (0) **Min:** -99,99% **Max:** +99,99%

3.11.2 Calibration Interval (Option COMM)

The system can be programmed to prompt the operator when a certain amount of time has passed since the last calibration. If you do not want to use this option, confirm the default 0 days interval, otherwise enter the number of days. The calibration date displayed in Scroll 9 is automatically updated whenever a calibration is performed. If a non zero value is entered, an alarm appears after the time is elapsed. The alarm can only be cleared after a calibration check is executed.

```
--CAL DATA SCROLL 6 --  
Calibration Interval  
365 Days  
  
ENTER
```

Password:Operator

Default: 0 Days **Min:** 0 Days **Max:** 365 Days

This scroll displays the date of the last calibration and the expected date of the next one, based on the entry in the previous screen.

```
-- CAL DATA SCROLL 7--
Calibration date
Last: MM-DD-YYYY
Next: MM-DD-YYYY
```

3.11.3 Defining Auto Zero Tracking (AZT)

A periodical auto zero procedure can be automatically executed by the system if the Auto Zero tracking option is set to YES. This compensates for small amounts of material which may fall on weighing section of the scale

```
-- CAL DATA SCROLL 8 --
Auto Zero Tracking
> yes <
CHOICE ENTER
```

Password: Operator

Default: NO
Selections: YES, NO

The following scrolls are only visible if Auto Zero Tracking is enabled for the selected physical scale.

Define the range of the AZT with reference to the scale capacity

```
-- CAL DATA SCROLL 8A--
Auto Zero Tracking
range +/- 4 %
ENTER
```

Password: Operator

Default: +/- 4 %
Min: +/- 0 %
Max: +/- 10%

```
-- CAL DATA SCROLL 8B--
Auto Zero Tracking
max dev +/- 4 %
ENTER SCALE#
```

Password: Service

Default: +/- 4 %
Min: +/- 0 %

Define the duration time of the autozero cycle.

Password: Operator

```

-- CAL DATA SCROLL 8C--
Auto Zero Tracking
duration 20 sec
ENTER          SCALE#

```

Default: 20 sec
Min: 2 sec
Max: 60 sec

```

-- CAL DATA SCROLL 9--
Drift
CHOICE        ENTER

```

3.12 Main Menu 3

MAIN MENU 3 is used for protecting and un-protecting the system using passwords, and to perform diagnostic and test functions. The diagnostic functions can only be operated after removing all password protection, and should only be used by experienced technical personnel. Most test functions are not password protected.

```

-- MAIN MENU 3 -
Press MENU for more
PROT  DIAG  TEST

```

The **PROTECTION** menu only becomes visible after passwords have been defined (see the **DIAGNOSTICS** Menu).

3.12.1 Changing Protection Level

The *MiniCK100* has three protection levels to which specific password are related.

Table 3-2: Protection Levels

Protection	Password	Status
NONE	SERVICE	The system is completely unprotected; all data can be read or changed.
LIMITED	OPERATOR	Operator functions and data are unprotected. All setup and calibration data are protected except zero calibrate.
PROTECTED		The system is totally protected, process data can be read, no change allowed.

A **SERVICE** password is required to access the **NONE** level. An **OPERATOR** or a **SERVICE** password is required to access the **LIMITED** level.

Use the **NONE** key to access the **NONE** protection level. If the current level is not already **NONE**, the **SERVICE** password is required.

Use the **LTD** key to access the limited protection level. If the system is in level **NONE**, change is immediate. If it is in **PROT** level, the **SERVICE** or **OPERATOR** password is required. Use the **PROT** key to access the protected level. No password is required.

<p>- PROTECTION LEVEL - > NONE <</p>

Default:	NONE
Selections:	NONE, LIMITED, PROTECTED
Password:	from NONE to LTD or PROT: not required
	from LTD to PROT: not required
	from LTD to NONE: SERVICE
	from PROT to NONE: SERVICE
	from PROT to LTD: OPERATOR or SERVICE

Pressing the soft key gives entry to desired level. Going from a low level to a higher level forces the password entry.

3.12.1.1 Online Procedure for Changing Protection Level

The protection level can be temporarily changed by entering a password "on the fly" during normal operation. When the operator tries to enter a variable or select a function, which is password protected, and the password is installed, the following screen is displayed.

```
- SYSTEM PROTECTED
-
PLEASE ENTER
PASSWORD_____
```

The operator can enter either the OPERATOR or the SERVICE passwords. However, if the operator enters the OPERATOR password and the variable or function requires the SERVICE password instead, the access is denied and the following screen is displayed.

```
- SYSTEM PROTECTED -
PLEASE ENTER SERVICE
PASSWORD _____
ENTER
```

If the operator fails to enter the correct password, the following screen displays.

```
- SYSTEM PROTECTED
-
INVALID PASSWORD
ACCESS DENIED
```

Pressing **RETURN** returns the program to the previous function. If the operator enters the correct password, the previous screen appears and access is allowed.

When the protection level is changed using the on line procedure, the system automatically returns to protected status if no keyboard entries are made within 60 seconds.

3.13 Diagnostics

3.13.1 A/D Raw Data

Diagnostic Scroll 1 shows the raw data from the A/D converter of the *Integrator* (A/D gross) and the net value after the zero constant has been subtracted. The range of the A/D converter is from 0 to 131070 numbers.

```
-DIAGNOSTIC SCROLL 1-

A/D gross 00000
A/D net   0000
```

3.13.2 Readout Load Cell mV

The system displays the mV output of the load cell. The reading must be positive and must increase when the load increases.

```
-DIAGNOSTIC SCROLL 2-  
Weight on load cell  
0.000 mV  
CALIB
```

Password:Service

If **CALIB** is pressed, the next two scrolls are displayed and can be used to fine-tune the readout of mV/V.

```
-DIAGNOST. SCROLL 2A  
Loadcell output zero  
15 A/D counts  
ENTER SCALE #
```

Password: Service

Default: 15
Min: 0
Max: 10000

```
-DIAGNOST. SCROLL 2B  
Loadcell output span  
3497  
ENTER SCALE #
```

Password: Service

Default: 3497
Min: 0
Max: 30000

```
-DIAGNOST. SCROLL 3  
Mechanical Tare  
7
```

```
-DIAGNOST. SCROLL 4  
Action Gain  
1
```

```
-DIAGNOST. SCROLL 5  
Drift
```

NOTA. DIAGNOSTICS 3,4,5 ARE DISABLED.

3.13.3 Change Passwords

Change the password by entering a new one. The user can enter up to eight characters (numeric keys entries). The entered numbers are not echoed on the screen. Pressing just the **ENTER** key removes the password.

```
-DIAGNOST. SCROLL 6-  
ENTER SERVICE  
PASSWORD *****  
ENTER
```

Password: Service

Default: No password

Dopo che la password è stata inserita, il sistema ne richiede la conferma per prevenire eventuali errori nella digitazione del codice.

```
-DIAGNOSTICI 6-  
Reimposta chiave di  
SERVIZIO *****  
ENTER
```

Se la password inserita la seconda volta è uguale alla prima, viene visualizzato il seguente messaggio. After the password has been entered, the system asks for confirmation. This prevents losing access control due to a typing mistake while entering passwords.

```
-DIAGNOST. SCROLL 6-  
REENTER SERVICE  
PASSWORD *****  
ENTER
```

If the password entered the second time matches the first, the following message confirms the entry.

```
-DIAGNOST. SCROLL 6-  
NEW PASSWORD  
ACQUIRED  
RETURN
```

If the two passwords do not match, the system does not accept the new password.

```
-DIAGNOST. SCROLL 6-  
INVALID PASSWORD  
RETURN
```

```
-DIAGNOST. SCROLL 7-  
ENTER OPERATOR  
PASSWORD *****  
MENU ENTER
```

Password: Operator

Default: No password

The OPERATOR password is double checked similarly to the service one. It is strongly suggested to write down the password and preserve a copy in a safe place. If the password is forgotten, refer to Section 4.8 to remove a forgotten password.

3.13.4 Display Software Version

The software version is displayed for reference only.

```
-DIAGNOST. SCROLL 9-  
Software  
version:  
92 . XX . XX . XX
```

3.13.5 Setup Date and Time (Option COMM)

The user can set the current date and time. A battery operated clock calendar then maintains time and date even if power is removed. Day, Month, and Year are entered in sequence.

```
-DIAGNOST. SCROLL 10-  
Date: DD-MM-YYYY  
DAY: DD  
ENTER
```

Password: SERVICE

Default: 00-00-0000
Min: 01-01-0000
Max: 31-12-2096

Time is entered in a similar way. The AM/PM key is used when time is in the English mode. See **DISPLAY SCROLL 7 IN MAIN MENU 2**.

```
-DIAGNOST. SCROLL 10-  
Time: HH:MM  
HOURS: _____  
ENTER AM/PM
```

	24-hour	am/pm
Default:	00.00	01.00
Min:	00.00	01.00
Max:	23:59	12:59

3.13.6 Check Hardware Configuration

The system automatically recognizes when optional boards are installed.

The following screen is displayed for each optional plug-in board installed in the slot.

```
-DIAGNOSTIC 11-  
Board type slot  
  
BOARD TYPE
```

Optional Boards

- | | |
|------------|-------------------------------|
| - Profibus | Optional Board Profibus DP |
| - Serial | Optional Serial Board |
| - I/Out | Optional Board Current Output |

3.13.7 Force Cold Start

This scroll is used to force a cold start of the instrument in the event the software becomes corrupted. Factory defaults will be installed when the instrument restarts; all filed entry data will be replaced.

```
-DIAGNOST. SCROLL 13  
Force cold start  
  
ENTER
```

3.13.8 Lamp Test

Press **START** to begin a Lamp Test of the *MINI CK100*. All LED's and digits of the display blink for a number of seconds.

```
- TEST SCROLL 1 -  
LAMP TEST  
  
START
```

3.13.9 Test Digital Inputs / Digital Outputs

The next screen is used to check the digital input circuitry. The display shows a 1 if the specific input is closed, 0 if open.

```
- TEST SCROLL 3 -  
Digital Input test -----00  
Input # 1 :      ON/OFF  
ENTER          ON/OFF
```

```
- TEST SCROLL 4 -  
Digital Output test -----00  
Output # 1 :     ON/OFF  
ENTER           ON/OFF
```

To force an output, enter the desired number followed by **ENTER**. Then use the **ON/OFF** key to force it to the **ON** or **OFF** status. After the output has been forced, the **CLEAR** soft key appears in the middle position.



WARNING

FORCING THE DIGITAL OUTPUTS MAY CAUSE MACHINERY TO START. AFTER THE USER TRIES TO FORCE AN OUTPUT, THE FOLLOWING MESSAGE DISPLAYS.

**WARNING
EQUIPMENT MAY START**

CONTINUE ABORT



WARNING

IF THE USER PRESSES CONTINUE, BE AWARE THE ACTION MAY CAUSE DAMAGE OR INJURY. IF THE USER PRESSES ABORT, THE SYSTEM RETURNS TO THE PREVIOUS SCROLL.

3.13.10 Test Current Output (Option IOU)

```
- TEST SCROLL 5-  
Current output #1  
  00.0 mA  
ENTER
```

Default: 4.0 mA **Min:** 0.0 mA **Max:** 20.0 mA

To force the output, enter the desired number of milliamps and press **ENTER**.

3.13.11 Test Communication A (Option COMM)

The following screen allows to check the serial lines option installed.

```
- TEST SCROLL 8 -  
Test Communication A  
  
Start
```

By pressing the **START**, the test is initiated. A test pattern is sent out on the TX output and read on the RX input. If the test fails, the message "Test Failed" is shown; otherwise, the message "Test Passed" is displayed.

3.13.11.1 Test RS232

To test RS232 the test requires a hardware jumper to be installed between terminals (RX) and (TX).

3.13.11.2 Test RS485

To test the RS485 the test requires a hardware jumper to be installed between terminals RX+/TX+ and RX-/TX-.

3.13.12 Test Keyboard

```
- TEST SCROLL 12 -  
Keyboard  
  
Key: _____
```

Press the **RUN/SETUP** key twice to exit. All other keys, including **MENU**, are displayed but not executed.

3.14 Main Menu 4

The following section defines the input output (I/O) and alarms.

```
- MENU 4 -  
Press MENU for more  
I/O ALARM NET  
DEFINE DEFINE
```

3.14.1 I/O Definition

The input output section of the system is fully configurable. All inputs and outputs are conventionally numbered and can be assigned to physical input and output terminals depending on the needs. The following section explains how to configure I/O. However, the standard configuration as provided by the factory is normally satisfactory.

3.14.1.1 Define Current Outputs (Option. IOU)

The following menus are shown for configuring the current output(s). Use the **CHOICE** key to change the variable and the **ENTER** key to confirm.

```
- I/O DEF SCROLL 1 -  
Current Output  
> Net <  
CHOICE ENTER
```

Password:Service

Default: Net
Choices: Net, Gross, Tare, Peack

The following scrolls allow to define the range, delay and damping factor of current output.

```
- I/O DEF SCROLL 1A-  
Current Out Range  
> 4-20 mA <  
CHOICE ENTER
```

Password:Service

Default: 4-20 mA
Choices: 0-20 mA, 4-20 mA, 20-0 mA, 20-4 mA

```
I/O DEF SCROLL 1B-  
Current Out Delay  
#1 0 sec  
ENTER
```

Password: Service

Default: 0 sec **Min:** 0 sec **Max:** 300 sec

A damping factor can also be selected. The damping factor is the time for the output to stabilize after a step change. This damping only affects the current output, not the displayed variable, which has a separate damping factor, selectable in Main Menu 2, Display.

<p>- I/O DEF SCROLL 1C- Current Out Damping #1 <u>4 sec</u> ENTER NEXT</p>
--

Password:Operator

Default: 4 sec **Min:** 0 sec **Max:** 400 sec

3.14.2 Digital Inputs Definition

Digital inputs can be programmed. The following screen allows the user to assign a physical input. The **NEXT** key scrolls between the logical function availables. The **NC/NO** key selects the Normally Open (NO) or Normally Closed (NC) status of the input. Normally Open means the input is inactive when disconnected. To program a function, scroll with **NEXT** until the function is displayed, then enter the physical input number and confirm with **ENTER**; finally scroll with **NC/NO** until the desired mode is displayed. By assigning a function to 0, the function is disabled.

<p>- I/O DEF SCROLL 4 - Dig. Input def. Ext Alarm 1 <u>0 NC</u> ENTER NC/NO NEXT</p>
--

Password:Service

The following table shows the available logical selections that can be assigned to any available physical input.

The input (default) selections are the following :

- Input #1 Reset Tare
- Input #2 Set Tare

 CAUTION
<p>LOGICAL INPUTS RETURN TO THE DEFAULT IF THE INSTRUMENT IS COLD STARTED.</p>

Table 3-3: Available Logical Selections

Selections:	Default:	
External alarm 1	0 NO	0 = function disabled
Reset Alarms	0 NO	
Print	0 NO	(Only if print is enable)
Reset Tare	1 NO	
Set Tare	2 NO	
Auto Zero	0 NO	(Only if AZT is enable)
Reset Tot.	0 NO	
Add to Tot.	0 NO	
Hold	0 NO	
Reset Peak	0 NO	

 <b style="color: red; font-weight: bold;">WARNING	
<p>CHANGING THE DEFINITION OF THE DIGITAL INPUTS MAY CAUSE MACHINERY TO START. AFTER THE USER TRIES TO CHANGE A DEFINITION, THE FOLLOWING MESSAGE IS DISPLAYED.</p>	
<table border="1" style="margin: auto; text-align: center; width: 80%;"> <tr> <td style="padding: 5px;"> WARNING EQUIPMENT MAY START CONTINUE ABORT </td> </tr> </table>	WARNING EQUIPMENT MAY START CONTINUE ABORT
WARNING EQUIPMENT MAY START CONTINUE ABORT	
<p>IF THE USER PRESSES CONTINUE, BE AWARE THE ACTION MAY CAUSE DAMAGE OR INJURY. IF THE USER PRESSES ABORT, THE SYSTEM WILL RETURN TO THE PREVIOUS SCROLL.</p>	

3.14.3 Digital Outputs Definition

Digital outputs can be programmed. The following screen shows one logical function per time, and allows the user to assign it to a physical output. The **NEXT** key scrolls between the logical functions. The **NC/NO** key selects the Normally Open (NO) or Normally Closed (NC) status of the output. Normally Open means the output is not energized in normal conditions. To program a function, scroll with **NEXT** until the function is displayed, then enter the number of the physical output and confirm with **ENTER**; finally scroll with **NC/NO** until the desired mode is displayed. By assigning a function to 0, the function is disabled.

```
- I/O DEF SCROLL 5 -  
Dig. Output def.  
Alarm 2 NC  
ENTER NC/NO NEXT
```

Password:Service

Default Selections :

- Output #1 – NC ALARMS
- Output #2 (TTL) – 0 (Not used)
- Output #3 (TTL) – 0 (Not used)
- Output #4 (TTL) – 0 (Not used)
- Output #5 (TTL) – 0 (Not used)

NOTE

TTL #3-#6 outputs can be used with expansion digital output boards connected by flat cable with blue connector DIG OUT.

Is available n°1 digital output optocoupled that can be connected (direct) with field. This output #1 is available on connector DIG IN-OUT pins 6 and 7.



CAUTION

LOGICAL SELECTIONS RETURN TO THE DEFAULT IF THE
INSTRUMENT IS COLD STARTED.

The following table shows the logical selection that can be assigned to any available physical output .

Table 3-4: Available Logical Assignment

Selections	Default	
Alarm	1 NC	
Shut down	0 NO	
Ready	0 NO	
Weight Stable	0 NO	
mA sig. pol.	0 NO	(Only if current output is available)
Thres.#1	1 NO	(Only if available Threshold #1)
Thres.#2	2 NO	(Only if available Threshold #2)
Thres.#3	3 NO	(Only if available Threshold #3)
Thres.#4	4 NO	(Only if available Threshold #4)
Totalized	0 NO	

 WARNING
<p>CHANGING THE DEFINITION OF THE DIGITAL OUTPUTS MAY CAUSE MACHINERY TO START AFTER THE USER TRIES TO CHANGE A DEFINITION. THE FOLLOWING MESSAGE IS DISPLAYED.</p> <div style="border: 1px solid black; padding: 10px; margin: 10px auto; width: 80%;"> <p>WARNING EQUIPMENT MAY START CONTINUE ABORT</p> </div> <p>IF THE USER PRESSES CONTINUE, BE AWARE THE ACTION MAY CAUSE DAMAGE OR INJURY. IF THE USER PRESSES ABORT, THE SYSTEM RETURNS TO THE PREVIOUS SCROLL.</p>

3.15 Alarms Definition

The alarms of the MiniCK100 can be programmed. Process alarms such as low and high weight can be set to the desired range. In addition, all alarms can be defined to be:

- **ALARM**-When an alarm occurs, the front panel ALARM status indicator illuminates. An ALARM message flashes in the lower, right hand RUN display. Pressing ALARM displays the alarm. (Data and time are showed if installed Option COMM).
- Pressing RESET clears the alarm message if the alarm parameter has cleared. If the alarm parameter has not cleared, the message "ACK" appears when RESET is pressed. When the alarm parameter clears, the alarm indication clears.

Pressing RUN at any time returns the operator to the RUN menu.

Alarms can be automatically printed if the print option is enabled.

- **SHUT DOWN**The alarm handler operates as above except the READY status indicator goes off and the SHUTDOWN physical output changes state at the same time as the ALARM status indicator comes on.

In the I/O definition scroll, alarm and ready can be assigned to N/C or N/O physical outputs. The output activates and deactivates at the same time as the front panel status indicators.

- **NONE** Alarm is deactivated.

3.15.1 Alarm Definition Threshold #1

Use the **CHOICE** key to turn on or off the threshold #1 alarm. Confirm with **ENTER**.

- ALARM SCROLL 1 -	
Threshold #1	
>no<	
YES	NO

Password:Operator

Default: No **Selections:** Yes, No,

If the selection in the previous screen was YES, enter the threshold set points for the alarm.

The **UNITS** key allows the operator to specify the set points in engineering units. The **%** key selects set points in percent referring to scale capacity

- ALARM SCROLL 1A -	
Threshold #1,	
Set <u>10</u> %	
ENTER UNIT/%	

Password:Operator

Default: 10% **Min:** 0 % **Max:** 105 %

Enter the desired delay time before the alarm is monitored.

- ALARM SCROLL 1B -
Threshold #1,
Delay 2_sec
ENTER

Password:Operator

Default: 2 sec **Min:** 0 sec **Max:** 90 sec

Insert HYST. value for a correspondent compensation range of the threshold.

The **UNITS** key allows the operator to specify the set points in engineering units. The **%** key selects set points in percent referring to scale capacity.

- ALARM SCROLL 1C -
Threshold #1,
Hys. 1 %
ENTER UNITS

Password:Operator

Default: 1% **Min:** 0% **Max:** 105%

Insert the threshold selection level , positive (high) or negative (low).

- ALARM SCROLL 1D -
Threshold #1, mode
> Low level <
CHOICE ENTER

Password:Operator

Default: Low level **Selections:** Low level, High level.

Insert the threshold selection variable.

- ALARM SCROLL 1E -
Threshold #1,
Var. > Net<
CHOICE ENTER

Password:Operator

Default: Net. **Selections:** Net, Gross, Net ABS, Gross ABS

3.15.2 Alarm Definition Threshold #2

The definition of threshold #2 can be made with the same modalities defined in this section.

3.15.3 Alarm Definition Threshold #3

The definition of threshold #3 can be made with the same modalities defined in this section.

3.15.4 Alarm Definition Threshold #4

The definition of threshold #4 can be made with the same modalities defined in this section.

3.15.5 Alarms Setup

The following message is displayed for three seconds.

```
- ALARM SCROLL 5
- Alarms Definition
Use NEXT key or enter
alarm number
```

After three seconds, the **ALARM** screen is displayed. The user can use the CHOICE soft key to select the desired mode between ALARM (just a warning message), SHUT DOWN (Warning plus fault output) and NONE (no action). Confirm with ENTER. Use the NEXT key to scroll between alarms, or enter the alarm number.

3.16 Ethernet

This menu allows to configure Ethernet channel with IP and SUBNET Mask address.

```
- ETHERNET 1 -
IP Address
_._._._.
ENTER
```

```
- ETHERNET 2 -
Subnet Mask
_._._._.
ENTER
```

The Ethernet channel is used with ModbusTCP protocol (port 502) and can be connected until 3 connections.

```
- ETHERNET 3 -
Mac Address
_._._._.
ENTER
```

3.17 Main Menu 5 (Option COMM or Option PROFIBUS)

Main Menu 5 is dedicated to the serial/profibus option. **COMM A** is used to set up the serial/profibus line and **PRINT** is used for setting up the printer output. Main Menu 5 does not appear unless an optional COMM A is installed.

3.17.1 Communication A (Option COMM)

The *MINI CK100* has one serial channel, which can be configured using jumpers as an RS232 or an RS485 channel. The serial channel can be used for printing or for a serial communication with an intelligent device such as a PLC or a PC.

The following screens define the communication parameters of the channel.

COM A SCROLL 1 Baud Rate COM #1 > 2400 < CHOICE ENTER
--

Password:Service

Default: 9600 **Selections:** 110, 150, 300, 600, 1200, 2400, 4800, 9600, 19200

- COM A SCROLL 2 - Set Parity COM #1 > <u>No Parity</u> < CHOICE ENTER

Password:Service

Default: No Parity **Selections:** Even Parity, Odd Parity, No Parity

- COM A SCROLL 3 - Stop bit COM #1 > <u>1 stop bit</u> < CHOICE ENTER
--

Password:Service

Default: 1 Stop Bit **Selections:** 1 Stop Bit, 2 Stop Bits

- COM A SCROLL 4 - Wordlength COM #1 > <u>8 bits</u> < CHOICE ENTER
--

Password:Service

Default: 8 Bits **Selections:** 7 Bits, 8 Bits

The following screens defines the utilization of the serial channel. The protocol is MODBUS RTU.

```
- COM A SCROLL 5 -  
Protocol COM #1  
> Printer <  
CHOICE      ENTER
```

Password:Service

Default: Printer **Selections:** Modbus, Printer

If the selected protocol is PRINTER, the following screens define the CTS use.

```
- COM A SCROLL 11 -  
CTS COM #1  
> Disabled <  
CHOICE      ENTER
```

Password:Service

Default: Disabled
Selections: Enabled, Disabled

If the selected protocol is MODBUS, the following screens define the ADDRESS of the device in the multi drop line, and the access permission from the remote supervisor. If NONE is selected, the supervisor has full access to the device. If LIMITED is selected; there is supervisor only access to those variables. If PROTECTED is selected, the unit is write protected.

```
-COM A SCROLL 12 -  
Address COM #1  
1  
CHOICE      ENTER
```

Password:Service

Default: 1 **Min:** 1 **Max:** 255

```
-COM A SCROLL 13 -  
Access COM #1  
> None<  
CHOICE      ENTER
```

Password:Service

Default: None **Selection:** None, Limited, Protected

3.17.2 Print (Option COMM)

The *MINI CK100* has programmable printer format. The following section explains the printer format.

PRINT TOTALS
Date: 03-10-1995
Time: 8:12

GROSS WEIGHT: 134.00 kg
NET WEIGHT: 104.00 kg
TARE: 30.00 kg

MASTER TOTALS: 12230.00 t
RESET TOTALS: 12230.00 t

The printing function can be activated automatically (see periodical printing function), by key PRINT on RUN MENU 1 or by contact input.

3.17.2.1 Control (Handshaking)

The system can be configured to operate without a handshake (NONE), or using the Clear to Send signal (CTS) or the XON-XOFF sequence. Refer to the printer instruction manual to define which selection is required. The selection NONE is only used for testing purposes. It is not recommended for normal use. If NONE is selected, the system is not able to recognize if the printer is on line or not, or if the paper is empty.

The most commonly used protocol is the CTS, which is a signal generated by the printer to indicate whether it is ready to receive data or not.

<p>-PRINTER SCROLL 1 - Handshaking > <u>None</u> < CHOICE ENTER</p>

Password:Service

Default: None **Selections:** None, CTS, Xon-Xoff

Different printers use different end of line patterns. Select the one you need for your printer.

```
-PRINTER SCROLL 2 -  
End of line  
> CR <  
CHOICE      ENTER
```

Password:Service

Default: Cr **Selections:** Cr, Lf, Cr+Lf

Some printers cannot accept characters while they are printing. In some cases, the handshake is not well controlled by the printer, so a delay at end of line is helpful.

```
-PRINTER SCROLL 3 -  
Delay end of line  
0 sec  
ENTER
```

Password:Service

Default: 0 sec **Min:** 0 sec **Max:** 5 sec

A form feed character can be sent to the printer after each report to force the printer to eject the paper. If NO is selected, a normal END OF LINE character(s) is printed at the end of the report.

```
PRINTER SCROLL 4 -  
Form Feed  
> NO <  
CHOICE      ENTER
```

Password:Service

Default: No **Selections:** No, Yes

3.17.2.2 Periodical Printing

If you want to generate periodical printing, enter the number of minutes, hours, or days in the following screen. Entering 0 prevents periodical printing. Use the INTV key to switch from minutes to hours and to days.

```
-PRINTER SCROLL 5 -  
Print Interval  
0 min  
ENTER      INTV
```

Password:Operator

Default: 0 min **Min:** 0 min, 0 ore, 0 days **Max:** 59 min, 23 hours, 365 days

The system can print at specific times during the day. Enter the time you want to obtain the printing. Use the NEXT key to scroll between the print times (maximum 4). The ON/OFF key enables or disables the displayed print time.

- PRINTER SCROLL 6 -
Print time # 1
Ora HH:MM
ENTER ON/OFF NEXT

Password:Operator

	If 24 hours	If am/pm
Default:	OFF	OFF
Min:	00:00	01:00
Max:	23:59	12:59

3.17.3 Profibus (Option PROFIBUS)

This menu allows to configure the Profibus-DP parameters communication. Then slave address and words buffer input (reception) and output (transmission) dimensions.

-MENU PROFIBUS 1 -
Address __

ENTER

Password:Operator

Default: 1 Min: 1 Max: 255

-MENU PROFIBUS 2 -
Buffer Input __

ENTER

Password:Operator

Default: 48 Min: 16 Max: 64 Words

-MENU PROFIBUS 3 -
Buffer Output __

ENTER

Password:Operatore

Default: 48 Min: 16 Max: 64 Words

Chapter 4

MINI CK100 Maintenance

The maintenance information in this manual should meet your service needs. If problems occur requiring technical assistance, please call Tel. 02 -9595141.

Thermo Electron has a repair center located at Rodano (MI) Tel. 02 -9595141. Contact our Repair Representative for assistance. To expedite your service request, please have your machine model and serial number available.

4.1 Frequent Checkpoints

As a preventative measure, check to ensure all wires, plugs, and integrated circuits are tight in their connectors. Also, keep the enclosure door tightly closed to prevent dirt infiltration.

More often than not, a quick visual inspection leads to the source of trouble. If a problem develops, check the following before proceeding to more specific troubleshooting procedures:

- Check Power
 1. Check the Line Voltage Selector Switches are set to the correct line voltage
 2. Check the fuse
 3. Check that the power switch is ON and that power is supplied to the unit.
- Check Connections
 4. Check that all terminations are secure.

4.2 Troubleshooting

This unit has built-in troubleshooting capabilities. A number of possible problems are automatically detected and screen messages are displayed. Also, refer to the *Diagnostics Test Scrolls* in **MAIN MENU 3**.

4.3 Alarm Messages

The ALARM message is assigned to the right hand soft key when an alarm is pending. The Alarm message and its LED flash at the same time.

The following screen is displayed when the right hand soft key is pressed.

ALARM	<u>NEW</u>
XXXXXXXXXXXXXXXXXXXXXX	
MM-DD-YYYY	HH:MM
RESET	NEXT

- **NEW** indicates an alarm that has not yet been acknowledged. When the operator presses **RESET** to clear the alarm, the alarm disappears only if the trigger for the alarm does not exist any longer. If the alarm is still pending, **ACK** is displayed instead of **NEW**.
- **NEXT** is used to scroll between the pending alarms.
- XXXXXXXXXXXXXXXXXXXX represents one of the conditions listed in Section 4.3.1..

4.3.1 Alarms List

Clock Fail

The system has detected a failure on the clock calendar circuit. (Only with COM Board option)

- ◆ Go to the **DIAGNOSTICS** screen and re-enter the date and time.
- ◆ Check the battery
- ◆ Replace the motherboard.

Load Cell Fail S#

S# identifies the scale if more scale are defined. The system has detected an error on the load cell signal.

- ◆ Check the load cell connections.
- ◆ Check the load cell(s).

RAM Fail

The system has detected an error on the *RAM (Random Access Memory)* checksum during the internal periodic test. The *RAM* is used to store variables and set up data.

- ◆ Replace the motherboard.

ROM Fail

The system has detected a failure on the *ROM (Read Only Memory) checksum* during the internal periodic test. The *ROM* is used to store the program.

- ◆ Replace the mother board

Threshold #1 S#

S# identifies the scale if more than one scale is defined. The threshold 1 has been reached.

Threshold #2 S#

S# identifies the scale if more than one scale is defined. The threshold 2 has been reached.

Threshold #3 S#

S# identifies the scale if more than one scale is defined. The threshold 3 has been reached.

Threshold #4 S#

S# identifies the scale if more than one scale is defined. The threshold 4 has been reached.

Warm Start

The system has detected a power loss condition, or power was removed for an undefined period.

Cold Start

- ◆ The system has detected the loss of the set up data after power was removed. The instrument needs to be setup and calibrated.
- ◆ Replace the motherboard

Note: The COLD START message is not displayed on the screen because cold start activates starting procedure and the alarm is automatically cleared after the installation completed. During the installation procedures the alarms are displayed and the LED alarm status is on.

P.D. Calibration

When the system is powered off while a calibration sequence is in progress, the scale may not be properly calibrated.

- ◆ Check calibration

Calib. Time

If a calibration check time is entered and the time expires, this alarm occurs. The purpose is to remind the operator that the calibration has not been checked for a considerably long period.

Ext. Alarm

Digital inputs can be programmed to detect external alarm conditions such as emergency switches, max level switches or other. This alarm is associated to the external alarm #1.

Totalizer Overflow.

The actual weight added in the total registers activates the totalizer overflow.

Math Error

A divide by zero or overflow error is encountered during internal calculations. This message indicates some abnormal dimensional parameter is entered in setup.

- ◆ Check setup data

Printer Error

This message is displayed if the system has data to print and the printer is disconnected or the paper feed is empty.

Communication Error

Indicates a time out or handshake error is detected during a data transfer on the COMM line.

- ◆ Check the COMM line connections.
- ◆ Check the COMM line setup data.

– PROFIBUS-DP COMM Error

This messages in *only* displayed if the optional Profibus board is installed. The following two conditions activate the alarm.

The *Siemens SPC3 Controller* installed on the *Profibus* interface board does not recognize any successful data transfer within the watchdog timer interval.

- ◆ The received data contains errors (value overlaps limits, register number does not exist, group number does not exist).

4.4 Cold Start

It may be necessary to cold start the *MINI CK100* in the event memory becomes corrupted. In the event of a cold start, you have the option of installing the factory default constants or simply returning the instrument to its previous running state.

The cold start can be forced through the menu **DIAGNOSITCS SCROLL** (see 3.13.7)

When the following screen displays, all field entry data has been replaced by the factory default constants.

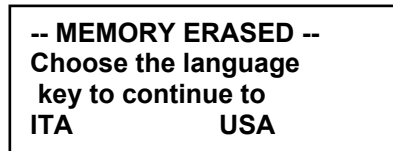

Select the language and follow the initial setup procedures.

4.5 Load Cell Excitation and Signal Voltage

1. Measure excitation voltage across terminal 21 negative and 20 positive in the scale junction box. This should be 10 VDC \pm 5%.
2. If the excitation voltage is incorrect then measure the excitation voltage in the *MINI CK100* across terminal 6 negative and the 1 positive. This should be 10 VDC \pm 5%.
3. Measure DC millivolt signal voltage across terminal 22 positive and 23 negative in the scale junction box. This should be within 0-30 millivolts DC (3 mV/V load cell).
4. Measure DC millivolt signal voltage across terminal 3 positive and 4 negative in the *MINI CK100*. This should be the same as Step 3 above.
5. The millivolt output is in direct relation to weight applied. As weight is increased, output should increase.

4.6 Lithium Battery Replacement

The *MINI CK100* volatile memory backup battery can be replaced without any special tools.



Replace only with same or equivalent type recommended by Thermo Electron. Dispose of used battery according to manufactures instruction on battery or return to Thermo Electron.

1. Turn the *MINI CK100* power off at the mains.
2. Remove the battery from its compression socket.
3. Observe the polarity markings on the battery socket base before inserting the new battery.
4. Insert battery
5. Restore power to the *MINI CK100*.
6. Re-enter date and time on instrument set up.

4.7 Disposal of Hazardous Waste

Disposal of Lithium batteries and soldered print circuit boards should be in accordance with your local Hazardous Waste Policy.

As an alternative, you may return product supplied by Thermo Electron, freight prepaid for disposal. Contact Thermo Electron Repair Department for a Return Authorization Number before shipping any product for disposal.

4.8 Cleaning Instructions

The front panel can be wiped clean with a damp cloth, and if necessary, a mild detergent (never use abrasive cleaners, especially on the display window). As a preventative measure, check all wires, plugs, and integrated circuits are tight in their connectors. Keep the enclosure door tightly closed to prevent dirt infiltration.

Chapter 5

MINI CK100 Replacement Parts

This section gives information on how to order replaceable parts for *MINI CK100*.

5.1 Order Informations

For faster service when ordering parts, fax or telephone Products Parts Department ThermoRamsey. Your regional field service representative will also be happy to assist you with parts orders, but his normal scheduling time may delay shipment of your parts order.

The recommended procedure for order parts is as follows:

1. Determine the broken or faulty part(s).
2. Locate the part(s) in the parts list given.
3. Find the part number(s) for the item(s) needed and determine the quantity you require.
4. Fax or telephone Products Parts Department ThermoRamsey.
5. With your order, list the following information:
 - ◆ Machine model and serial number
 - ◆ Purchase order number
 - ◆ Date required
 - ◆ Method of shipment preferred
 - ◆ List of parts, including part number, description and quantity

Your parts order will be handled as expeditiously as possible.

RMA NO. R- _____
(This RMA number must be marked on all paperwork
and on the outside of the package.)

Req'd By _____

Return, Freight Prepaid to:

Date: _____

Thermo Electron
501 90th Avenue N.W.
Minneapolis, MN 55433

Customer
Contact: _____

Telephone: 763.783.2774
Fax: 763.783.2525

Phone No.: (____) _____

Bill to Customer #: _____

Ship to #: _____

Returned From: _____

Return To: _____

Description of Material Being Returned:

Describe Equipment Malfunction or Defect if any. List symptoms:

Minimum Charge:

Informed Customer of \$50.00 Inspection Charge Per Item

Service Requested:

P.O. No.: _____

Repair & Return Estimate Required

Original P.O. or Job Order No.: _____

Return for Credit

Warranty Repair or Replacement

Serial No.: _____

Original P.O. No: _____

Original Order/Job No.: _____

Return Warranty/Exchange Unit

Shipped on Job Order No.: _____

Other _____

Disposition/Comments: (For internal use only)



5.2 Parts List

Table 5-1: Parts List

Equipment	PART NUMBER
Custodia + Meccanica Generale	
CPU BOARD	
KEY BOARD	
SUPPORT BOARD	
INPUT CELL BOARD	
POWER SUPPLY UNIT 100-230VAC	
POWER SUPPLY UNIT 24VDC	
Fuse 0,4Amp SB Type C	
PROFIBUS BOARD (OPTION)	
COMM BOARD RS232/485 (OPTION)	
CURRENT LOOP BOARD (OPTION)	

Appendix A

MINI CK100 Digital Input / Output

The *MINI CK100* has provision for up to 2 programmable digital inputs and 5 programmable digital outputs. Standard I/O includes one speed input, one programmable inputs, one programmable outputs, and four TTL programmable outputs.

A.1 Mother Board Digital I/O

A.1.1 Digital Inputs

- (1) Programmable digital (DC) inputs (1) Speed input
- Optically isolated
 - Powered by internal 24 VDC supply, 400 mA
 - Cable Length: 150 ohm maximum (2500m with 1.5mmq)

Appendix Figure A-1: General Purpose Digital Inputs

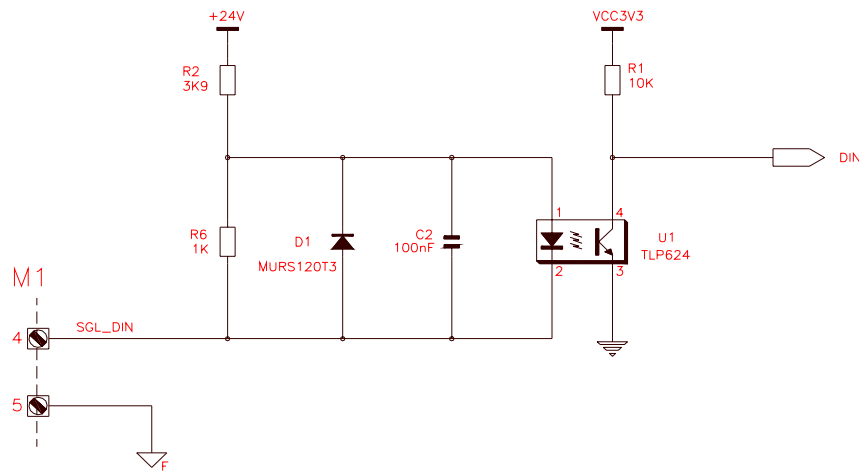

Appendix Figure A-2: State Speed Input

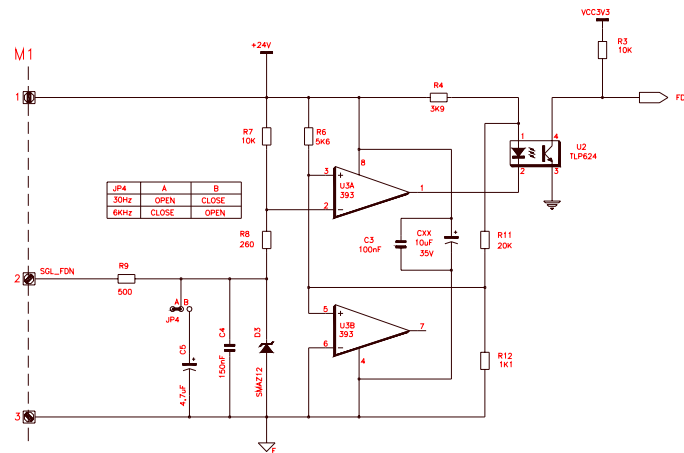

A.1.2 Digital Outputs

Appendix Figure A-3: Digital Outputs

N°1 Digital output programmable, and N°4 TTL Digital output programmables.

- Powered by internal 24 VDC supply, 400 mA
- Cable Length: 150 ohm maximum (2500m with 1.5mmq)

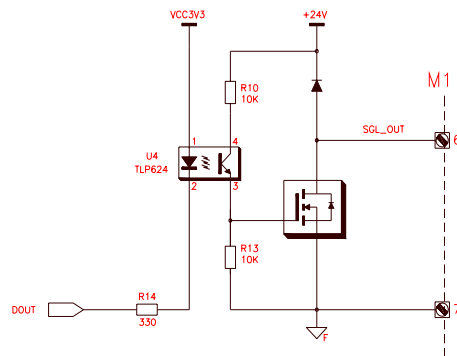

Appendix Figure A-4: State Output TTL

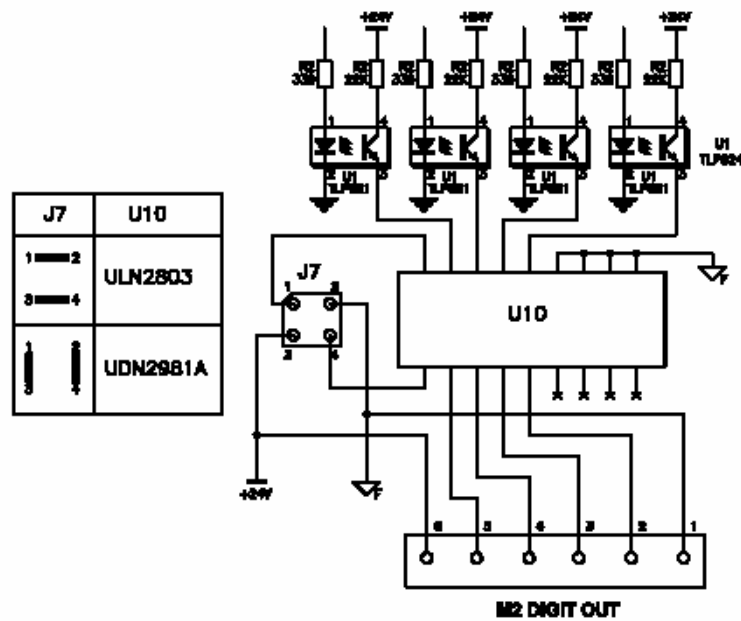

For the digital outputs is used (default) an open collector integrate UNL2803 that is mounted on socket for an easy operation of replacement. The UNL2803 can be replacement with an open emitter integrate UDN2981A. In this case is necessary to execute the jumpers indicated on the Figure a-4.

Appendix B

MINI CK100 Opzional Boards

B.1 Analog Out Board

The analog I/O board is available in the configuration described below.

Type A: Current Output Board is a user definable 0-24/4-20 or 20-4/20-0 mA output for the following functions :

Net Weight, Gross Weight, Tare, Peak

Optically isolated

Isolated power source

Voltage output by adding an internal dropping resistor

Output range: User selectable 0-20mA or 4-20 mA, representing 0 to 100% variable.

Resistive load: 800 ohms max.

Capacitive load: No limit

Appendix Figure B-1: State Current Output

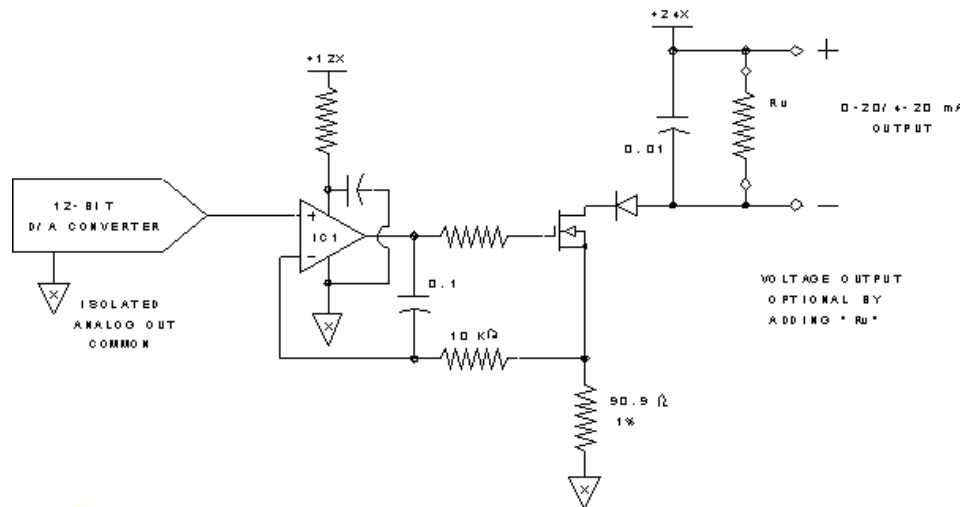

B.2 Profibus Board

Refer to *Profibus-DP manual*, if this option is installed..

B.3 Comm RS232/485 Board

Refer to *Serial Communication manual*, if this option is installed..

Appendix C

Drawings

➤ *Wiring Diagram CK-0000100-E001A*

INDICATORE TRASMETT. DI PESO WEIGHT TRANSMITT. INDICATOR MINI CK100

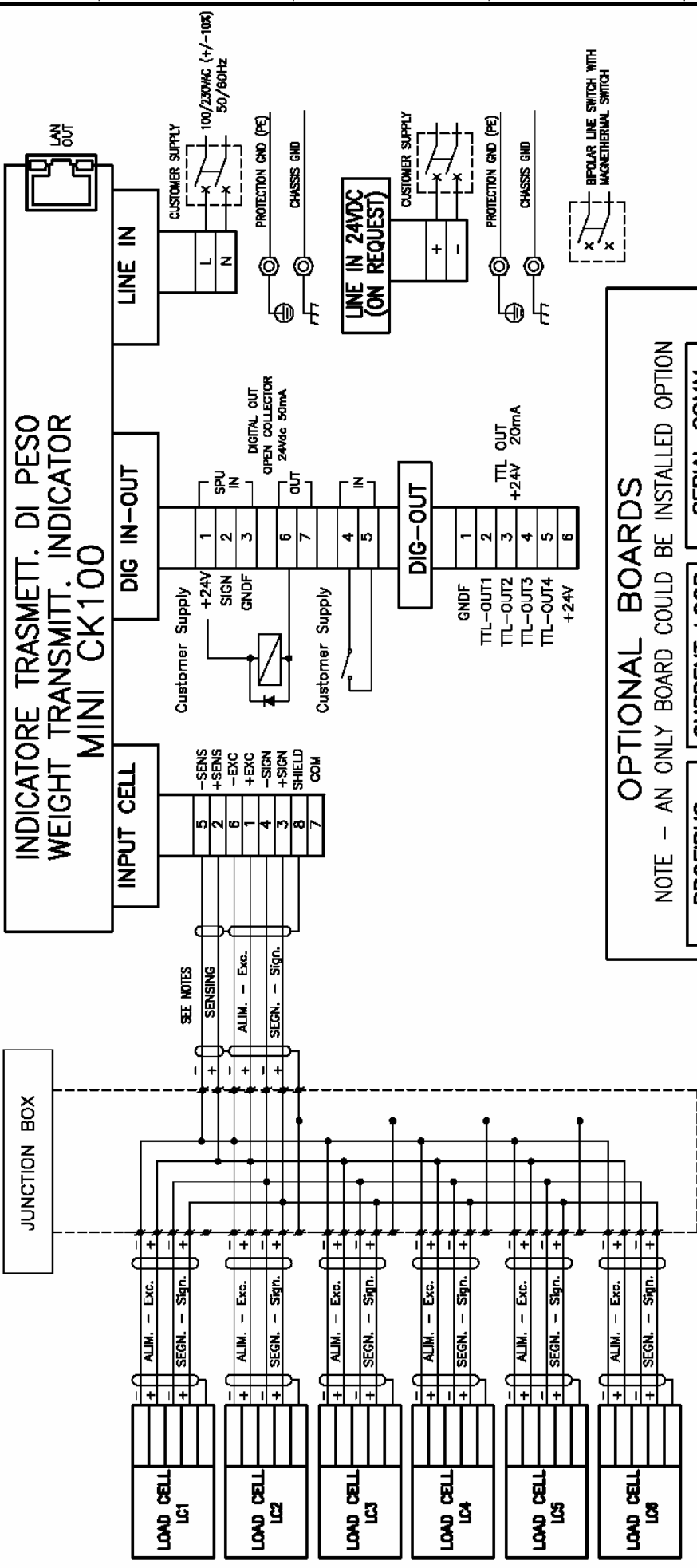

- NOTES**
- DO NOT ALTER THE LENGTH OF LOAD CELLS CABLE
 - CONNECT SHILD ONLY WHERE INDICATED
 - DO NOT WIRE SIGNAL WITH AS POWER LINES
 - USE CABLE 2x1.5mm² + shield FOR SENSING CONNECTION NECESSARY FOR DISTANCES HIGHER THAN 60m BETWEEN LOAD CELLS AND WEIGHT TRANSMITTER

OPTIONAL BOARDS
NOTE - AN ONLY BOARD COULD BE INSTALLED OPTION

PROFIBUS	CURRENT LOOP	SERIAL COMM
1 RXD/TXD-P	1 +IOUT	1 -RXD
2 RXD/TXD-N	2 -IOUT	2 +RXD
3 RTS	3	3 +TXD
4 +5VF	4	4 -TXD
5 GNDF	5	5 GND
6	6	6
	7	7
	8	8
	9	9

	CLIENTE / CUSTOMER	TIPO / TITLE	Thermo ELECTRON CORPORATION Thermo Ramsey Italia S.r.l. - Strada Rivolana Km6/7 Rodano (MI) DESCRIZIONE N° / DRAWING N°
	DATA / DATE		MINI CK100 SCHEMA INTERCONN. MORSETTIERE TERMINAL WIRING
	DATA / DATE	DATA / DATE	CK-0000100-E001A 001
REV. A	DESCRIZIONE / DESCRIPTION ISSUED	DATA / DATE 16-3-2006	FILE N° CK-0000100-E001A