



INDUSTRIAL PROCESSES

■ Moisture



CM710e

The Measure of Quality™

On-line Measurement

NDC & Industrial Processing

NDC Infrared Engineering has over 40 years of experience in the design and manufacture of on-line instruments developed specifically to meet process industry's exacting requirements for moisture measurement.

Our development team has in-depth knowledge of the physical and chemical attributes of the many products that we can measure, the measurement and control requirements in the process, and the laboratory and analytical methods used in quality assurance systems. Furthermore, we understand the ambient conditions in the process, and engineer our gauges to be insensitive to changes in relative humidity, factory lighting, process temperature and product presentation. The objective is to develop accurate, stable, robust moisture measurements that are trusted for process control.

Each CM710e Gauge is supplied with NDC's unique SpeedCal pre-calibration, leaving our facility ready to be installed in the process and quickly set up to give high performance measurements from day one.

Direct operations in Europe, Asia & the Americas and fully trained distributors world-wide, ensure that you can rely on NDC for first class local support.

Using Accurate Moisture Control to improve quality & efficiency whilst reducing energy consumption...

INDUSTRY DRIVERS



- Process Efficiency Improvements
- Product Quality
- Reducing fossil fuel consumption
- Introduction of GMP
- Implementation of automated closed-loop control systems

Automated Process Control

based on real-time on-line moisture measurement delivers some of the most significant savings in industrial processing through the improved efficiency of drying processes. Controlling and increasing product moisture content by just one percent or even less can achieve substantial improvements to process profitability while reducing energy consumption and factory emissions.

Moisture Content also plays a major role in product quality; whether optimizing spray drying of ceramic powders, controlling moisture in copper concentrates, achieving target moisture values in sinter mix, or monitoring moisture in powdered detergents – these and many other processes can benefit from tighter control of moisture levels.

The Challenge, however, is to introduce into the process a measurement which will be robust and stable enough to meet the environmental demands and accurate and reliable enough to be trusted for process control.

The nature of the process also demands specifically engineered solutions to gain access to the product to make an effective measurement.

Many products are transported on conveyors providing convenient measurement access, but pneumatic transport systems will require automatic samplers and discontinuous product flows require product presence/absence detection, and for really aggressive locations, ruggedized housings and mechanical protection will be required. In hazardous areas, there may be a need for ATEX certification.

On-Line Instrument Design must fundamentally ensure that changes in the measurement output are due solely to the varying levels of product moisture and not because of product or process variables.



The CM710e Industrial Moisture Gauge

Designed specifically for use in an Industrial Process the CM710e's robustness and stability deliver performance which is universally trusted for process control...

The **CM710e** uses precision NIR (near infrared) measurement technology to make a continuous non-contacting measurement of moisture.

With a measurement speed of 7.5 milliseconds, the patented "light engine" uses optical components manufactured by NDC's Optics division, to deliver the highest resolution on-line measurements available today.

The CM710e is designed for incorporation into closed-loop control systems. Connectivity options include:

- **Digital**
- **Analogue**
- **Industrial Ethernet**
- **Fieldbus**

Using industry-standard Ethernet communication hardware such as hubs, cables, repeaters and routers, installation and integration of the modular CM710e gauging system is straightforward.

For network integration, the Gauge can be configured for the following industrial Ethernet protocols:

- **EtherNet IP**
- **PROFINET**
- **Modbus/TCP**

If Fieldbus connectivity is required, the OWS, HMI and User Port can be supplied with Network Gateways for:

- **PROFIBUS DP**
- **DeviceNet**
- **CANbus Open**

Series 710e Peripheral Devices are available to connect to the gauges via standard Cat5E cable, including:

- **Operator Workstation (OWS)**
- **Human Machine Interface (HMI)**
- **User Port**
- **Switched Network Hub**

CM710e: BENEFITS



- **Lowest Cost of Ownership**
- **Maximum Flexibility**
- **Fastest Return on Investment**
- **Maximum Process Profitability**
- **Best Practice Support**



The OWS provides operator-level interaction with an individual gauge; the HMI provides supervisory access to up to 16 networked CM710e gauges. Both units feature high definition multi-lingual colour touch screen displays. The User Port provides additional analogue outputs and digital I/O for any connected gauge.

For simplicity and convenience, all CM710e system components run on **24V DC**, either from an on-site supply or from an NDC in-line 24V universal power supply.

Long term stability, industry-best performance, low installation costs and no routine maintenance requirements guarantee the **lowest cost of ownership** over the CM710e's many years of service.

Engineered for Real-time Measurement

Easy to install and integrate, the CM710e is the most flexible industrial moisture gauging system available...

WITH A WIDE RANGE OF CONFIGURATION OPTIONS...

A single CM710e Gauge with OWS and/or HMI



A multi-gauge CM710e Gauging System: up to 16 gauges can be networked to a single HMI

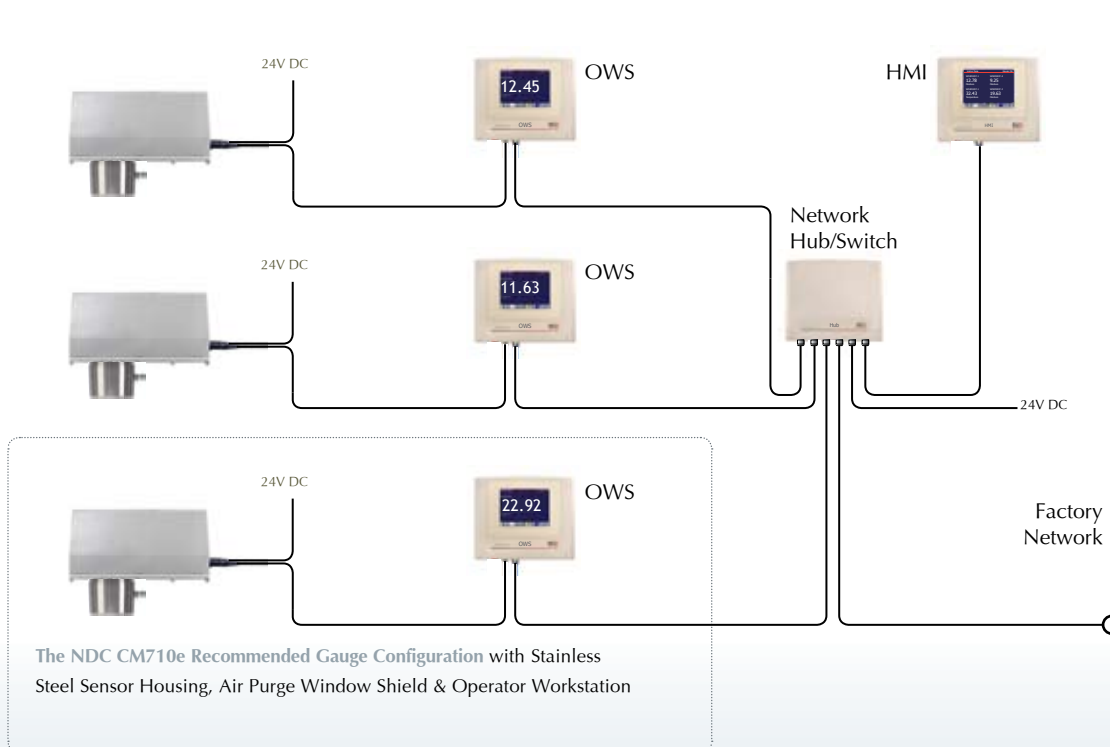

How the CM710e works

Light from a QH lamp is split into sequential pulses of NIR energy at wavelengths which are absorbed by the parameter being measured. Before emitting the light onto the product, the CM710e diverts a portion of the beam onto the secondary detector, to form the reference signal against which the returning diffusely reflected light will be compared. The light leaving the CM710e interacts with the product and any unabsorbed energy is reflected back into the instrument, captured on a special 24 segment mirror and focused onto the primary detector.

The signals on the primary and secondary detectors are then processed via the appropriate measurement algorithm to generate a linear output which responds proportionally to changes in the product moisture. The patented optics reject influences due to changes in ambient lighting, RH and temperature to provide a highly stable measurement, irrespective of product height fluctuation.

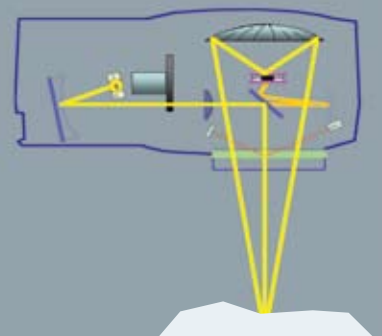

Advanced Applications Engineering

NDC Applications Engineering combines in-depth process understanding with robust Near Infrared (NIR) technology to generate a robust solution to meet your on-line measurement needs...

CM710e INDUSTRIAL MOISTURE MEASUREMENTS	
PRODUCT GROUP	APPLICATION AREAS
Building Products	Cement Meal, Concrete Mix, Gypsum, Roof Tile Chips, Sand
Ceramics	Ball Clay, Refractory Clay, Spray Dried Clay, Kaolin Granules, Tiles
Chemicals	Chemical Powders, Phosphates, Nitrates, Nitrocellulose Chips, Potassium Fluoride, Salt, Sodium Carbonate/Bi-carbonate, Sulphur
Detergents	Carbonates, Zeolites, Phosphates, Detergent Slurry
Minerals and Ores	Alumina, Aluminium Hydroxide, Fly Ash, Bauxite, Bentonite, Calcium Fluoride, Calcium Carbonate, Coke Breeze, Copper Tailings, Copper Ore, Nickel Ore, Dolomite, Ferrite Powder, Furnace Slag, Laponite, Sinter Mix, Titanium Dioxide
Polymer Products	Acrylic Powder, ABS Powder, Nylon Granules, PVC Powder, Rayon Fibre, Neoprene Rope
Wood and Cellulose	Acetate Tow, Pulp Sheet, Paper Fibre Pulp, Paper Mill Sludge, Sawdust, Woodchips, Particle Board, Veneers
Others	Rubber Crumb, Cork Chips, Cotton, Sewage Slurry, Textile Fibres, Wool
For specific ranges and measurement accuracy, please consult the relevant NDC Application Notes	

GaugeToolsXL™ SOFTWARE

The CM710e is delivered with NDC's "SpeedCal" pre-calibration ready for use for the specified measurement(s) and range(s). On installation it is simply adjusted to agree with the local reference method. The **GaugeToolsXL** software provided simplifies this process by enabling comparison of CM710e values (collected on-line using the SAMPLE function on the OWS) with laboratory results. In addition, GaugeToolsXL features these user Tools:

- Gauge Set-up and Calibration
- Product Management (Product Settings)
- Displays of Measurement and other Key Parameters
- Data Logging and Data Trending & Export
- Diagnostic Functions
- Device Set-up
- OPC Server (optional)

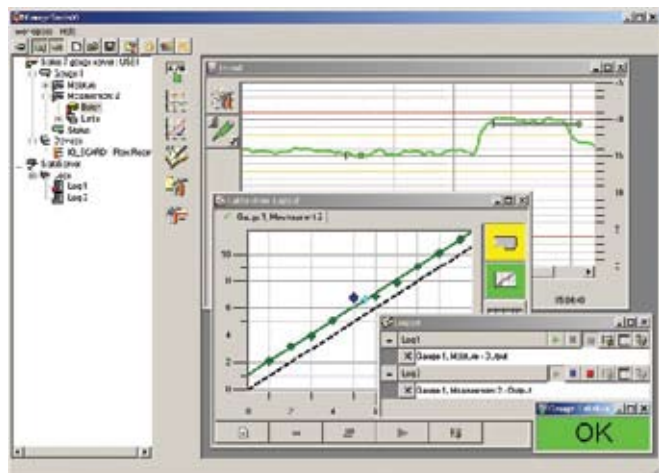

CM710e Installation Guidelines

Installation

The CM710e measures over a 60mm diameter area (optionally 25mm) and should be attached to a sturdy support and suspended over the conveyor or process line at a distance from the mean product height to the CM710e measurement window of 250mm. The gauge tolerates product height fluctuations of $\pm 100\text{mm}$, without affecting the measurement. The Operator Workstation should be installed near the gauge in a position where the display is clearly visible.

Discontinuous Product Flows

Optional "gating" systems are available, with automatic product presence/absence recognition (using optical or ultrasonic sensors) for discontinuous product flows.

Measuring Powders in Gravity-fed or Pneumatic Ducts

Sometimes powders are transported in ducting systems. For these, a PowderVision Powder Sampler is available. The device comprises a tube fitting with window and sample collection cup. The cup fills with product and after the sample has been measured, a jet of air ejects the sample and the cycle recommences. For very abrasive or heavy powders a Heavy-Duty PowderVision is available. See the separate Product Information Sheet for details.

Ambient Conditions

The CM710e's alloy or stainless steel housings are sealed to IP65 standard and can operate in ambient temperatures between 0 and 50°C without cooling. The stainless steel housing is also available in IP67 and ATEX-certified versions. A vortex cooler attachment or insulated air-cooled housing are available for ambient temperatures exceeding 50°C. An optional Air Purge Window Shield connects to a clean air supply to create a positive air pressure in front of the measurement window to prevent contamination. Ambient lighting or relative humidity changes do not affect the CM710e measurement.

The OWS, HMI and all other Devices feature rugged ABS housings, sealed to IP65 and suitable for use in ambient temperatures between 0 and 50°C. The OWS and HMI are also available in stainless steel.

Additional Technical Information Sources

As standard, NDC provides a 10m power cable and 10m network cable to the nearest Device. For additional technical information about alternative cable lengths, and the CM710e generally, please also consult: "CM710e Technical Specifications", "Series 710e Configuration Examples" and also: "Series 710e Configuration and Connectivity Guide" and "Series 710e Gauge Overview".

Support

Please consult your local representative (see website for details) or consult NDC's Customer Care and Applications Technical Support Teams at the numbers and email addresses below.

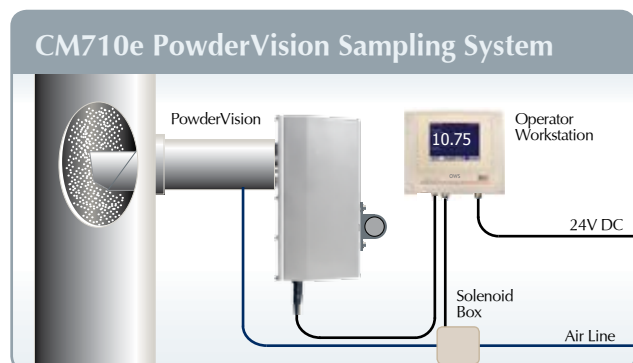
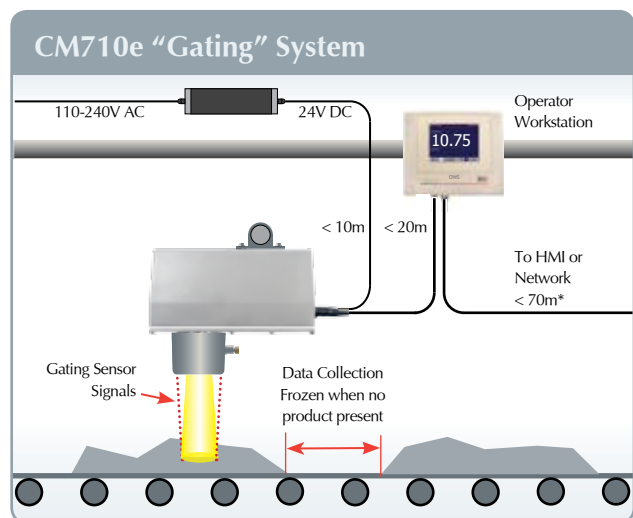
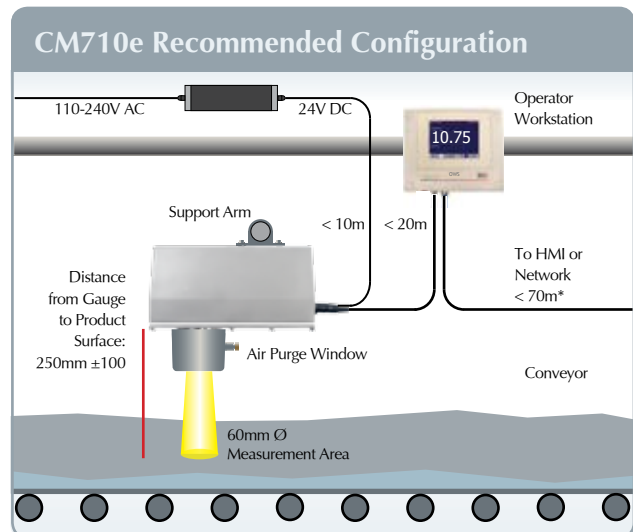

NDC Infrared Engineering is represented in over 60 countries worldwide

a **spectris** company

www.ndcinfrared.com

ISO9001:2000

NDC Infrared Engineering Ltd

Bates Road, Maldon
Essex, CM9 5FA
United Kingdom

Tel: +44 1621 852244

Fax: +44 1621 856180

Email: sales@ndcinfrared.co.uk

NDC Infrared Engineering Inc

5314 North Irwindale Avenue
Irwindale, CA 91706
United States of America

Tel: +1 626 960 3300

Fax: +1 626 939 3870

Email: info@ndcinfrared.com

NDC China

Tel: +86 20 8666 2790

Fax: +86 20 8666 5963

Email: info@ndcinfrared.com.cn

www.ndcinfrared.com/cn

NDC Germany

Tel: +49 1801 977112

Email: info@ndcinfrared.de

NDC France

Tel: N° Azur: 0810 600 400

Email: info@ndcinfrared.fr

NDC Japan

Tel: +81 3 3255 8157

Email: info@ndcinfrared.jp

NDC Brazil

Tel: +55 11 5188 8172

www.ndcinfrared.com.br